

SPARE PARTS MANUAL: CHASSIS

ART.NO.: 3CFF2475M3EN

ENGLISH

FRONT FORK, TRIPLE CLAMP

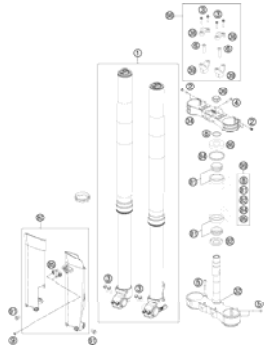

4

FRONT FORK DISASSEMBLED

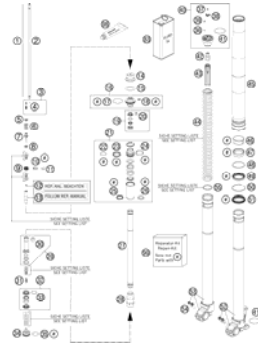

5

HANDLEBAR, CONTROLS

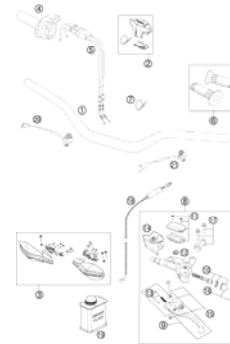

8

FRAME

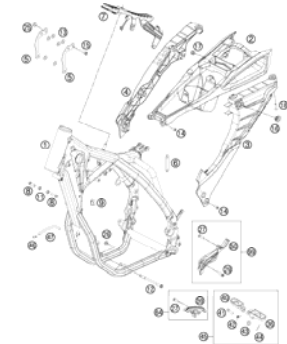

9

ENGINE GUARD

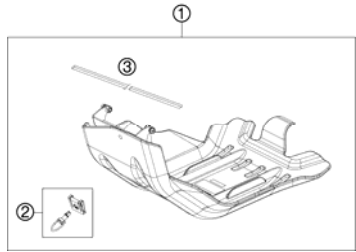

10

SIDE / CENTER STAND

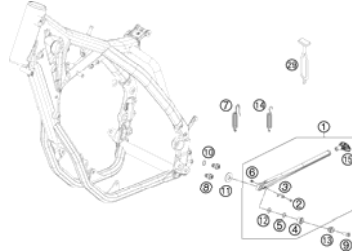

11

SWING ARM

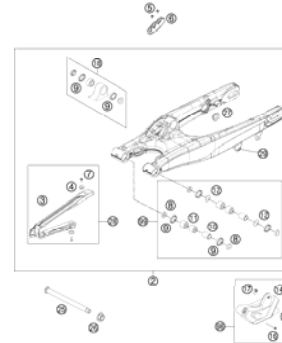

12

SHOCK ABSORBER DISASSEMBLED

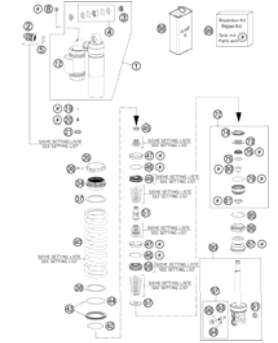

13

SHOCK ABSORBER

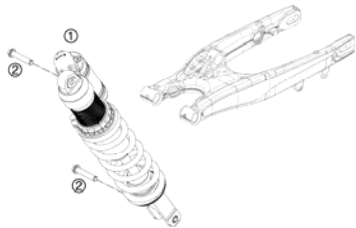

15

EXHAUST SYSTEM

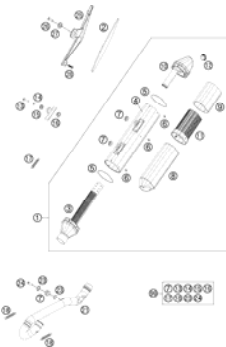

16

AIR FILTER

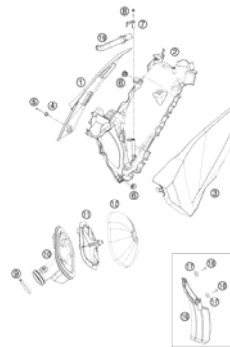



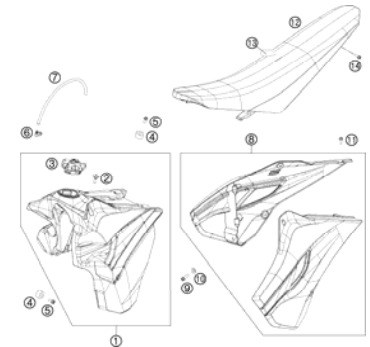

17

TANK, SEAT, COVER

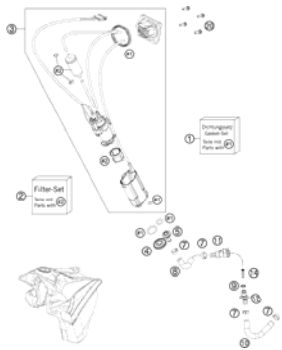
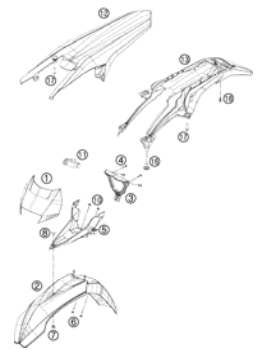

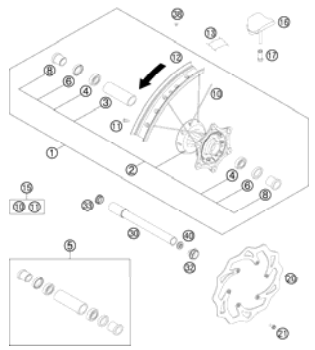
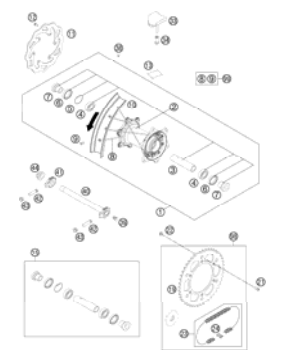
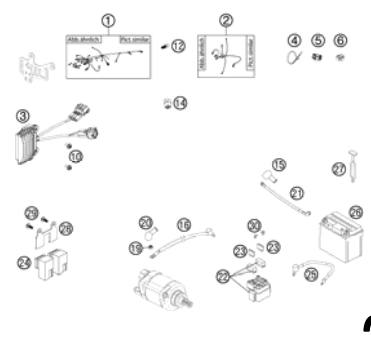
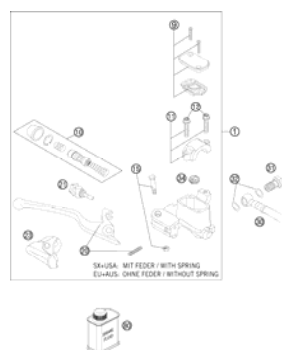
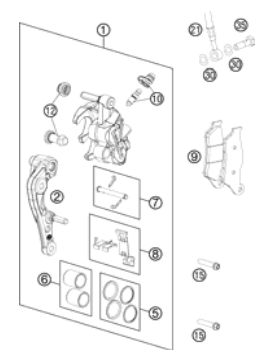
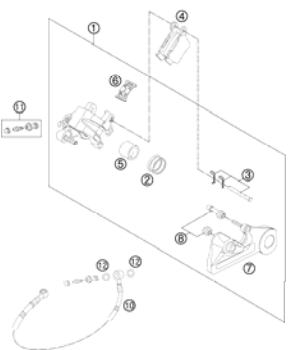
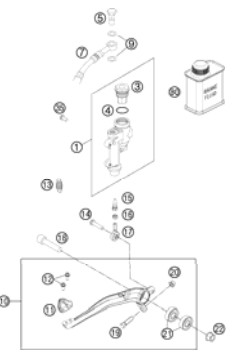
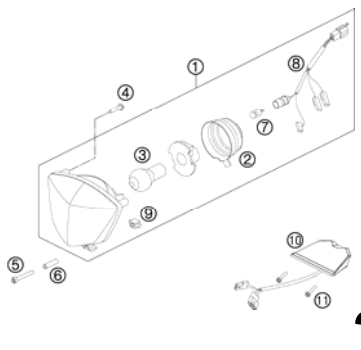
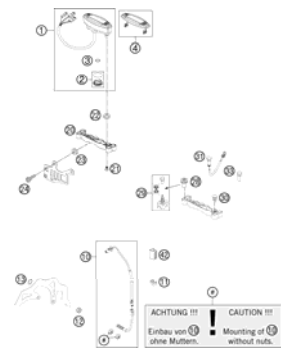
18

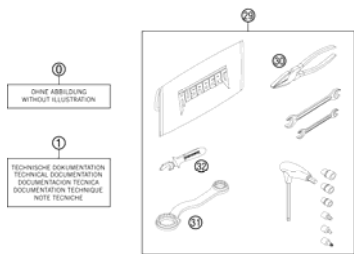
<p>FUEL PUMP</p>  <p>19</p>	<p>MASK, FENDERS</p>  <p>20</p>	<p>DECAL</p>  <p>21</p>	<p>FRONT WHEEL</p>  <p>22</p>
<p>REAR WHEEL</p>  <p>23</p>	<p>WIRING HARNESS</p>  <p>25</p>	<p>HAND BRAKE CYLINDER</p>  <p>26</p>	<p>BRAKE CALIPER FRONT</p>  <p>27</p>
<p>BRAKE CALIPER REAR</p>  <p>28</p>	<p>REAR BRAKE CONTROL</p>  <p>29</p>	<p>LIGHTING SYSTEM</p>  <p>30</p>	<p>INSTRUMENTS / LOCK SYSTEM</p>  <p>31</p>

<p>ACCESSORIES KIT</p>  <p style="text-align: right; font-size: 2em;">32</p>			
	<div style="display: flex; align-items: center;">  <p> All information contained is without obligation. KTM-Sportmotorcycle AG particularly reserves the right to modify any equipment, technical specifications, prices, colors, shapes, materials, services, service work, constructions, equipment and the like so as to adapt them to local conditions or to cancel any of the above items, all without previous announcement and without giving reasons. KTM may stop manufacturing certain models without previous notice. KTM shall not be held liable for any deviations of availability and/or ability to deliver, illustrations, descriptions, printing and/or other errors. The illustrated models partly contain extra equipment, which is not applied to standard models. © by KTM-SPORTMOTORCYCLE AG, Mattighofen AUSTRIA; All rights reserved; Reprint, also in extracts, with written allowance of KTM-SPORTMOTORCYCLE AG, Mattighofen only. </p> </div>		

FRONT FORK, TRIPLE CLAMP

FE 501 USA 2013

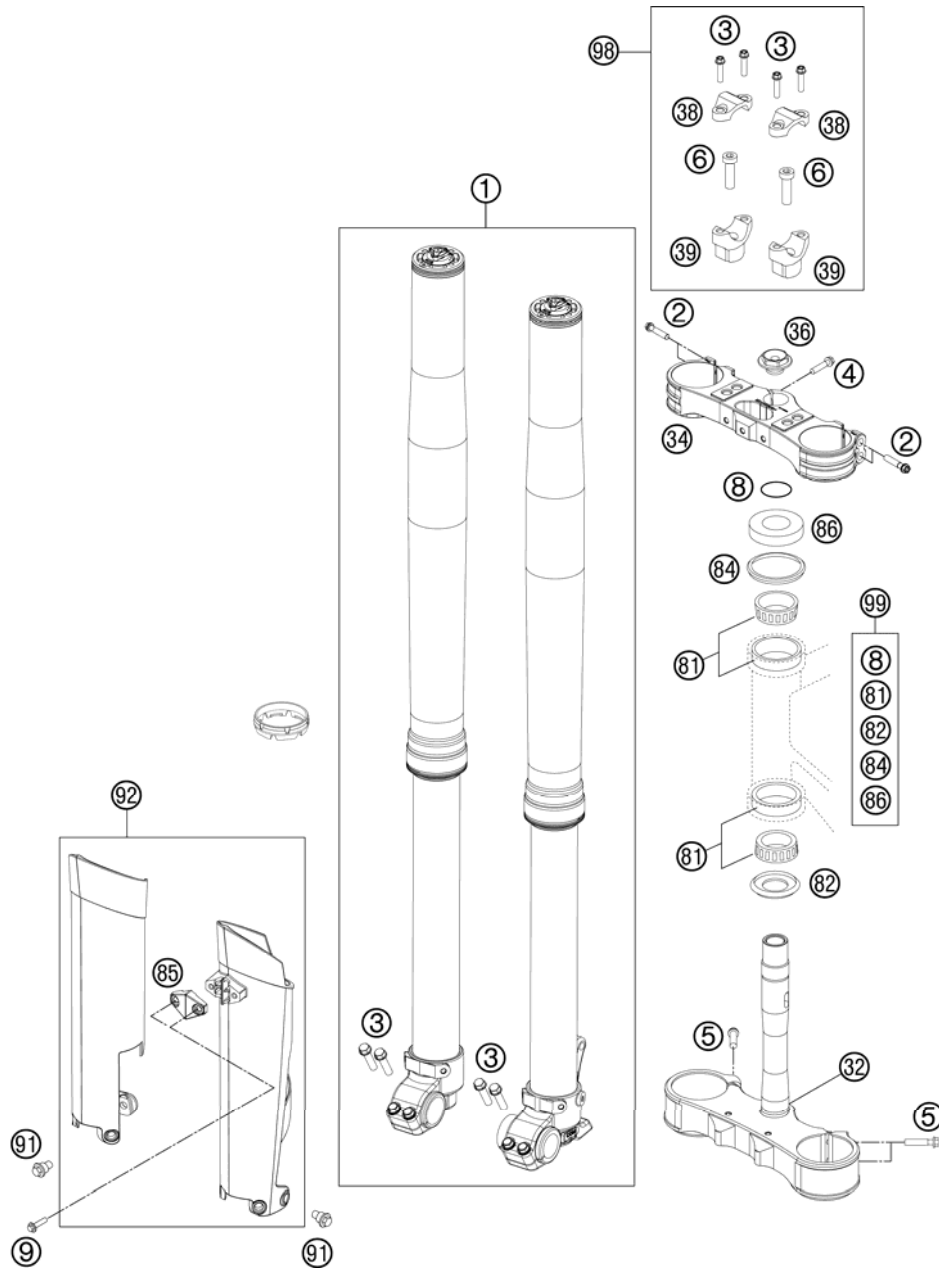

FIG	PART NUMBER	DESCRIPTION	QTY
1	24187M6901	FORK WP 450/500 FE	1
2	0025080406	HH COLLAR SCREW M8X40 TX40	4
3	0025080256	HH COLLAR SCREW M8X25 TX40	8
4	0015080256S	HH COLLAR SCREW M8X25 WS=10 06	1
5	0025080356	HH COLLAR SCREW M8X35 TX40	4
6	0032100356S	AH-COLLAR SCREW M10X35 ISA45	2
8	0770025035	O-RING 25X3,55 NBR70 05	1
9	0017060204	EJOT PT SCREW K60X20 ALU WS=6	2
32	7800103202030	BOT. TRIPLE CLAMP CPL. 20MM	1
34	7720103402030	TOP TRIPLE CLAMP X=20MM BLACK	1
36	54801036000	STEER.HEAD SCREW M20X1,5 WS=27	1
38	77201038000	HANDLEBAR CLAMP 28MM	2
39	59401039032	HANDLEB.SUPP. D=28MM H=32MM 05	x
39	59401039037	HANDLEB.SUPP. D=28MM H=37MM 05	2
39	59401039042	HANDLEB.SUPP. D=28MM H=42MM 05	x
81	54201081100	TAPERED ROLLER BEARING CPL. 06	2
82	54601084100	O-RING SUPPORT W. SEALING LIP	1
84	54601184000	STEERING HEAD GASKET TOP	1
85	7800108500028	CLAMP F. SPEED. CABLE D=6MM 08	1
86	78101086000	STEERING HEAD COVER	1
91	59001092050	SPECIAL SCREW M6X12,5 WS=8	6
92	7800109410028	FORK PROTECT. L/S+R/S WHITE 09	1
98	00050000921	HANDLEBAR SUPPORT KIT D28/H37	x
99	00050000930	STEERING HEAD REP. KIT	x

138130111 / C138130113

* NEW PART

X AS REQUIRED



FRONT FORK DISASSEMBLED

FE 501 USA 2013

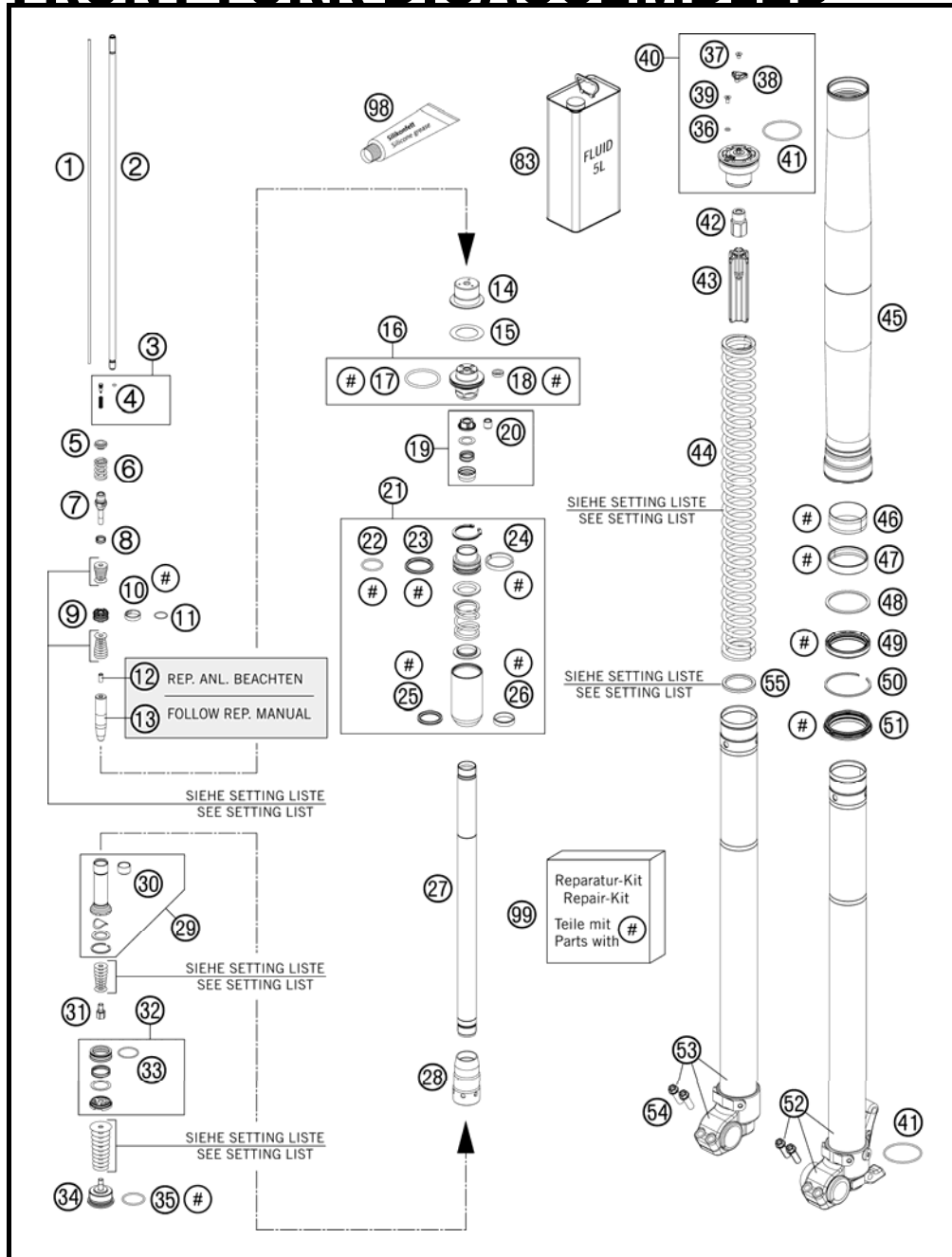

FIG	PART NUMBER	DESCRIPTION	QTY
1	48600996	ADJUSTMENT TUBE L486 OD3	2
2	48601054	PISTON ROD D8 L497	2
3	48600998S	ADJ - NEEDLE CPL.	2
4	48600298	O-RING 2X1,5 NBR	2
5	48601048	GUIDE SHIM REBOUND SPRING	2
6	48601049	REBOUND SPRING L25	2
7	48600986	TAP REBOUND M8	2
8	48600382	SHUTTLE VALVE SPRING C=0,4	2
9	48600985	PISTON REBOUND D20	2
10	48601171	Z-CUT RING D18 PLASTIC	2
11	48601128	O-RING 15X1	2
12	48601033	PUSHER D=5,5	2
13	48600999	NEEDLE D14 WHITE	1
		L/S	
13	48601123	NEEDLE D14 RED	1
		R/S	
14	48601061	SPRING GUIDANCE BELOW	2
15	48601184	SHIM 29X44X0,3	2
16	48601022S	SCREW SLEEVE M23,5 CPL.	2
17	48601130	O-RING 40X3	2
18	48600954	GASKET D8	2
19	48601025S	CHECK VALVE D21 CPL.	2
20	48600953	GUIDING BUSH 8X10X10	2
21	48601021S	PRESSURE TANK L74,5 D36 KPL.	2
22	48601127	O-RING 24x2	2
23	48601111	QUAD RING 29,74X3,53	2
24	48601124	BUSHING DO=36 DI=32 B5	2
25	48601110	QUAD RING 24,99X3,53	2
26	48601109	SLIDE BEARING	2
27	48601031	TUBE D20 L403	2
28	48601019	SCREW SLEEVE D20/28	2
29	48601030S	STOP L75	2
30	48601180	BUSHING	2
31	48601083	NUT M6X0,5	2

138120130 / C138130130

* NEW PART

X AS REQUIRED



FRONT FORK DISASSEMBLED

FE 501 USA 2013

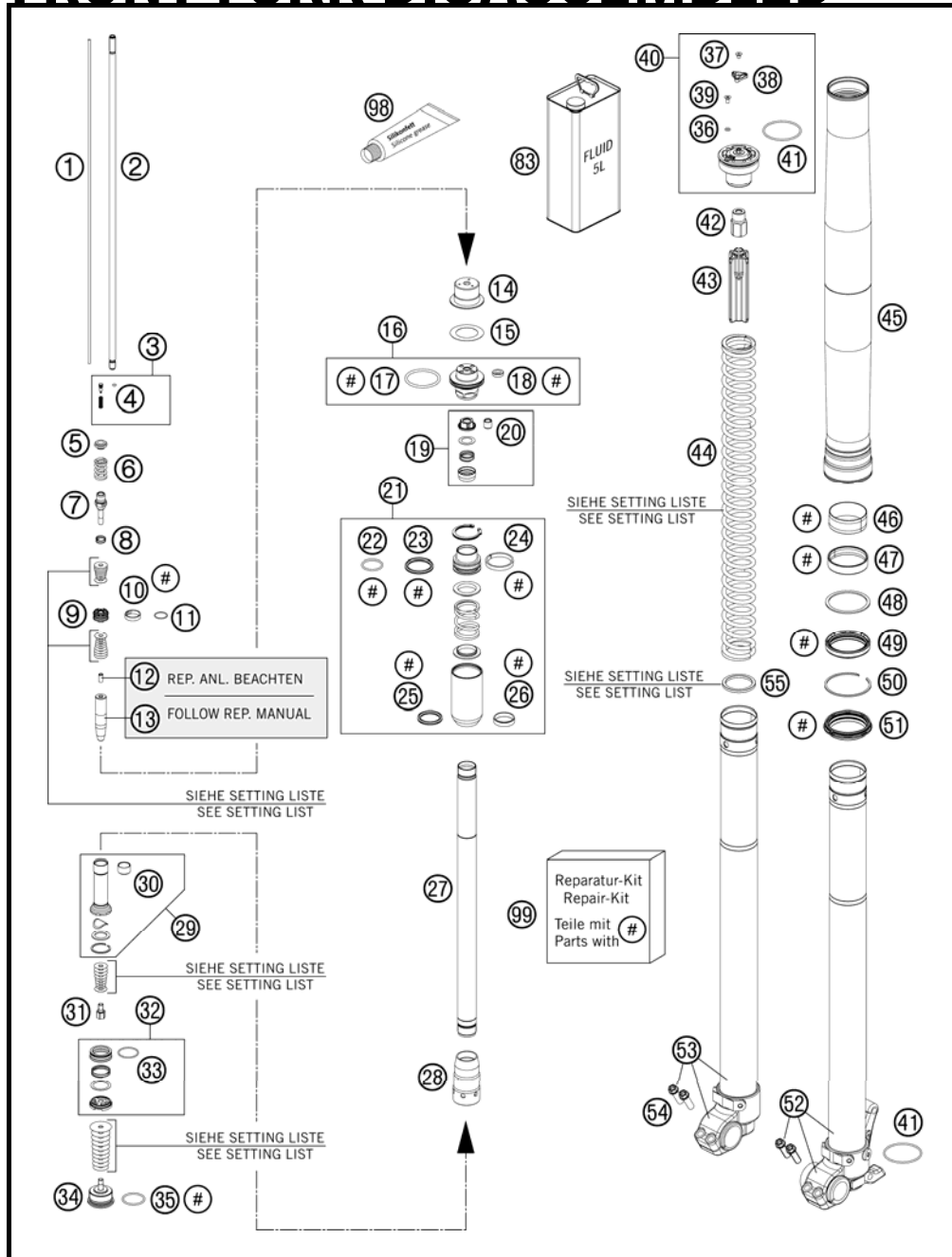

FIG	PART NUMBER	DESCRIPTION	QTY
32	48600984S	PISTON COMPRESSION D=28 CPL.	2
33	48601133	O-RING 24X1,5	2
34	48601020	SCREW CAP M30	2
35	48601132	O-RING 26X2	2
36	50180222	O-RING NBR 4X1,5	2
37	48600527	AH SCREW M4X6	2
38	48601117	DIAL COMPRESSION WHITE L/S, COMPRESSION	1
38	48601118	DIAL REBOUND RED R/S, REBOUND	1
39	48600481	VENT SCREW M4X8	2
40	48601050S	SCREW CAP M51X1,5 REB. KPL. R/S, REBOUND, RED	1
40	48601116S	SCREW CAP M51X1,5 COMP. KPL L/S, COMPRESSION, WHITE	1
41	48600048	O-RING NBR 46 X 2	4
42	48601034	COUNTERNUT M8	2
43	48601035	SPRING GUIDANCE D23	2
44	91410082S	SPRING D43,8 L465 3,8N/MM SET	x
44	91410083S	SPRING D43,8 L465 4,0N/MM SET	x
44	91410084S	SPRING D43,8 L465 4,2N/MM SET	x
44	91410085S	SPRING D43,8 L465 4,4N/MM SET	x
44	91410086S	SPRING D43,8 L465 4,6N/MM SET	x
44	91410092S	SPRING D43,8 L465 4,8N/MM SET	x
45	48600736	OUTER TUBE L577 D54/60MM 2L	2
46	48601008	GUIDING BUSH 47X49X20 R11	2
47	48601009	GUIDING BUSH 48X52X12 R11	2
48	48600013	SUPPORT RING 50 X 57,6 X 1,5	2
49	48601179	OIL SEALRING D48X57,9X11,4 RED	2
50	48600070	LOCK WASHER SB58	2
51	48601178	DUST SEAL DL48X58,4X5,7 RED	2
52	48601028S1	AXLE CLAMP L/S WITH INNER TUBE	1
53	48601029S1	AXLE CLAMP R/S WITH INNER TUBE	1
54	0025080256	HH COLLAR SCREW M8X25 TX40	4
55	48600458	SPACER 43X35X1,5	x

138120130 / C138130130

* NEW PART

X AS REQUIRED



FRONT FORK DISASSEMBLED

FE 501 USA 2013

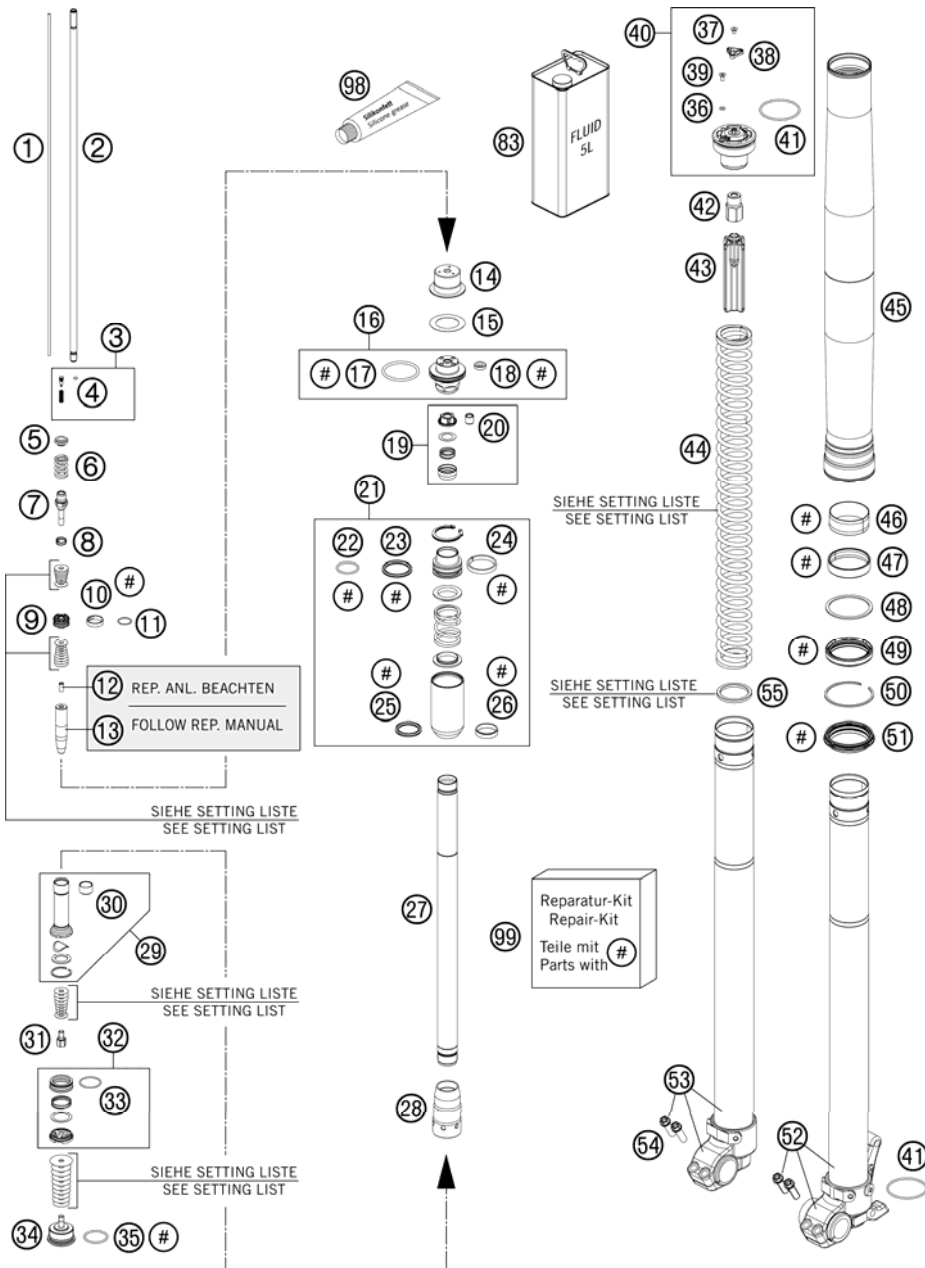

FIG	PART NUMBER	DESCRIPTION	QTY
55	48600456	SPACER 43X35X2,5	X
55	48600457	SPACER 43X35X5	X
83	48601166S1	FORK OIL SAE4 5L	X
98	T511	SILICONE GREASE F. DUST STRI	X
99	R24001	REPAIR - KIT	1

138120130 / C138130130

* NEW PART

X AS REQUIRED



HANDLEBAR, CONTROLS

FE 501 USA 2013

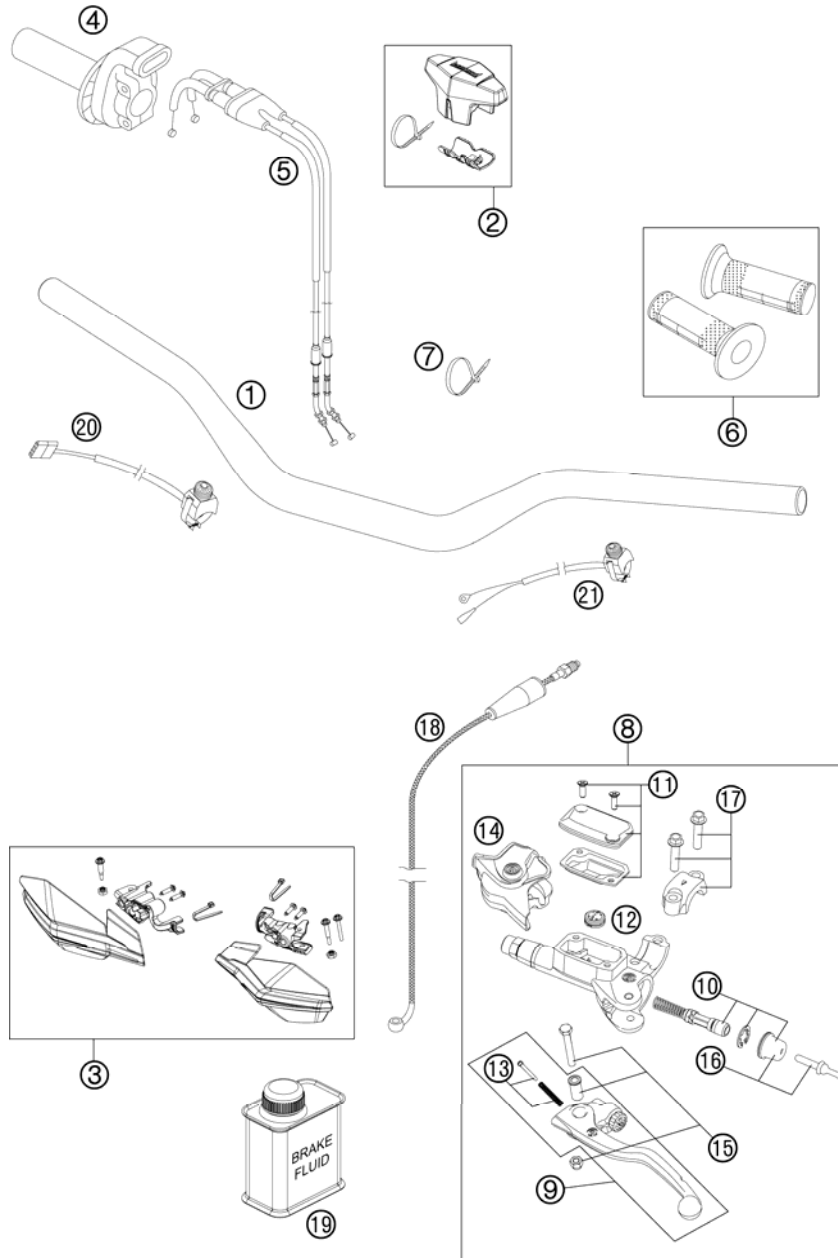

FIG	PART NUMBER	DESCRIPTION	QTY
1	7800200100017	HANDLEBAR D=28MM	1
2	81202002144	BAR PAD CPL.	1
3	7810297910028	HANDGUARD MX CPL. WHITE	1
4	78102010000	THROTTLE GRIP CPL.	1
5	78102091000	THROTTLE CABLE 4T. 13	1
6	81202021000	GRIP SET	1
7	44011076140	CABLE TIE 140/2,5MM BLACK	x
7	44011076200	CABLE TIE 200/3,6MM BLACK	x
8	54802030044	MASTER CYLINDER CPL. 06	1
9	54802031000	CLUTCH LEVER CPL. BREMBO 06	1
10	54802032000	REP. KIT PISTON 06	1
11	54802003000	COVER HYD. CLUTCH CPL.	1
12	54802051000	VALVE	1
13	54802052000	BOLT KPL.	1
14	54802037000	PROTECTION CAP 06	1
15	54802038100	LEVER SCREW CPL. 06	1
16	54802046000	PUSH ROD CPL.	1
17	54802005100	CLAMP CPL. 06	1
18	54832063000	CLUTCH PIPE 06	1
19	00062030000	BRAKE FLUID DOT5.1 0,25L	1
20	78111074000	STARTER BUTTON GREY 13	1
21	50311089200	SHORT CIRCUIT BUTTON 02	1

138130215 / C138130215

* NEW PART

X AS REQUIRED



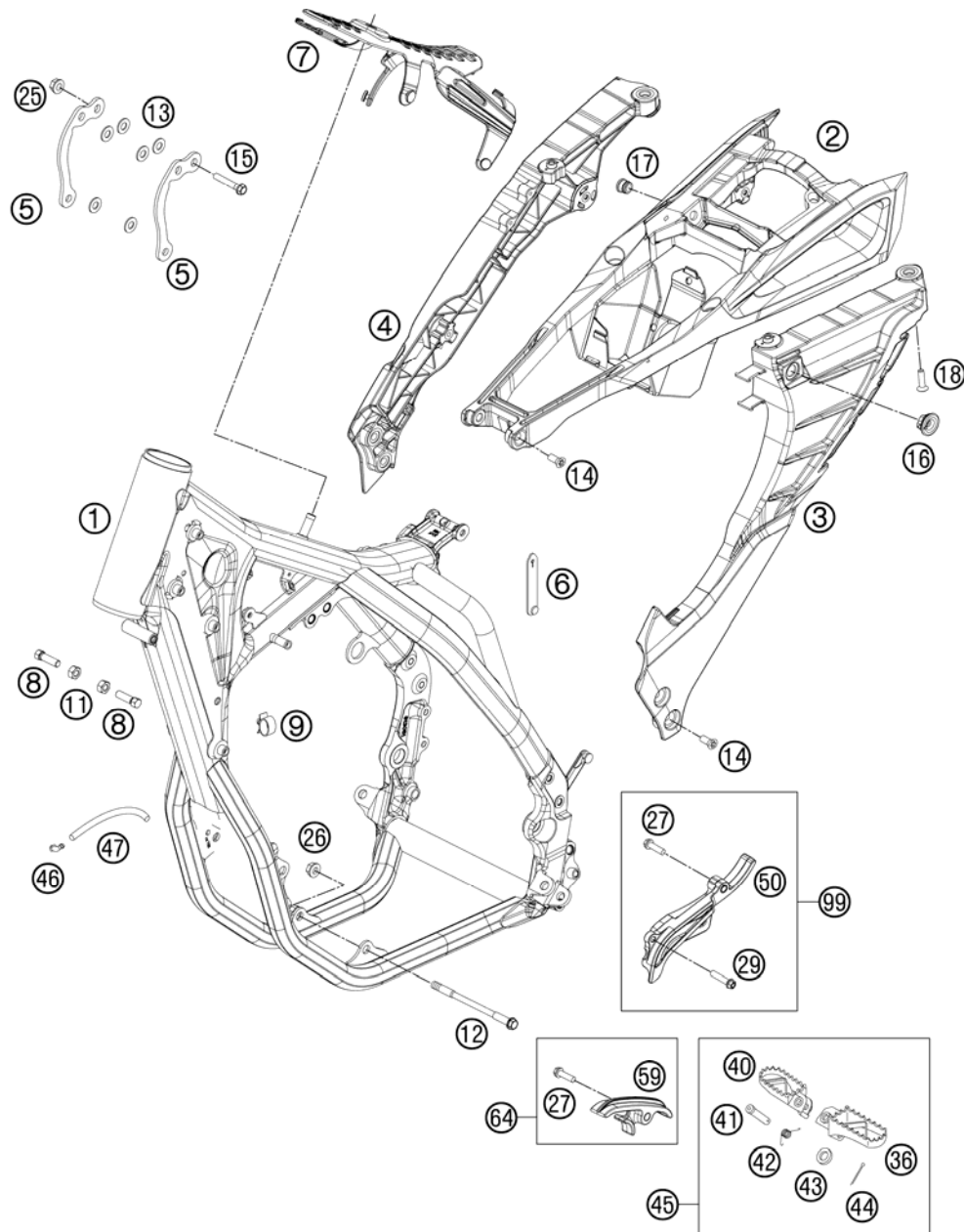

FIG	PART NUMBER	DESCRIPTION	QTY
1	8130320100056	RAHMEN "H781M2"	1
2	81303002010B0	SUB FRAME TOP PART CPL.	1
3	81303002020B0	SUB FRAME L/S CPL.	1
4	81303002030B0	SUB FRAME R/S CPL.	1
5	78703013000	REINFORCING B. 500 XC-W 2012	2
6	60011093075	RUBBER CABLE TIE 75MM 03	1
7	77207012000	TANK REST RUBBER	1
8	59001037000	SPECIAL SCREW M8X26 WS=10	2
9	58111076000	CABLE SUPPORT KHS NR.150-47610	1
11	0934080003	HEXAGON NUT DIN0934-M 8	2
12	59003013000	ENGINEBRAC.SCREW M10X123 WS=13	2
13	77003013050	WASHER 8,5X18X1 INOX	6
14	0019080206S	FLAT HEAD SCREW M. ISA45 M8X20	4
15	56530079000	HH COLLAR SCREW M 8X44 WS13	3
16	47106003160	QUICK CONNECTOR CLUTCH	1
17	81303002011	SPACER BUSHING 12X9X6,2	2
18	0019080306S	COUNTER-SUNK SCREW ISA45 M8X30	4
25	54310086200	SELF LOCKING NUT M8 10.9	3
26	54310086100	SELF LOCKING NUT M10 CU WS=14	2
27	0025080306	HH COLLAR SCREW M8X30 TX40	2
29	0025060306	HH COLLAR SCREW M6X30 TX30	1
36	78003040050	FOOTREST L/S 08	1
40	78003041050	FOOTREST R/S 08	1
41	54803044000	BOLT FOR FOOT PED 03	2
42	54603041000	FOOTREST SPRING L/S & R/S	2
43	0125100003	WASHER DIN0125-A10,5	2
44	0094032253	PIN DIN0094-3,2X25 STEEL	2
45	78003040033	FOOTREST L/S + R/S CPL. 09	1
46	50303089000	ANGLE PIECE '97	2
47	55007016001	PVC-HOSE 7X10 PER METER	x
50	78103096000	CHAIN GUARD 450/500 EXC 12	1
59	77203053000	CHAIN SLIDING PIECE BELOW	1
64	77203053010	CHAIN SLIDING KIT BELOW CPL.11	1
99	78103096010	SPROCKET COVER KIT	x

138130319 / C138130319

* NEW PART

X AS REQUIRED

FIG	PART NUMBER	DESCRIPTION	QTY
1	78103190100	SKID PLATE PLASTIC CPL.	1
2	59003090350	QUICK RELEASE 03	1
3	78103190030	SHIMSTRIPE 1000X11X3	1

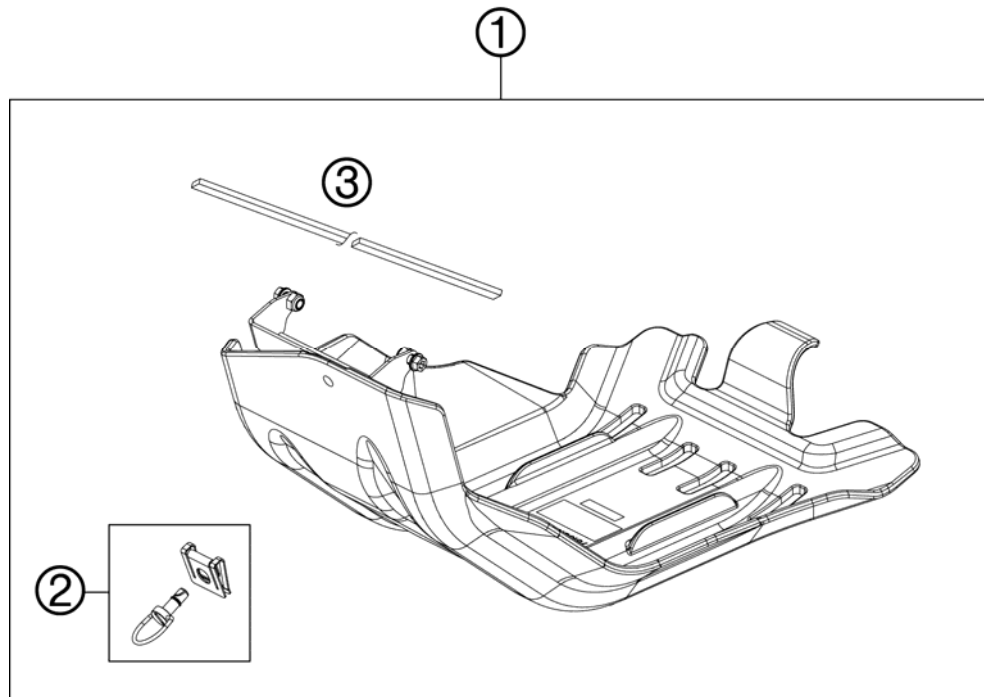

138130331 / C138130334

* NEW PART

X AS REQUIRED

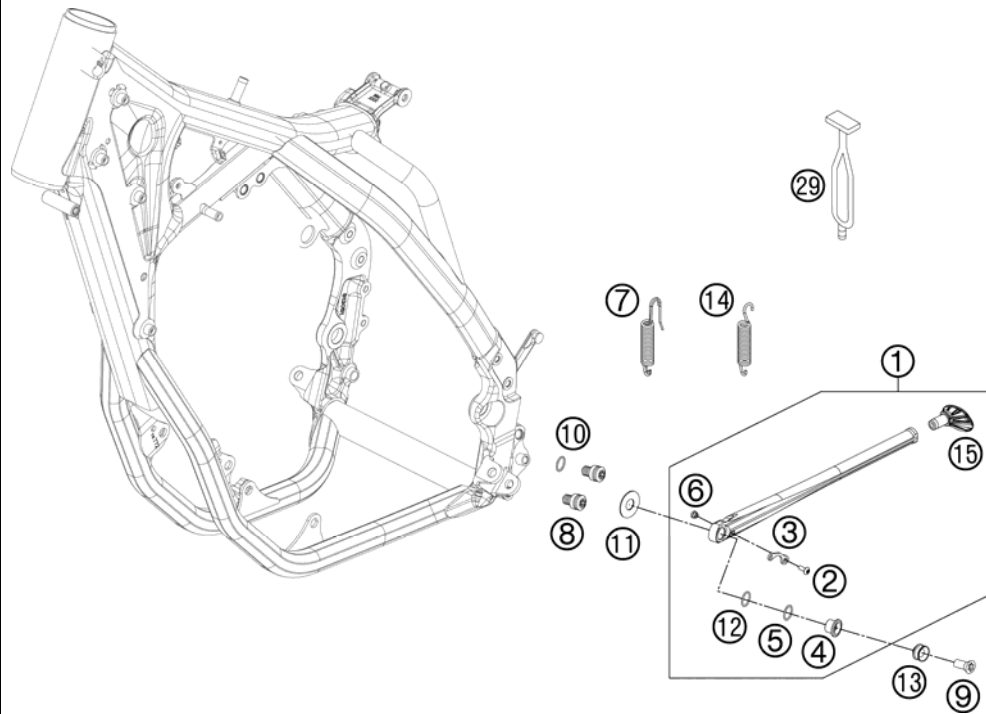

FIG	PART NUMBER	DESCRIPTION	QTY
1	78003023044	SIDE STAND CPL. 08	1
2	58605083014	SCREW M5X14 TORX 25 07	1
3	78003023090	SPRING BRACKET F. SIDE ST. 08	1
4	78003023080	SIDE STAND BUSHING EXC USA 08	1
5	0770180020	O-RING 18,00X2,00 NBR 70	1
6	78003023070	SPACER BUSH. SPRING BRACKET	1
7	81203024000	SIDE STAND SPRING EYE MOVEABLE ONLY FOR EU/AUS	1
8	78003023182	SIDE STAND STOP SCREW M10X12	2
9	0019080206S	FLAT HEAD SCREW M. ISA45 M8X20	1
9	0019080266S	COUNTER-SUNK SCREW ISA45 M8X26 ONLY FOR 78003023081	1
10	0770120020	O-RING 12,00X2,00 NBR 70	1
11	78003023083	WASHER F. SIDE STAND 12,2X29,5	1
12	0770125015	O-RING 12,5X1,5 NBR	1
13	78003023081	SIDE STAND BUSHING EXC-EU 08	1
14	78003024100	SIDE STAND SPRING 08 ONLY FOR USA	1
15	78003023155	STAND BASE	1
29	50303018000	RUBBER L=145MM	1

138130361 / C138130361

* NEW PART

X AS REQUIRED



SWING ARM

FE 501 USA 2013

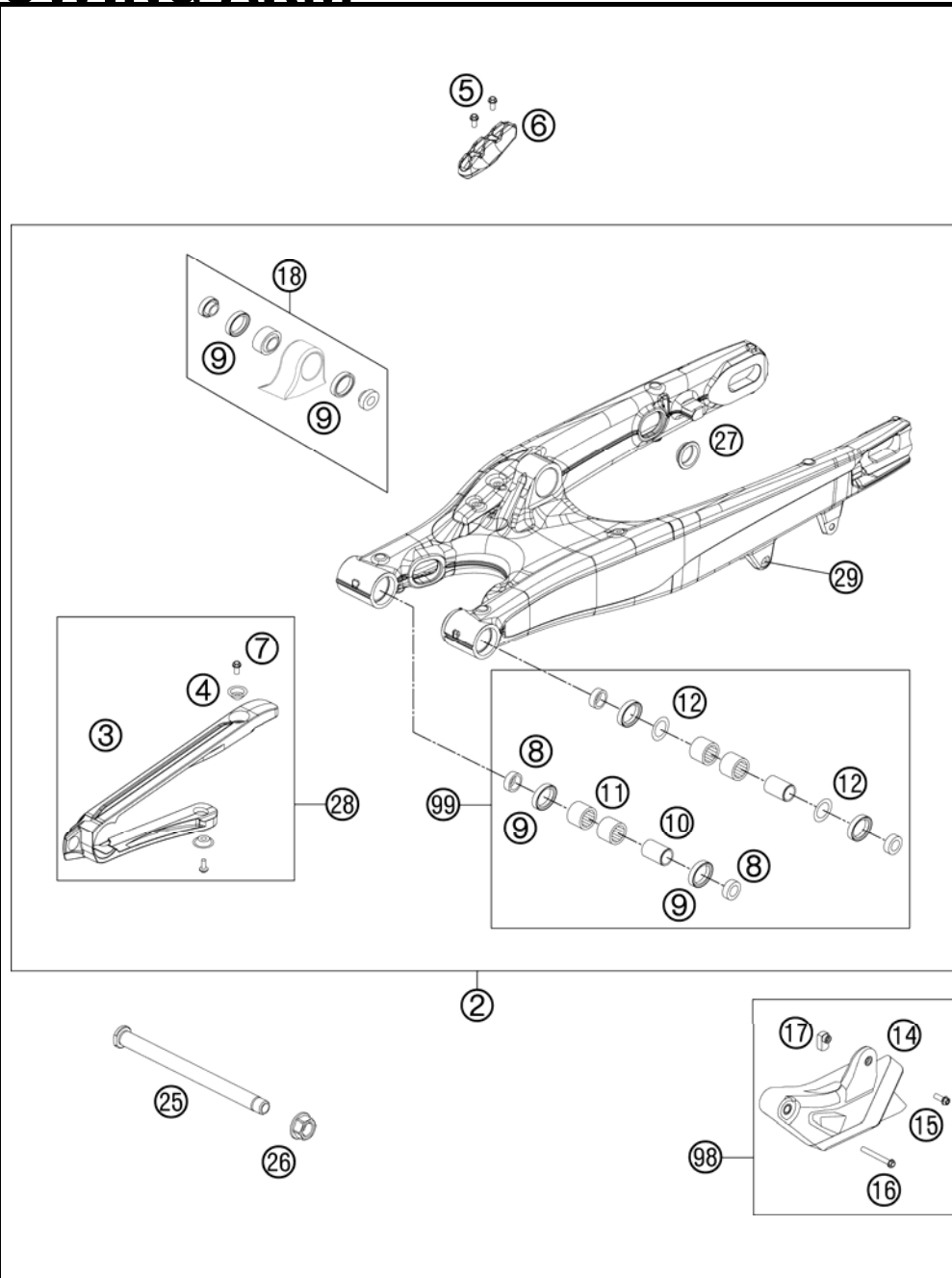

FIG	PART NUMBER	DESCRIPTION	QTY
2	78104030144	SWINGARM PDS XC-W 2012	1
3	51504066000	CHAIN SLID.GUARD PDS	1
4	77304066050	BUSHING F. CHAIN SLIDING PR.07	2
5	0009050106	EJOT SPIRAL SCREW SF M5X10-K	2
6	77313047000	BRAKE HOSE GUIDE LOWER 07	1
7	59009062013	SPECIAL SCREW M6X13 WS=8 10.9	2
8	54804034000	BUCKET F. SHAFT SEAL RING 03	4
9	0760253270	SHAFT SEAL RING 25X32X7	6
10	59404032000	BEARING SLEEVE 17X22X38,7 03	2
11	59004031200	NEEDLE BUSH HK2212V	4
12	54603036000	STOP DISK 22,2X31,7X1	2
14	78004070100	CHAIN GUIDE CPL.	1
15	59009062019	SPECIAL SCREW M6X19 WS=8 10.9	1
16	0025060456	HH COLLAR SCREW M6X45 TX30	1
17	77304070030	INSERTION NUT F. CHAIN GUIDE	1
18	50304090144	PIVOT BEARING+BUSH. PDS '11	1
25	77304037000	SWINGARM BOLT M16X1,5 07	1
26	54804038000	SELF LOCK.NUT M16X1,5 WS=19 03	1
27	77204041000	CLOSING COVER	4
28	51504066044	CHAIN SLIDING GUARD KIT 11-12	x
29	54603055051	PRESS IN NUT M6 STEEL ZINC	1
98	77304070310	CHAIN GUIDE KIT REAR 08-12	1
99	59404230110	SWINGARM-REPAIR KIT 05-12	x

125480490 / C127810490

* NEW PART

X AS REQUIRED



SHOCK ABSORBER DISASSEMBLED

FE 501 USA 2013

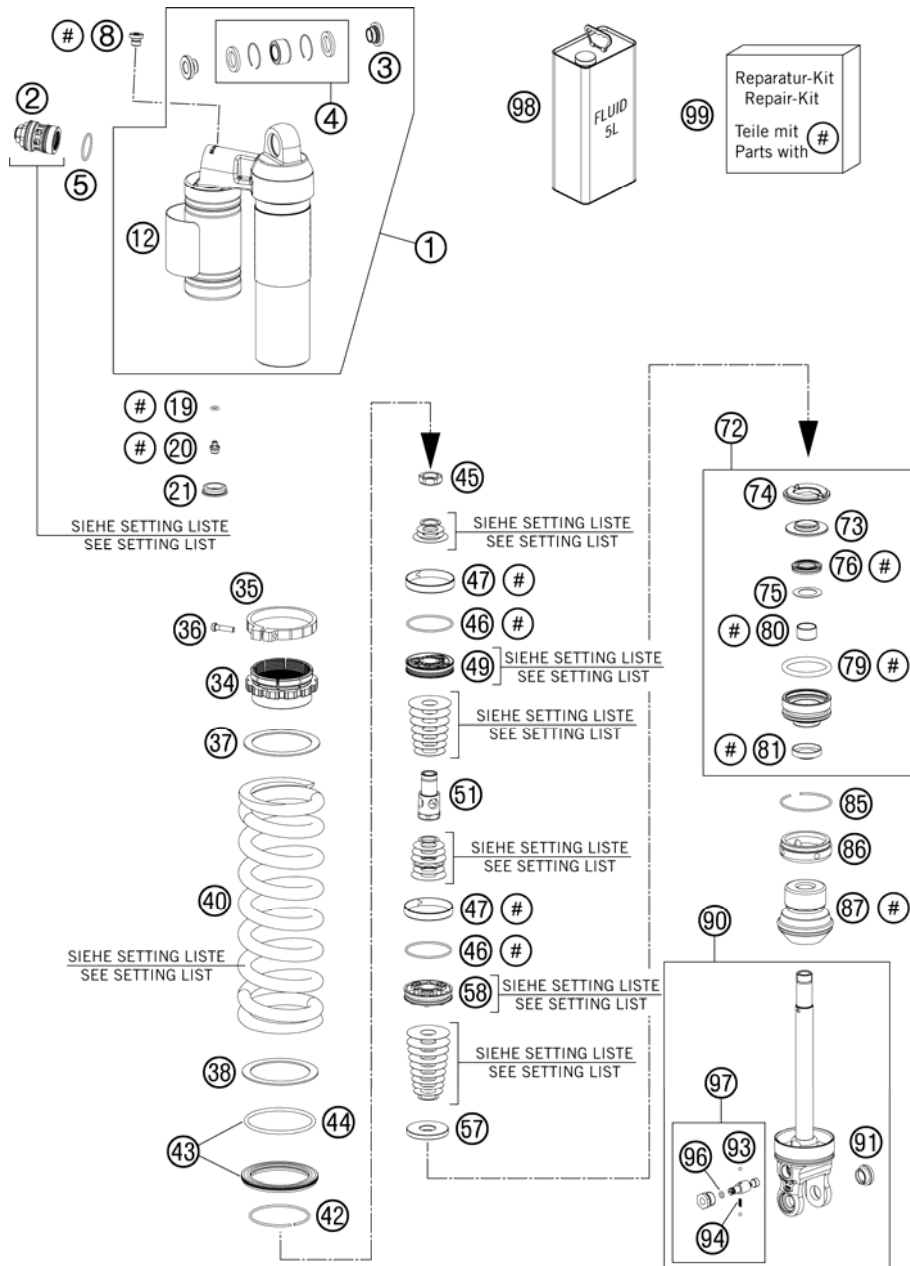

FIG	PART NUMBER	DESCRIPTION	QTY
1	50180833SA2	MONOSHOCK UPPER PART CPL.	1
2	50180213S10	DCC-COMPR.DAMP.CONTROL CPL. 07	1
3	46180007	ADAPTOR BUSH KGW 12X24	2
4	R12012	REP. KIT BEAR./SEAL UP. 07	1
5	50180217	O-RING 27X1,5 VITON	1
8	50180095	BLEED PLUG R 1/8	1
12	52000085	WP CAUTION (PDS KTM)	1
19	46810893	O-RING NBR 5,28X1,78	1
20	36120151	SCREW PLUG M5X6	1
21	46811208	RUBBER CAP "DO NOT OPEN"	1
34	50180938	ADJUSTING NUT PLASTIC	1
35	50180937	TENSIONING RING D64 H10	1
36	14460042	%ALLENHEAD SCREW M5 L=20 STAIN	1
37	50180965	SPACER RING SPRING 61,3X78X3	1
38	50180114	SPACER RING FOR SPRING	1
40	91210077S	SPRING 250 66 N/MM YELLOW	x
40	91210078S	SPRING 250 69 N/MM YELLOW	x
40	91210079S	SPRING 250 72N/MM(64/62)YELLOW	x
40	91210080S	SPRING 250 76 N/MM YELLOW	x
40	91210094S	SPRING 250 63 N/MM YELLOW	x
42	50180273	CIRCLIP 58,2X2	1
43	50180463S	SPRING RET. D=80 W. O-RING 05	1
44	50180352	O-RING VITON 66,27X3,53	1
45	50180627	PISTON ROD NUT M20X1	1
46	50180099	O-RING VITON 44,17X1,78	2
47	50180135	PISTON RING 50-8	2
49	50180675	PISTON D=20	1
51	50180973	SUPPORT D20 M20X1 L51,3 PDS	1
57	50180970	REBOUND DISC D43	1
58	50180197	PISTON 6+6X7/4,5	1
72	50180603S	ADAPTOR CPL. D=50 H=28 08	1
73	50180113	STEEL DISC 18X,5X43,7X6	1
74	50180107	REBOUND RUBBER	1
75	50180604	SHIM D29,75 X D19 X T0,4 08	1
76	50180605S	SEAL D18X30X5 08	1

125480430 / C138120430

* NEW PART

X AS REQUIRED



SHOCK ABSORBER DISASSEMBLED

FE 501 USA 2013

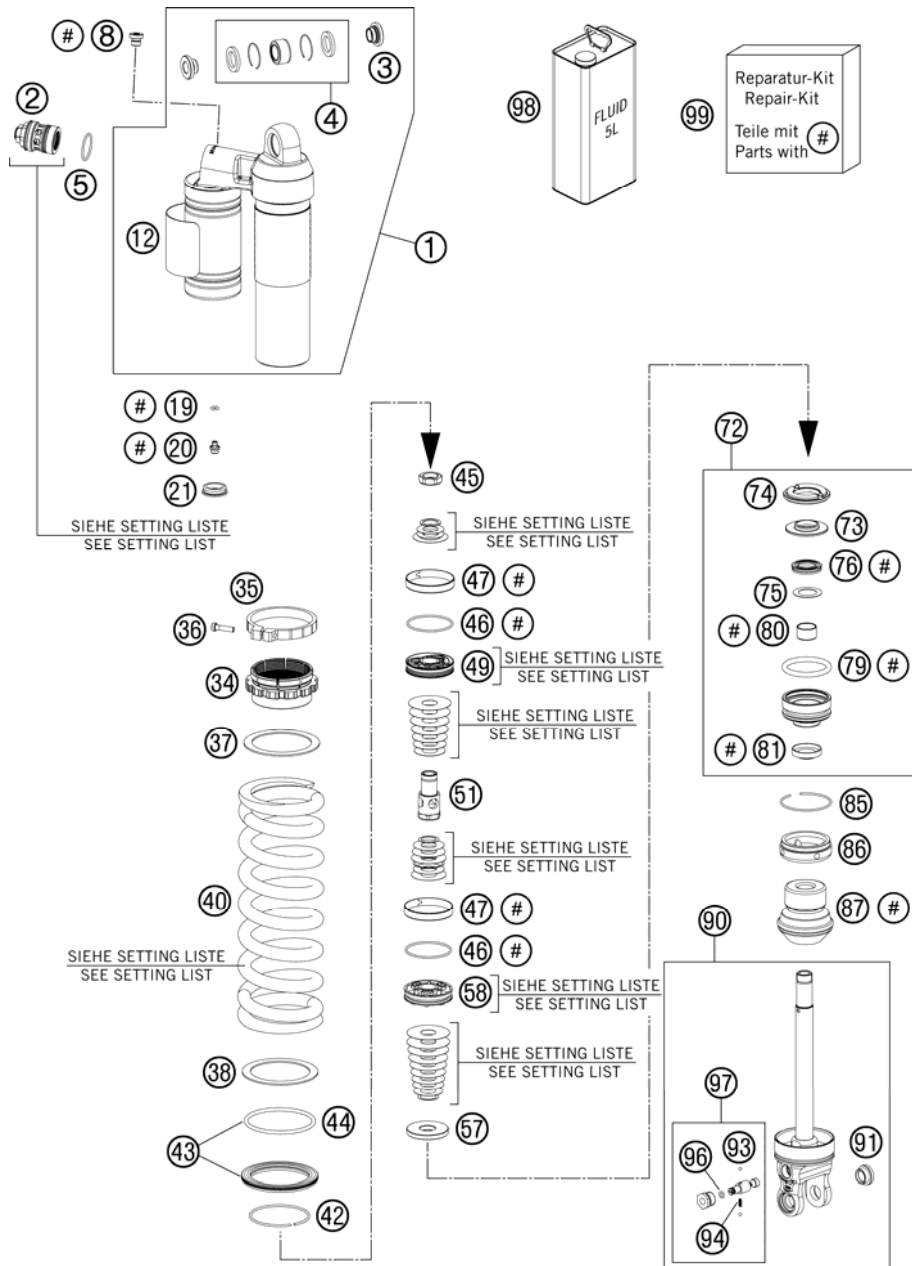

FIG	PART NUMBER	DESCRIPTION	QTY
79	50180103	O-RING 41X5	1
80	46180119	DU-BUSH 18X20X12	1
81	50180606	DUST SEAL 1828 08	1
85	50180126	CIRCLIP 53X1,75	1
86	50180626	RESERVOIR CAP D=50 H=10 09	1
87	50180600	BUMP RUBBER D58 D17 H59 2008	1
90	50180512SA4	SHOCK ABS. LOWER PART CPL. 12	1
91	50180105	THREADED BUSH M12 PDS	1
93	40540603	STEEL BALL D=3MM	2
94	48600028	SPRING D=2,9 L=7,9	1
96	50180222	O-RING NBR 4X1,5	1
97	50180434S	ADJUSTING SCREW REBOUND TRAVEL	1
98	50180751S1	SHOCK ABSORBER FLUID 5 LT	1
99	R12015	REPAIR KIT 5018 PDS 08	1

125480430 / C138120430

* NEW PART

X AS REQUIRED



SHOCK ABSORBER

FE 501 USA 2013

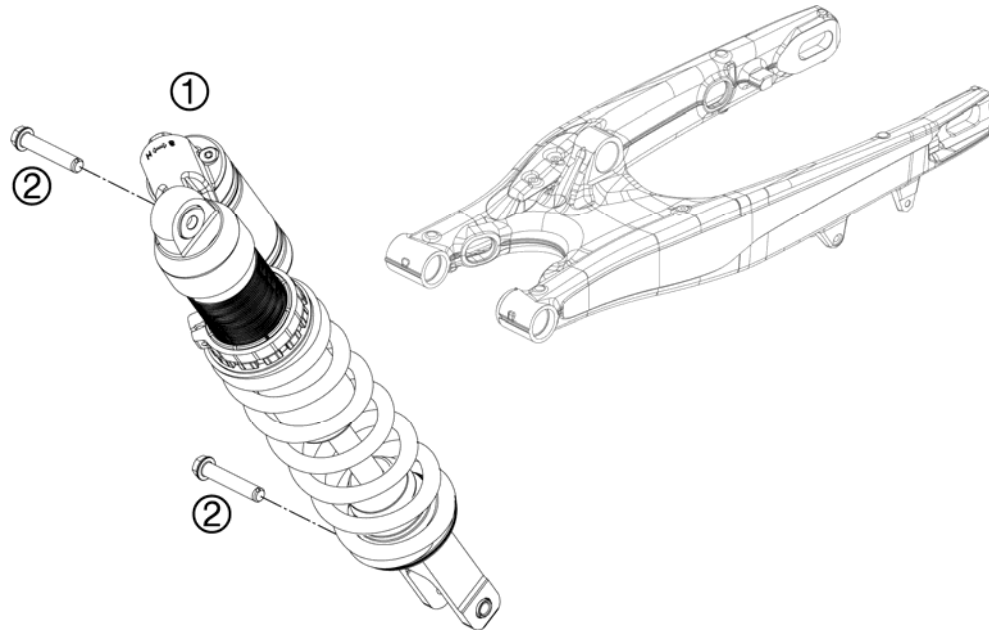

FIG	PART NUMBER	DESCRIPTION	QTY
1	12457M6901	MONOSHOCK 450/500 FE	1
2	0025120506S	HH COLLAR SCREW M12X50 TX45	2

127750410 / C138130413

* NEW PART

X AS REQUIRED



EXHAUST SYSTEM

FE 501 USA 2013

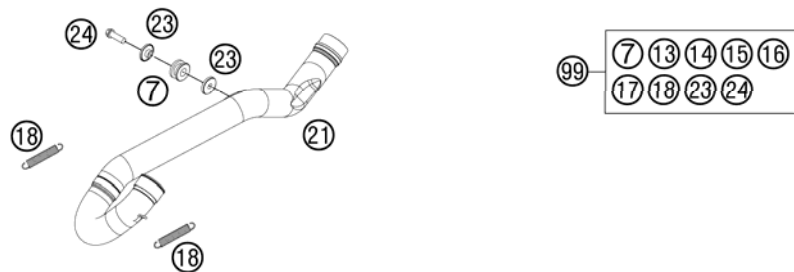
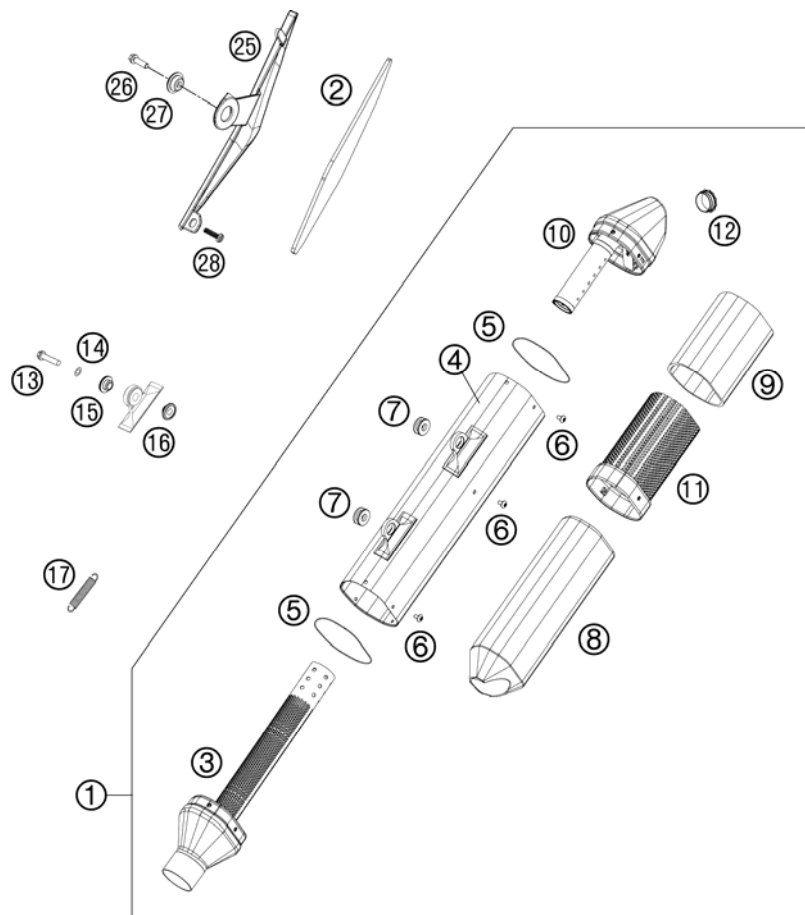

FIG	PART NUMBER	DESCRIPTION	QTY
1	81305082000	ENDDÄMPFER FE USA	1
2	81305011050	THERMAL PROTECTION FOIL	1
3	78105081050	CONNECTING CAP	1
4	81305082080	ENDDÄMPFERHÜLLE FE USA	1
5	0770740015	O-RING 74,00X1,50 FKM 75SH	2
6	78105081010	SCREW TORX M5X10	12
7	77205068000	DAMP. COMPON. BLACK	3
8	78105078400	ROCKWOOL PREFOMED	1
9	78105078070	STUFFING YARN REAR	1
10	78105082060	SILENCER CAP EXC USA	1
11	78105081040	INSERT SILENCER	1
12	77005081055	SIL. ELEMENT EXC-F 07	1
13	0025060306	HH COLLAR SCREW M6X30 TX30	2
14	0137060003	SPRING WASHER DIN0137-B 6	2
15	81305069000	BUSHING 7,5X12X20	2
16	77205169000	BUSHING 7.5x12x28x8.3 11	2
17	50305116000	TEN.SPRING L=75MM EY.MOVEABLE	1
18	50305016000	TEN.SPRING L=62MM EY.MOVEABLE	2
21	78705007000	EXH. PIPE EXC WITHOUT LAMBDA	1
23	59405069000	BUSHING FOR EXHAUST SUPPORT 03	2
24	0025080206	HH COLLAR SCREW M8X20 TX40	1
25	81305011000B0	HEAT SHIELD GREY	1
26	0025060206	HH COLLAR SCREW M6X20 TX30	1
27	77308013010	COLLAR BUSH. F.REAR FENDER 07	1
28	0081050121	SCREW FOR PLASTIC K50X12 T20	1
99	00050000817	EXHAUST PARTS KIT FE 13	x

138130519 / C138130520

* NEW PART

X AS REQUIRED



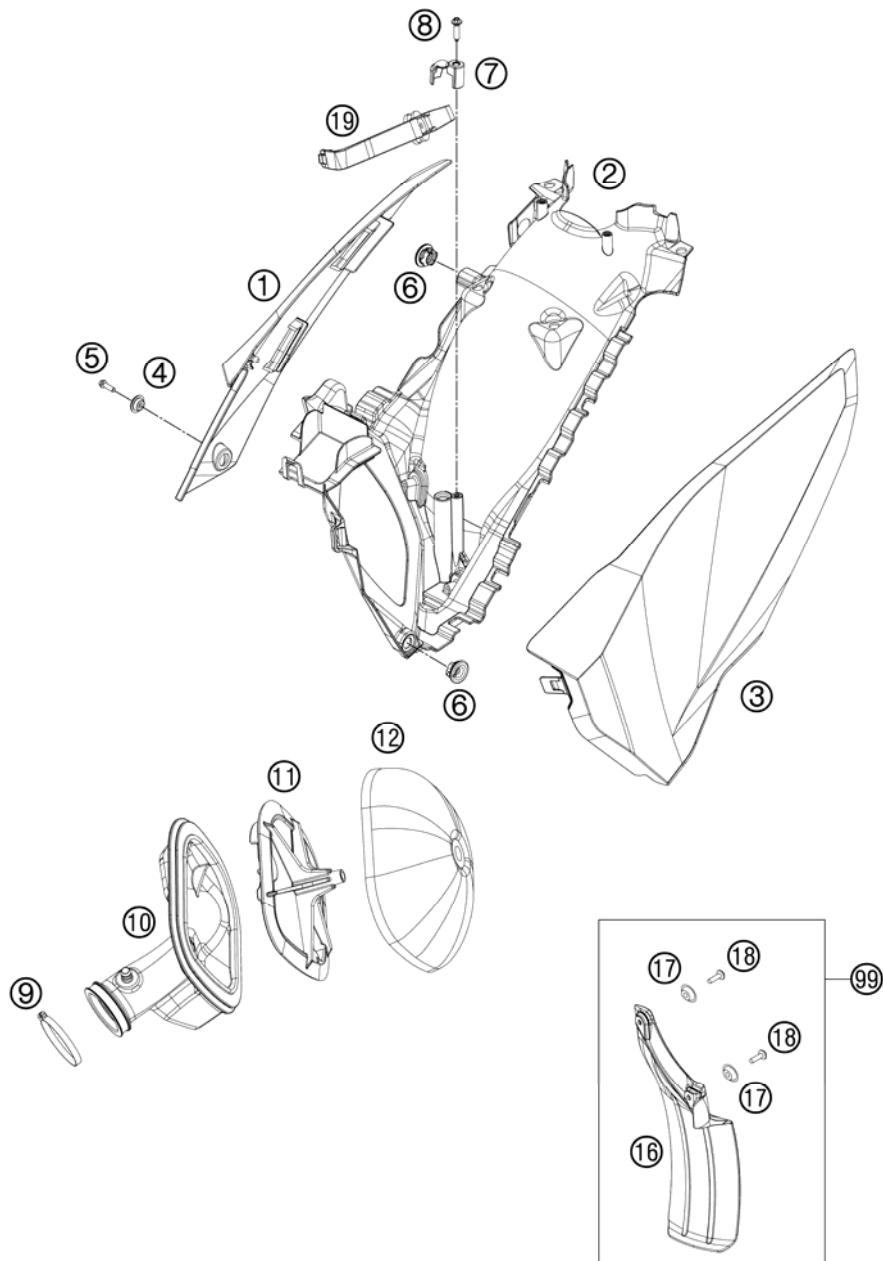

FIG	PART NUMBER	DESCRIPTION	QTY
1	8130600400028A	AIRFIL.BOX COVER R/S WITH DECAL	13
2	81306001000B0	FILTER WALL	1
3	8130600300028A	AIRFIL.BOX COVER L/S WITH DECAL	13
4	77308013010	COLLAR BUSH. F.REAR FENDER 07	1
5	0025060206	HH COLLAR SCREW M6X20 TX30	1
6	47106003160	QUICK CONNECTOR CLUTCH	2
7	81306001010	FIXING CAP	1
8	0017060203	EJOT PT SCREW K60X20 WS=6	1
9	78006027000	HOSE CLAMP 45-65MM	1
10	78106026000	AIRBOXG RUBBER 450 EFI	1
11	77206016000	FILTER CARRIER	11
12	77206015000	AIR FILTER	1
16	77306010000	FENDER FOR FILTER BOX	1
17	77304066050	BUSHING F. CHAIN SLIDING PR.07	2
18	0017060204	EJOT PT SCREW K60X20 ALU WS=6	2
19	81306017000	FILTER SUPPORT CPL.	1
99	77306010010	SPLASH PROTECTOR KIT SX/EXC	x

138130613 / C138130617

* NEW PART

X AS REQUIRED

TANK, SEAT, COVER

FE 501 USA 2013

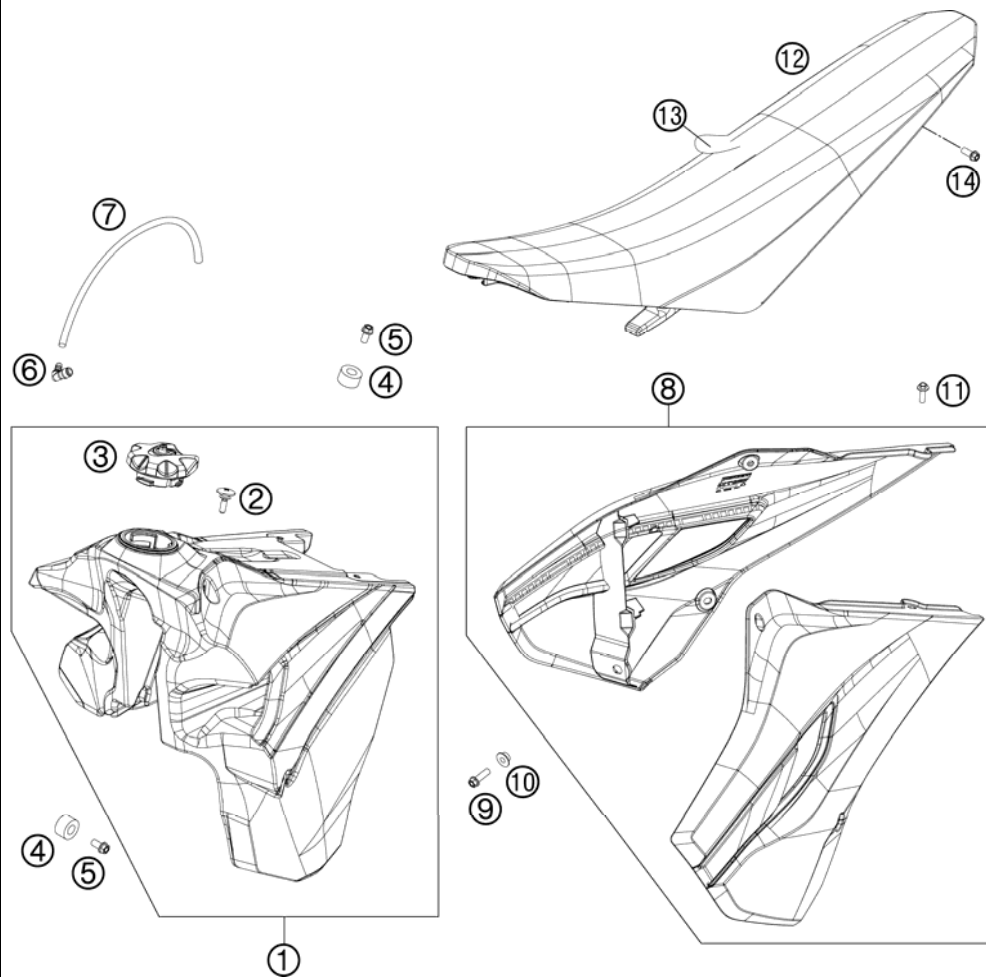

FIG	PART NUMBER	DESCRIPTION	QTY
1	8130751304499	BENZINTANK KPL. FE USA	1
2	50307011000	SCREW SEAT FASTENING D=6X23/18	1
3	7800700804455	TANK PLUG CPL. HUSABERG 09	1
4	50307014000	TANK ROLLER 12X26X12 '98	3
5	0026060136	COLLAR SCREW M6X13 ISA30	3
6	50330022000	ANGLE PIEC 90 DEGREE M10X1 02	1
7	78007000270	PVC-HOSE 5,6X10X270MM	1
8	8130805400068A	SPOILER SET BLUE 2013	1
9	0025060206	HH COLLAR SCREW M6X20 TX30	2
10	50308052000	BUSH FOR SPOILER 6X11X16X5 MM	2
11	0014050123	HH COLLAR SCREW M 5X12 WS=6	8
12	81207040000	SEAT FE 2009	1
13	81307040050	SEAT COVER	1
14	0025060206	HH COLLAR SCREW M6X20 TX30	2

138130713 / C138130713

* NEW PART

X AS REQUIRED



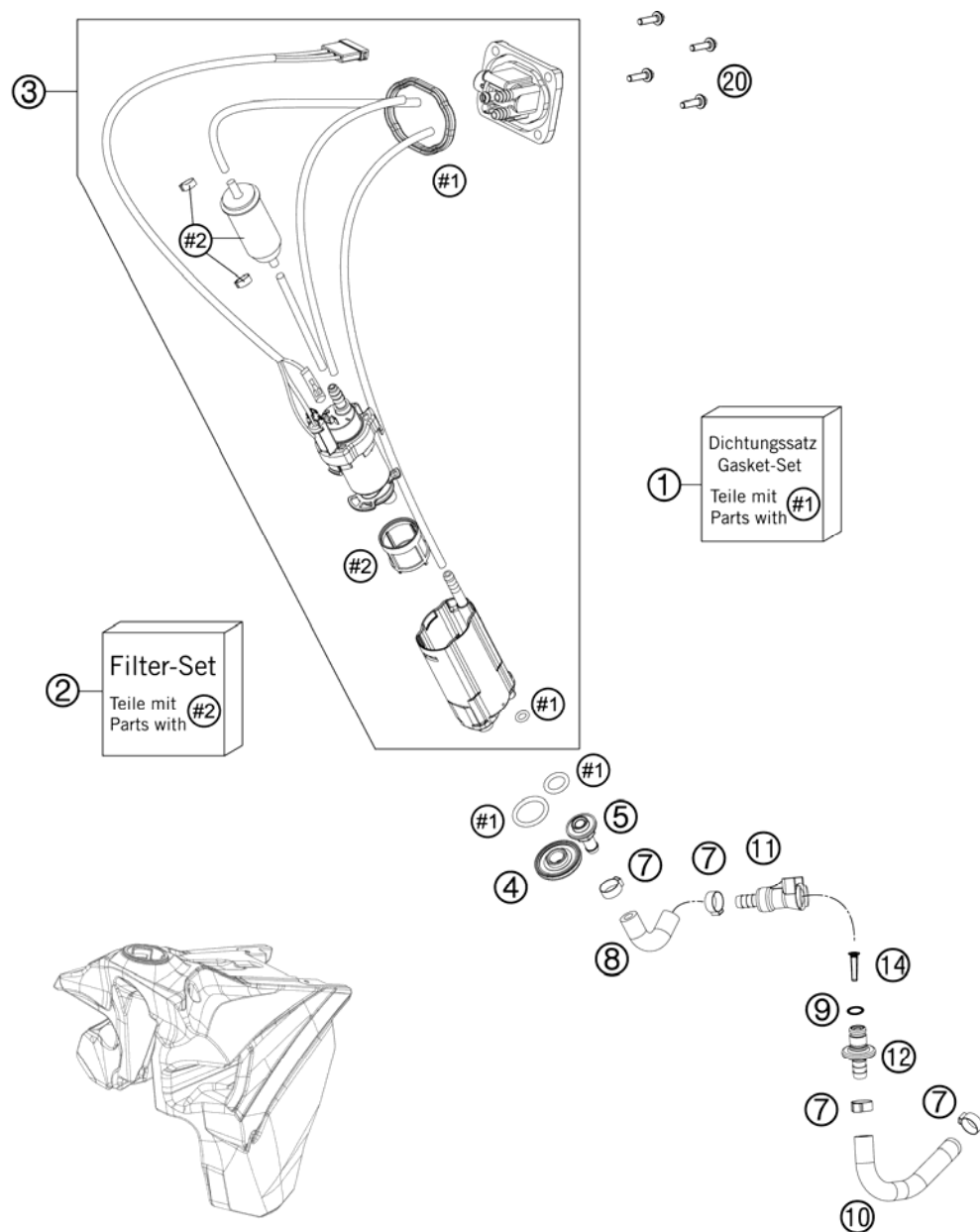

FIG	PART NUMBER	DESCRIPTION	QTY
1	78107089000	GASKET KIT	1
2	81207090000	FILTER KIT	1
3	78107088000	FUEL PUMP CPL. EXC	1
4	78107088014	NUT F. FUEL PUMP M12	1
5	78107088017	FUEL CONNECTOR M8	1
7	00050157706	VARIABLE ONE-EAR CLAMP 15,7MM	4
8	77407116100	FUEL HOSE TANK	1
9	58507012000	O-RING VITON F. PLUG CPC 05	1
10	77407016100	FUEL HOSE PREFORMED DKK	1
11	5850701050030	CLUTCH CPC BLACK 05	1
12	77707010000	CONNECTOR FUEL PUMP	1
14	78141013190	FUEL FILTER	1
20	0014050203	HH COLLAR SCREW M 5X20 WS=6	4

138130732 / C138130732

* NEW PART

X AS REQUIRED



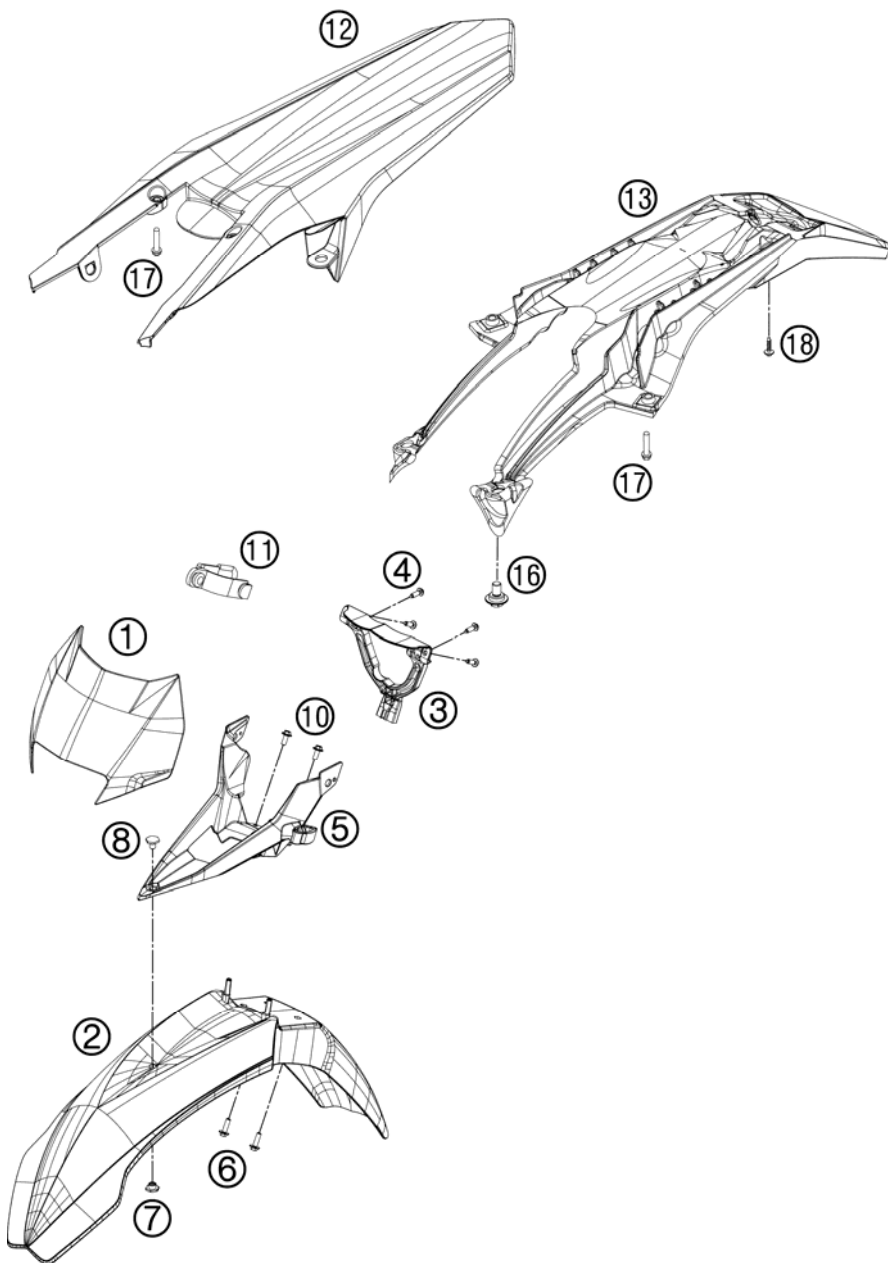

FIG	PART NUMBER	DESCRIPTION	QTY
1	8120800110028	HEADLIGHTMASK WHITE 2010	1
2	8130801000068	FRONT FENDER BLUE	1
3	81208003000	HEAD LIGHT SUPPORT 2009	1
4	0081050181	SCREW FOR PLASTIC K50X18 T20	4
5	81208009100B0	FENDER BRACE GREY	1
6	0025060206	HH COLLAR SCREW M6X20 TX30	4
7	50308009051	NUT FENDER BRACE M8 WS=17	1
8	50308009050	SCREW FEND.BRACE M8X9 WS=17	1
10	0024060156	HH COLLAR SCREW M6X15 TX30	2
11	50211086000	MASK RUBBER UFO WP '95	2
12	8130801300068	REAR FENDER BLUE 2013	1
13	81308015000	NUMBER PLATE CARRIER TOP	1
16	83008000012	SPECIAL SCREW M6X12X3	2
17	0025060256	HH COLLAR SCREW M6X25 TX30	2
18	0017060203	EJOT PT SCREW K60X20 WS=6	4

138130811 / C138130811

* NEW PART

X AS REQUIRED



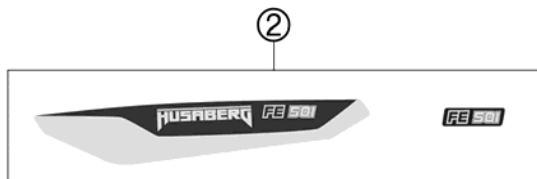
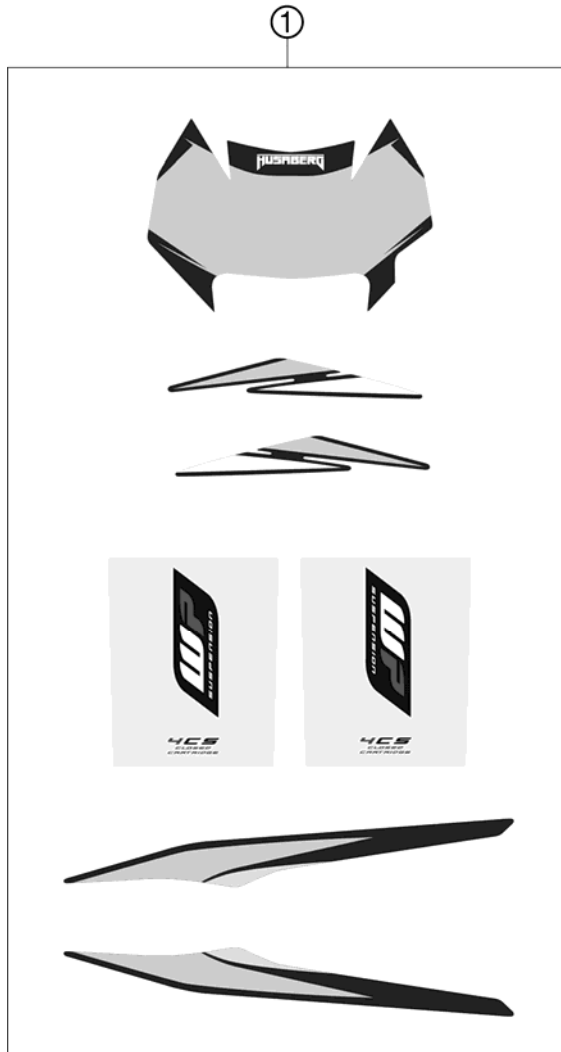

FIG	PART NUMBER	DESCRIPTION	QTY
1	81308099000	DECAL KIT HUSABERG FE 2013	1
2	81308097300	DISPLACEMENT STICKER 501FE	1

138130836 / C138130836

* NEW PART

X AS REQUIRED

FRONT WHEEL

FE 501 USA 2013

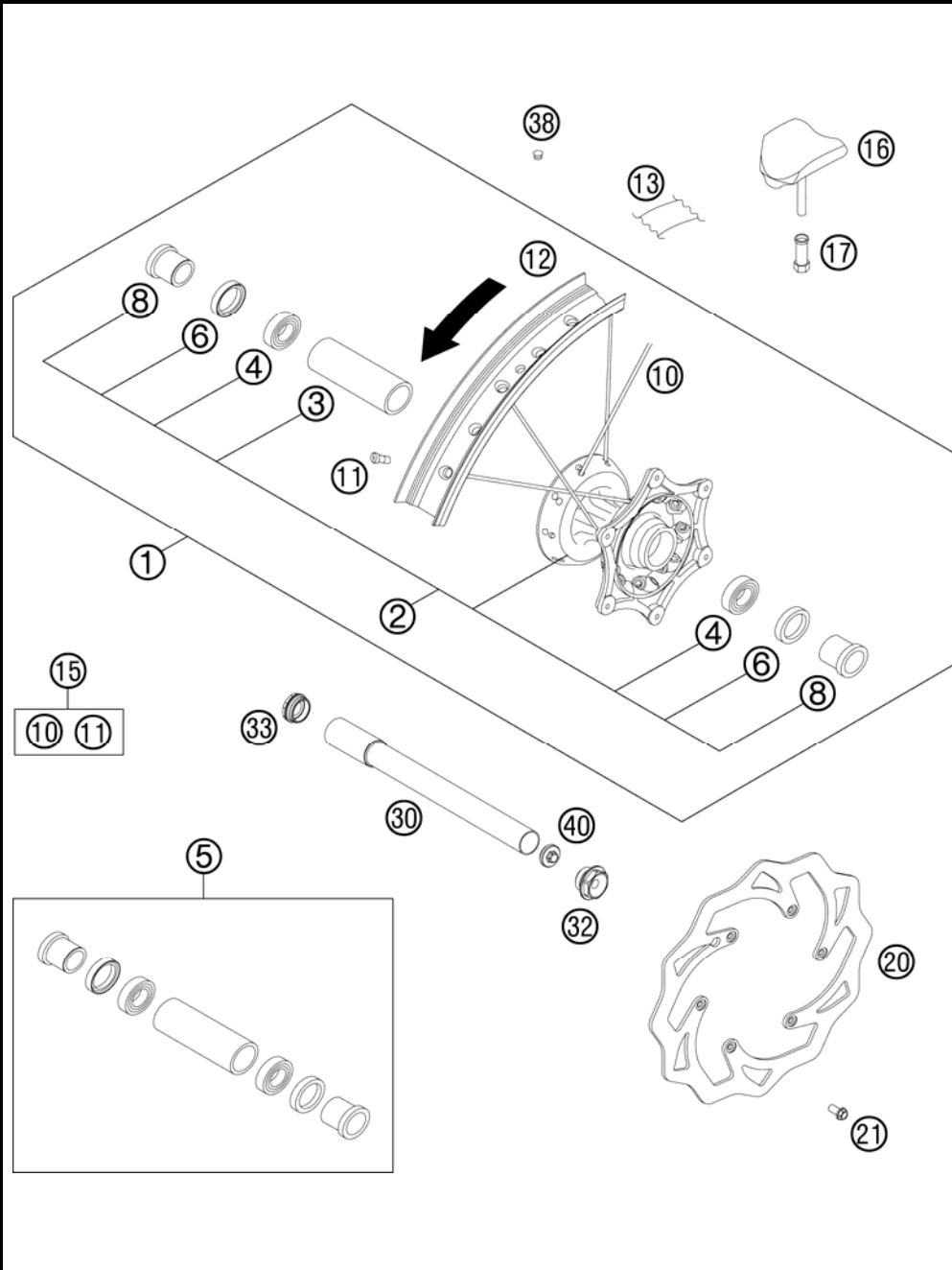

FIG	PART NUMBER	DESCRIPTION	QTY
1	8130900104468	FRONT WHEEL CPL. 1,60X21" 13	1
2	78009010144	FRONT WHEEL HUB CPL.	1
3	54809011000	BEA.SPACERTUBE 35X2 L=79,4 03	1
4	0625069068	GR.BALL BEAR.6906 DDU2CG23S6NM	2
5	78009015000	FRONT WHEEL REP. KIT	1
6	0760354771	SHAFT SEAL RING 35X47X7 TC	2
8	78009012000	SPACER BUSHING F. FR. WHEEL 08	2
10	7710907122630	SPOKE M4,5X226- 21" BLACK 12	36
11	77109072000	SPOKE NIPPLE M4,5 AL 11	36
12	8120907010068	RIM FRONT 1,6X1" DID AL7 BLUE	1
13	50309073000	RIM BAND 21"	1
15	00050000954	SPOKE KIT FRONT "21" BLACK	x
16	78109090000	RIM LOCK 1,60"	1
17	77110090050	NUT FOR WHEEL HOLDER	1
20	77309060000	BRAKE DISC FRONT 260	1
21	59009062013	SPECIAL SCREW M6X13 WS=8 10.9	6
30	77309081000	WHEEL SPIN.FR. D=26 M24x1,5 07	1
32	54809082000	SPINDLE SCREW M24X1,5 WS=27 03	1
33	54809081050	PLUG BUSHING WS=27 03	1
38	55003135000	PLUG FOR RIM	x
40	54809081070	AUXILIARY SCREW FRONT 06	1

117710910 / C138130910

* NEW PART

X AS REQUIRED



REAR WHEEL

FE 501 USA 2013

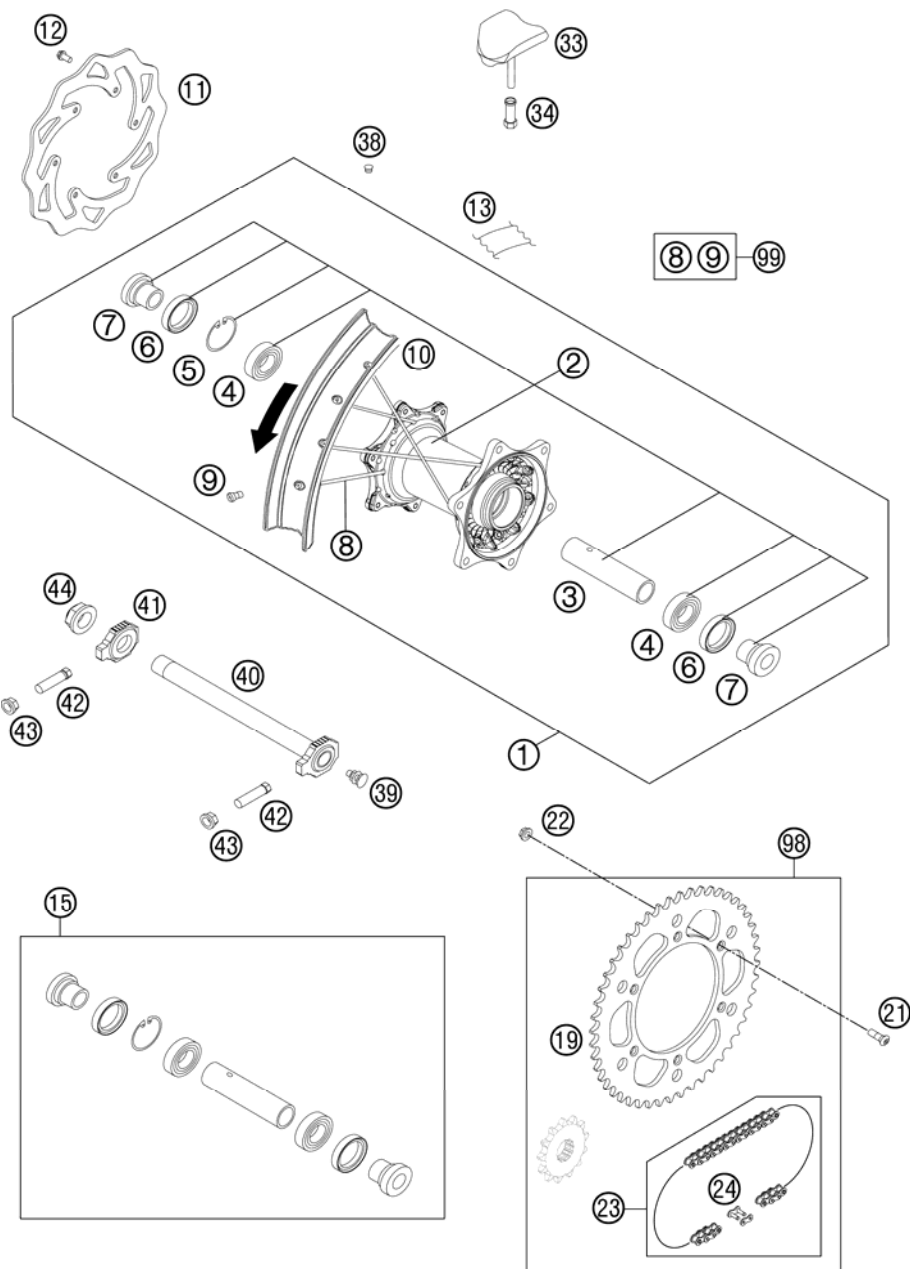

FIG	PART NUMBER	DESCRIPTION	QTY
44	50310099000	HEXAGON NUT M20X1,5 '98	1
98	00050002008	DRIVETRAIN KIT EXC/XC 14T/50T	x
99	00050000958	SPOKE KIT REAR 18" BLACK	x

125481010 / C138131011

* NEW PART

X AS REQUIRED



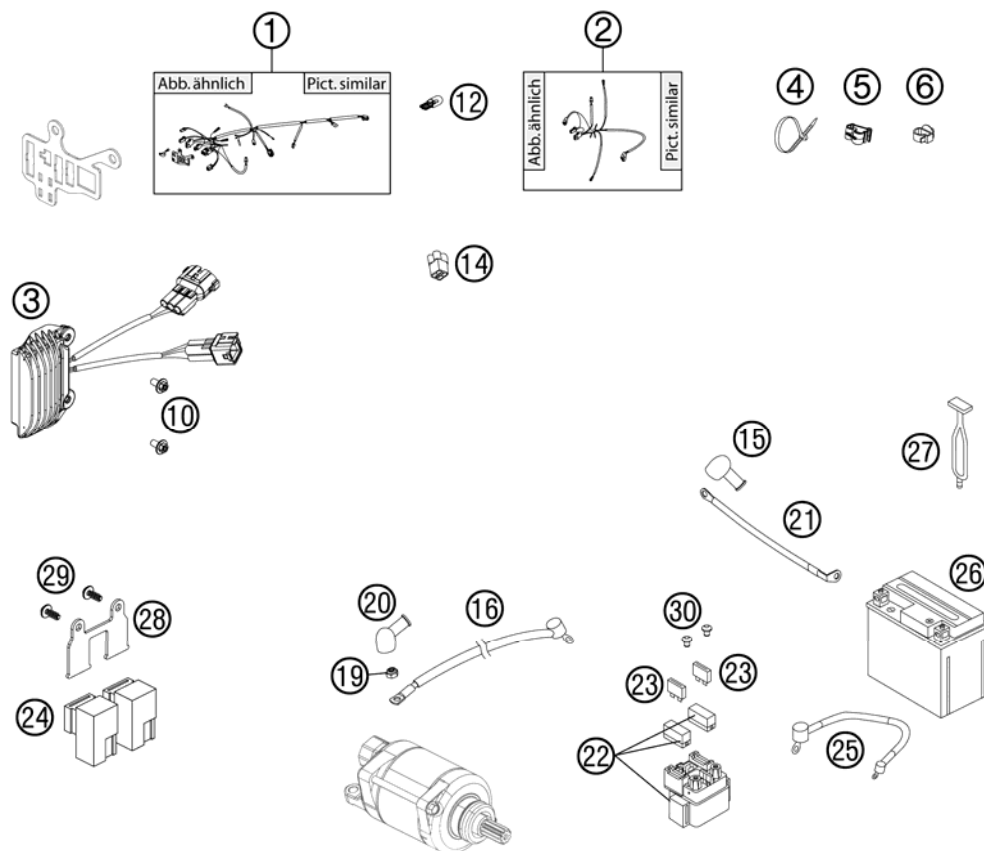

FIG	PART NUMBER	DESCRIPTION	QTY
1	78111075033	WIRING HARNESS EFI VMT. EU/AUS	1
2	78111079100	WIRING HARNESS LIGHT XC-W 2012	1
3	78111034000	VOLTAGE REGULATOR	1
4	44011076140	CABLE TIE 140/2,5MM BLACK	x
4	44011076200	CABLE TIE 200/3,6MM BLACK	x
4	44011076305	CABLE TIE 300/4,8MM BLACK	x
5	83013026000	CABLE GUIDE	2
6	58111076000	CABLE SUPPORT KHS NR.150-47610	1
10	0023060123	COLLAR SCREW M6X12 TX	2
12	49111425200	BULB 12V 2,3W (W2X4,6D)	1
14	81211096000	DUMMY PLUG AN 4-PIN	1
15	81311040000	PROTECTION CAP F. GROUND	1
16	81311059000	STARTER CABLE	1
19	0985060003	SELF LOCK. NUT DIN0985-M 6	1
20	77240099000	PROTECTION CAP F. STARTER ENG.	1
21	76211097000	GROUND CABLE	1
22	76211058000	STARTER RELAY 07	1
23	58011109120	FUSE 20 A	2
24	61111057000	RELAY CM1A-R-12V-H80 07	2
25	81311059050	WIRING HARNESS BATTERY	1
26	58511053000	BATTERY 12V 4AH YTX5L-BS	1
27	50303018000	RUBBER L=145MM	2
28	81311037000	BRACKET POWERRELAIS	1
29	0081050121	SCREW FOR PLASTIC K50X12 T20	2
30	0902060083	AH OVAL SCREW ISO 7380 M 6X8	2

138131113 / C138131116

* NEW PART

X AS REQUIRED

HAND BRAKE CYLINDER

FE 501 USA 2013

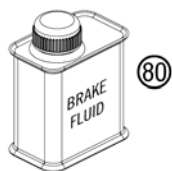
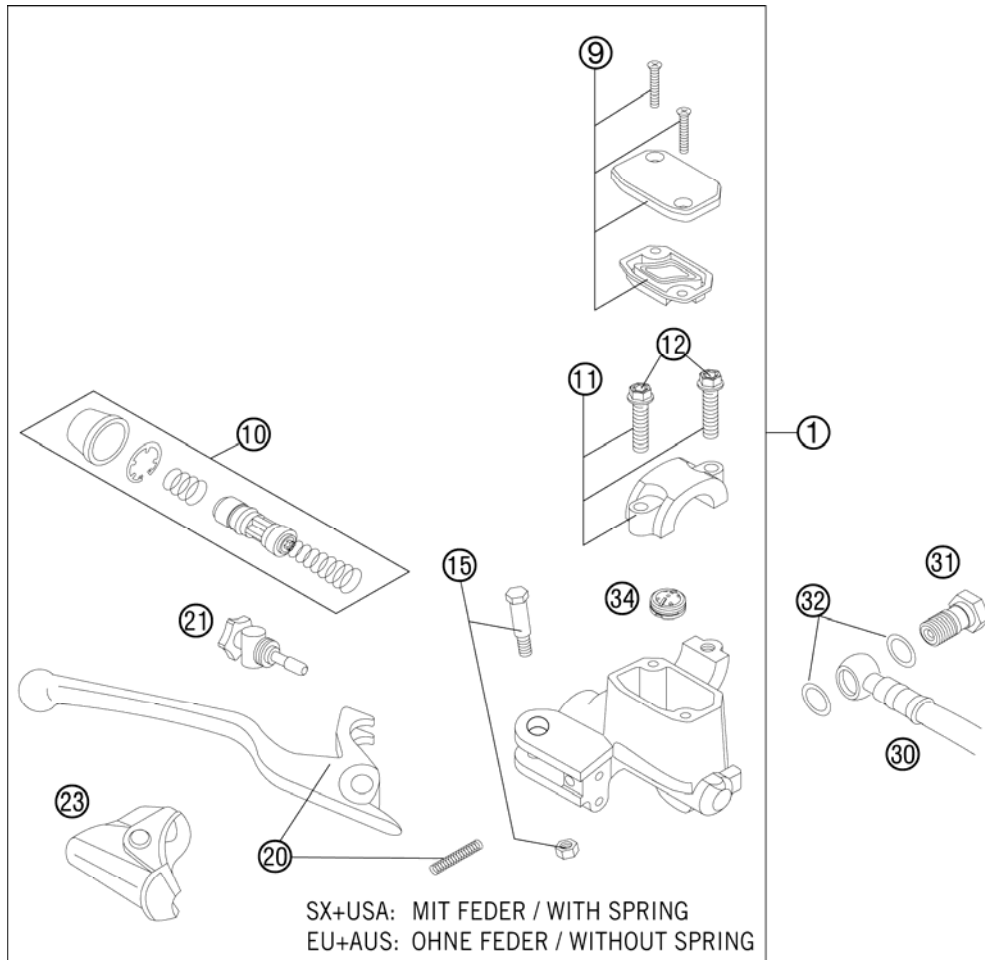

FIG	PART NUMBER	DESCRIPTION	QTY
1	77013001044	HAND BRAKE CYLINDER CPL. SX 09	1
9	50313003000	HANDBRAKE CYL. COVER CPL. NATURE	1
10	54813008300	REP. SET PISTON D=9MM 2009	1
11	50313005000	CLAMP CPL. NATURE	1
12	0025060256	HH COLLAR SCREW M6X25 TX30	2
15	50313006100	LEVER SCREW CPL. 2001	1
20	54813002200	HAND BRAKE LEVER + SPRING 2009	1
21	54813007300	ADJUSTING SCREW CPL. SX 2009	1
23	50313004000	PROTECTION CAP HAND BRAKE CYL.	1
30	59013011000	BRAKEHO. FRONT 1300MM 2000	1
31	54813020100	HOLLOW SCREW BLACK M10X1X19	1
32	0603100141	COPPER GASKET DIN7603-10X14X1	2
34	54802051000	VALVE	1
80	00062030000	BRAKE FLUID DOT5.1 0,25L	1

127811310 / C127811310

* NEW PART

X AS REQUIRED



BRAKE CALIPER FRONT

FE 501 USA 2013

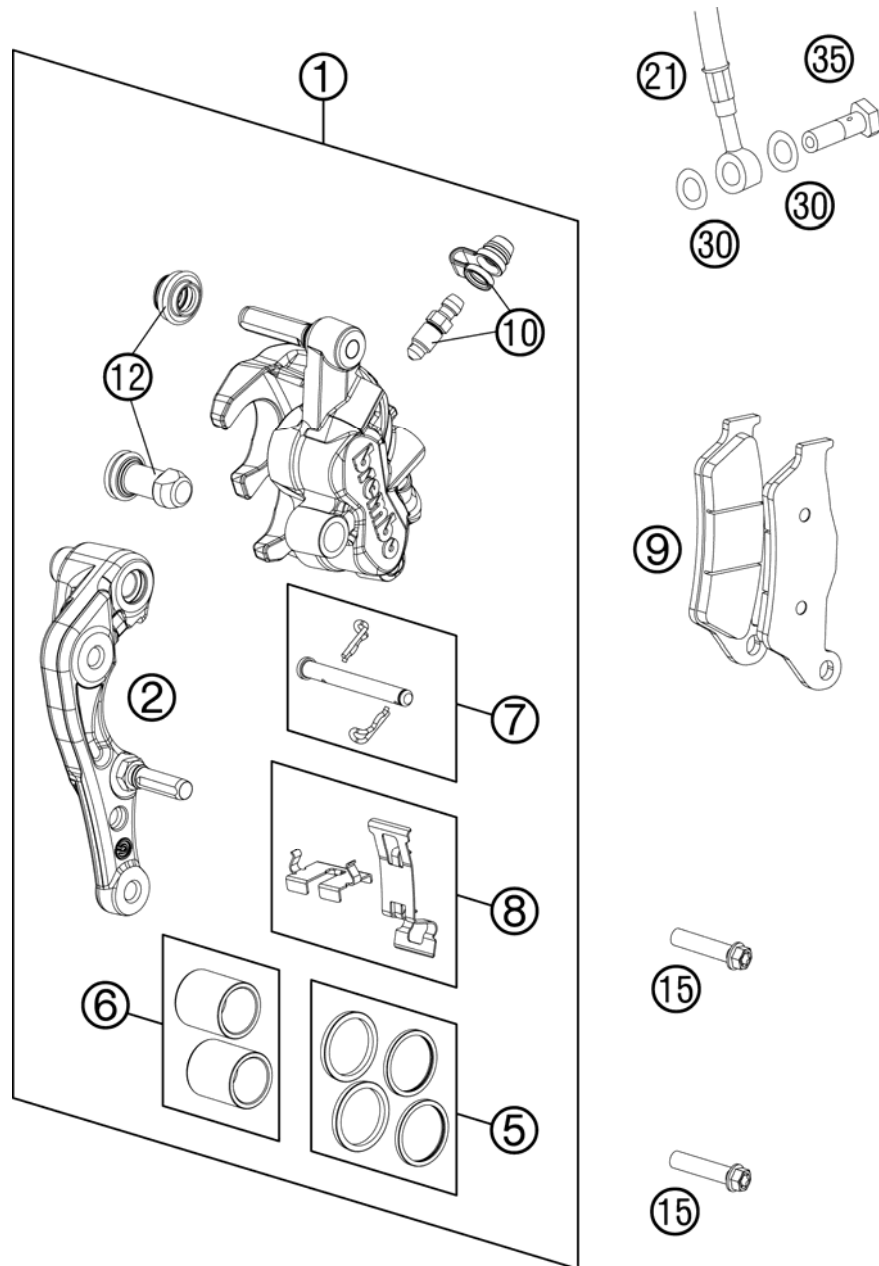

FIG	PART NUMBER	DESCRIPTION	QTY
1	7701301500101	CALIPER NAT. WITHOUT PADS	1
2	77013014000	BRAKE CALIPER SUPPORT FRONT 09	1
5	77013021000	REP. KIT SEALS 24MM	1
6	77013019000	REP. KIT PISTON 24MM	1
7	77013017000	BOLT CPL. 09	1
8	77013018000	RETAINING PLATE SET BREMBO	1
9	77013020000	BRAKE PADS TOYO B153	1
10	61013020100	BLEEDER SCREW WITH CAP	1
12	54613218000	CUP SET SHORT	1
15	0025080356S	HH COLLAR SCREW M8X35 TX40	2
21	59013011000	BRAKEHO. FRONT 1300MM 2000	1
30	0603100141	COPPER GASKET DIN7603-10X14X1	2
35	50213025000	HOLLOW SCREW M10X1X19	1

117711360 / C127811360

* NEW PART

X AS REQUIRED



BRAKE CALIPER REAR

FE 501 USA 2013

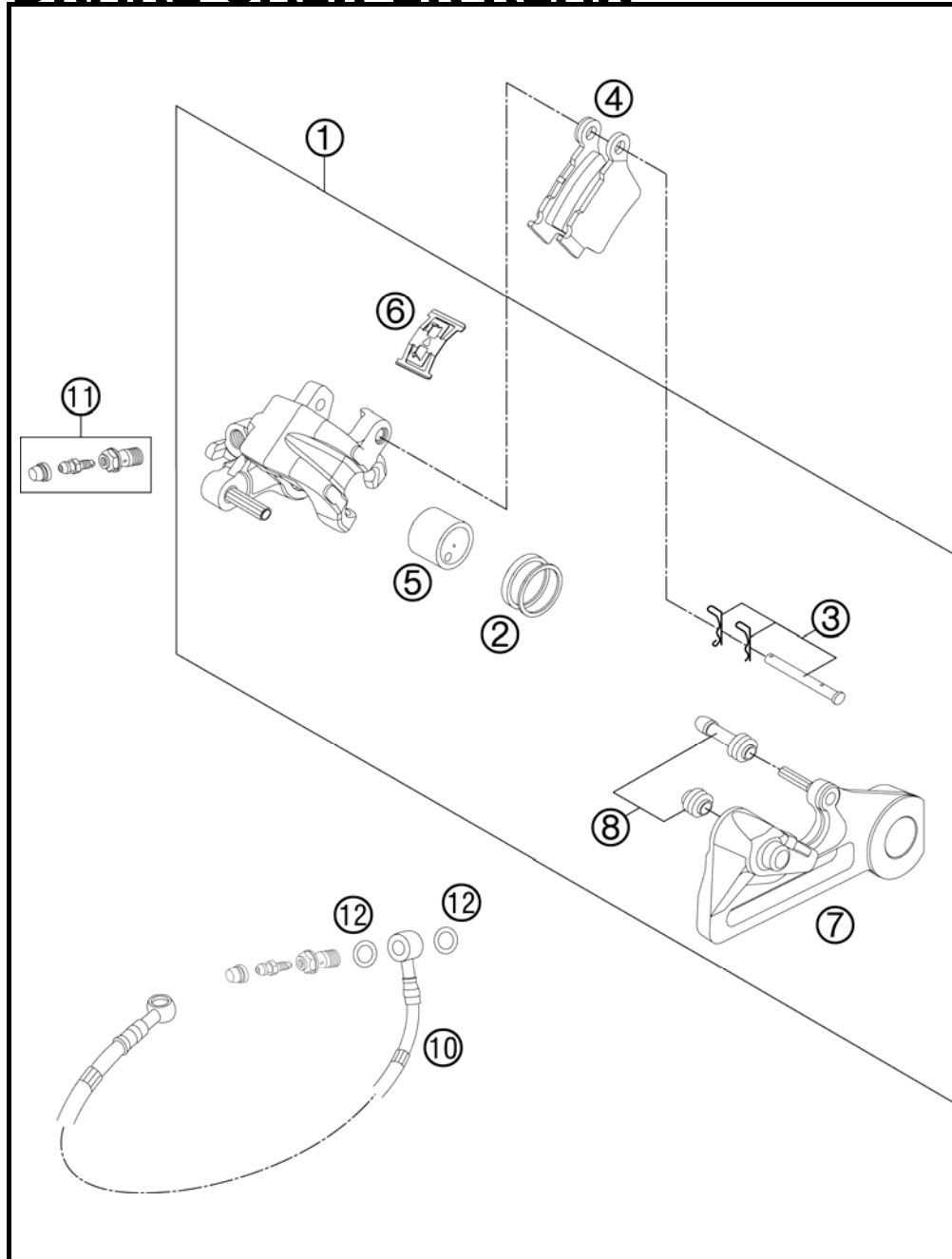

FIG	PART NUMBER	DESCRIPTION	QTY
1	54813080101	BRAKE CAL. RE. - WITHOUT PADS	1
2	50313081200	REPAIR KIT SEALING RINGS 26MM	1
3	54813082000	BOLT SET FOR BRAKE CALIPER 03	1
4	54813090300	BRAKE PAD SET REAR TOYO	1
5	54813083000	BRAKE PISTON 26MM 2003	1
6	54813018000	RETAINING SPRING SET 2003	1
7	54813075000	BRAKE CALIPER SUPPORT REAR	1
8	54613218000	CUP SET SHORT	1
10	54813070000	BRAKE HOSE REAR 655MM 03	1
11	62513020000	BLEEDER SCREW CPL. 05	1
12	0603100141	COPPER GASKET DIN7603-10X14X1	2

127811390 / C127811390

* NEW PART

X AS REQUIRED



REAR BRAKE CONTROL

FE 501 USA 2013

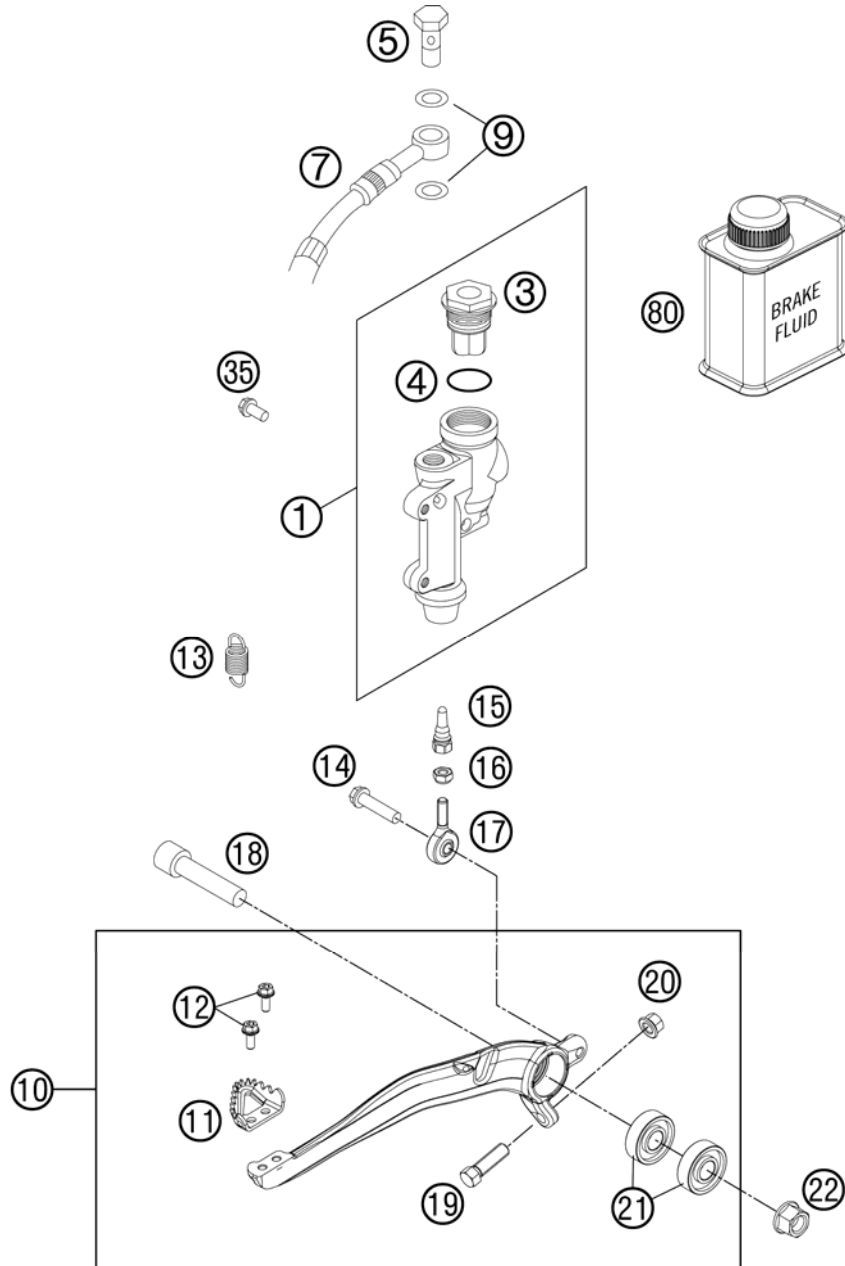

FIG	PART NUMBER	DESCRIPTION	QTY
1	77013060044	REAR BRAKE CYLINDER CPL.SX 09	1
3	54813062100	REAR BRAKE CYL. COVER CPL. 04	1
4	54813063000	FOOT-BRAKE CYL. GASKET SX 03	1
5	54813020100	HOLLOW SCREW BLACK M10X1X19	1
7	54813070000	BRAKE HOSE REAR 655MM 03	1
9	0603100141	COPPER GASKET DIN7603-10X14X1	2
10	77213050044	FOOT BRAKE LEVER CPL.	1
11	54813051000	STEP PLATE FOR BRAKE LEVER	1
12	0025050126	HH COLLAR SCREW M5X12 TX30	2
13	54603062000	RETURN SPRING FOR BRAKE LEVER	1
14	0025060206	HH COLLAR SCREW M6X20 TX30	1
15	54813056000	PUSH ROD L=28MM 03	1
16	0934060003	HEXAGON NUT DIN0934-M 6	1
17	54813055000	SWIVEL HEAD KA6 03	1
18	0032100406S	AH-COLLAR SCREW M10X40 ISA45	1
19	59001037000	SPECIAL SCREW M8X26 WS=10	1
20	46030045000	COLLAR NUT M8 WS=10	1
21	0625060002	BALL BEARING SKF 6000-2RS1	2
22	54630044000	COLLAR NUT M10 WS=13	1
35	0025060126	HH COLLAR SCREW M6X12 TX30	2
80	00062030000	BRAKE FLUID DOT5.1 0,25L	1

125031330 / C138131331

* NEW PART

X AS REQUIRED



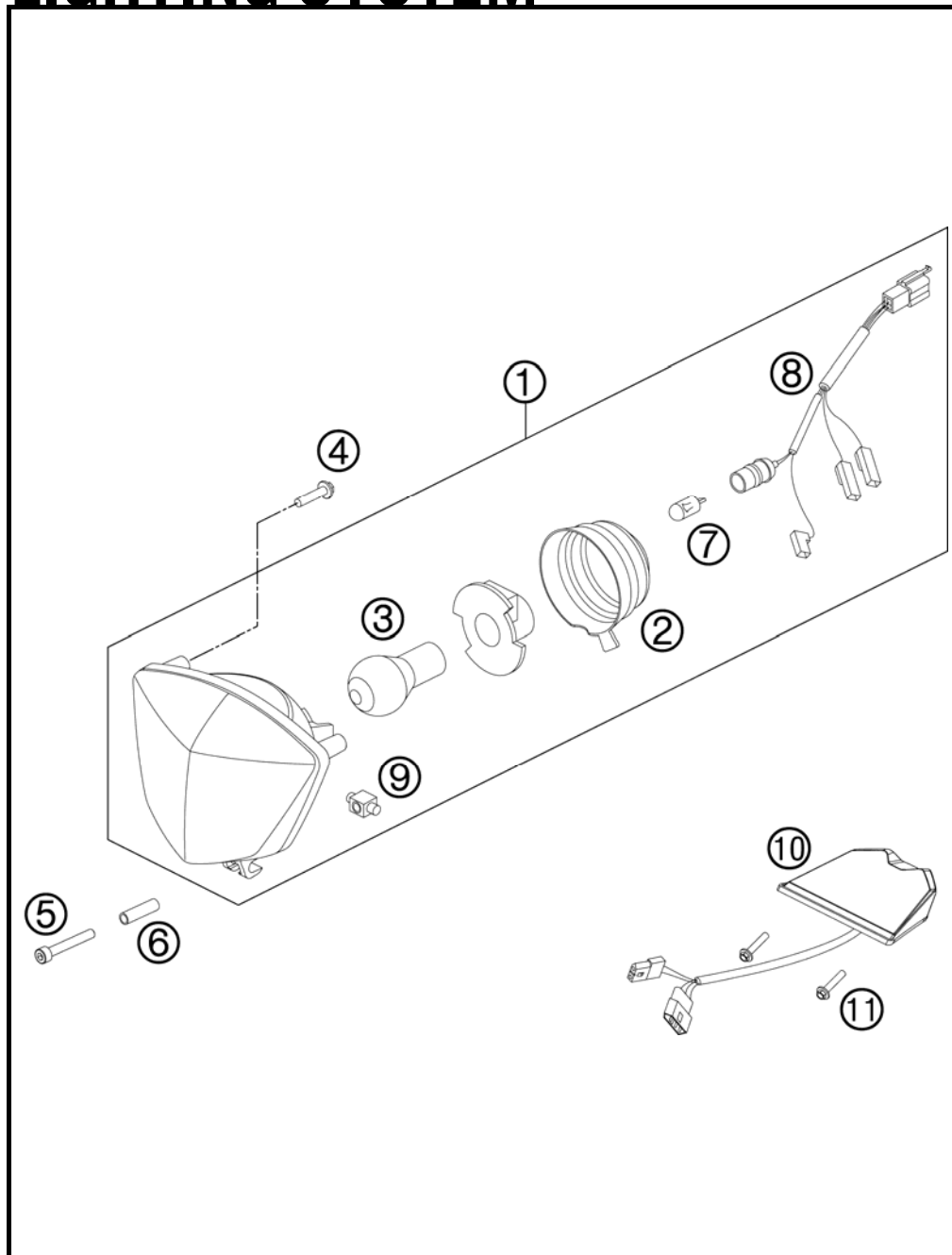

FIG	PART NUMBER	DESCRIPTION	QTY
1	81214001000	HEAD LIGHT	1
2	54814001050	RUBBER CAP FOR HEAD LIGHT 05	1
3	44111038000	BILUX-BULB 12V 35/35W BA20D	1
4	0081050181	SCREW FOR PLASTIC K50X18 T20	3
5	0912050353	AH SCREW DIN912 M5X35	1
6	81208008000	DIST. HOSE F. HEAD LIGHT MASK	1
7	49011435100	BULB 12V 5W (W2,1X9,5D) PHIL.	1
8	54811001050	CABLE FOR HEAD LIGHT 2005	1
9	81208003010	INSERT FOR HEAD LIGHT SUPPORT	1
10	76514040000	REAR LIGHT	1
11	0017060253	EJOT PT SCREW K60X25-Z SW=6	2

138131411 / C138131411

* NEW PART

X AS REQUIRED



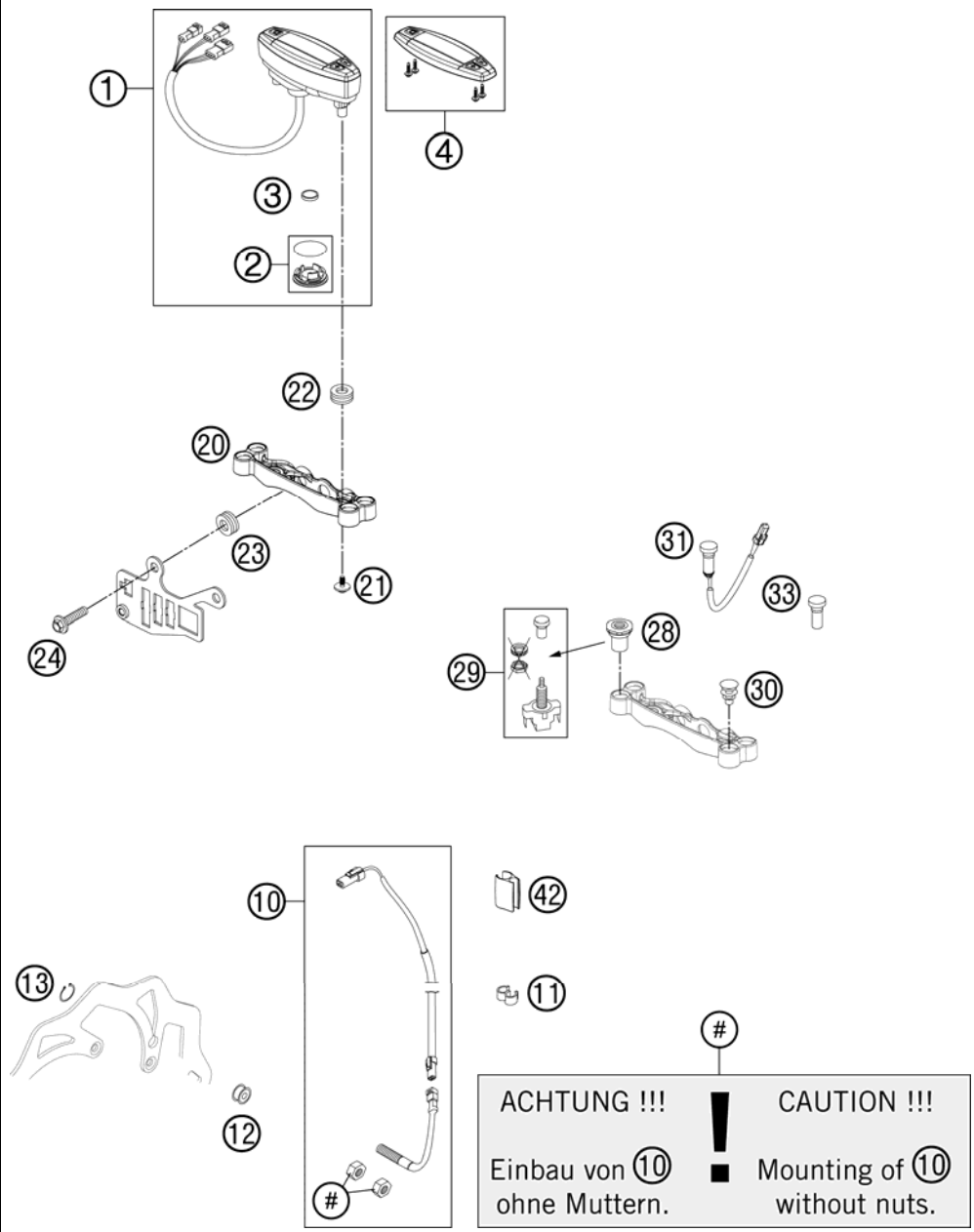

FIG	PART NUMBER	DESCRIPTION	QTY
1	54814069100	SPEEDOMETER MPH F. 21" 2005 REPROGRAMMABLE: MPH - KM/H	1
2	54814069010	BATTERY COVER F. SPEEDOM. 2005	1
3	58314068000	BATTERY F. SPEEDOM. M.A.E. 02	1
4	54814069020	SPEEDOMETER TOP PART 05	1
10	54814068100	CABLE FOR DIGITAL SPEEDOM. 06	1
11	60111094000	CLAMP 5/7 MM 06	2
12	54814069050	MAGNET FOR DIGITAL SPEEDOM. 03	1
13	0471009104	CIRCLIP DIN0471- 9X1 INOX	1
20	81214060000	SPEEDOMETER BRACKET	1
21	0081645121	EJOT DELTA PT SCREW 45X12-Z	2
22	58214069051	RUBBER GROMMET 16X10,8X3 02	2
23	31008060000	RUBBER SLEEVE D=8MM OPEN	2
24	0024060256	HH COLLAR SCREW M6X25 TX30	2
25	59030060050	BUSHING F. SPROCKET COVER RAC.	2
28	54814060050	SPEC. NUT F. PULL SWITCH WS=17	1
29	55011599000	PULL SWITCH LOOSE	1
30	50210086000	COVERING CAP SFL16	1
31	81214083000	INDICATOR LIGHT LED YELLOW FI	1
33	81214086000	INDICATOR LIGHT RESERVE	1
42	54813026000	CABLE SUPPORT 10/6MM 06	2

127741430 / C138131433

* NEW PART

X AS REQUIRED



①
OHNE ABBILDUNG
WITHOUT ILLUSTRATION

①
TECHNISCHE DOKUMENTATION
TECHNICAL DOCUMENTATION
DOCUMENTACION TECNICA
DOCUMENTATION TECHNIQUE
NOTE TECNICHE

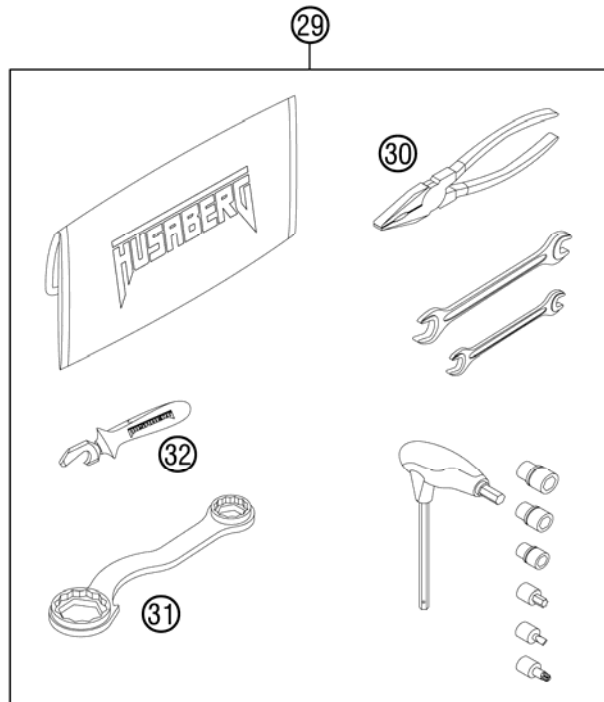

FIG	PART NUMBER	DESCRIPTION	QTY
0	00062030019	AIR FILTER OIL 100ML	1
0	00063004202	PRINT LABEL 60X51 MM	2
0	0025050126	HH COLLAR SCREW M5X12 TX30	2
0	52000115	STICKER FRONT FORK-SET WP"4CS"	1
0	58411098100	CONTACT WASHER M6 VSV-K6	2
0	58511053000	BATTERY 12V 4AH YTX5L-BS	1
0	78003040033	FOOTREST L/S + R/S CPL. 09	1
0	78029072000	SPARK PLUG SOCKET	1
0	7810297910028	HANDGUARD MX CPL. WHITE	1
0	78103190100	SKID PLATE PLASTIC CPL.	1
0	81202002144	BAR PAD CPL.	1
0	81211096000	DUMMY PLUG AN 4-PIN	1
0	81212002000	BAG HUSABERG	1
0	81212016100	WASH CAP SET	1
0	H38090110	HUSABERG BALLPOINT PEN	1
1	3802035EN	OWNERS MANUAL 450/501 FE 2013	1
29	81229099000	TOOL SET 2009	1
30	53012028200	GRIP ORANGE B&F	1
31	50329080100	WRENCH SW=17/21/27/32 B&F	1
32	81229071000	OPENER HUSABERG	1

118122001 / C138132009

* NEW PART

X AS REQUIRED





HUSABERG – a company of the KTM Group
A-5230 Mattighofen
www.husaberg.cc

KTM Group Partner



3CFF2475M3EN



Art.Nr.: 3CFF2475M3EN 8/2012