

EVO 2T 2016
125/200/250/300cc

CATALOGO PARTI DI RICAMBIO
CATALOGUE OF SPARE PARTS
CATALOGUE PIECES DE RECHANGE
ERSATZTEILKATALOG
CATALOGO DE PIEZAS DE REPUESTO

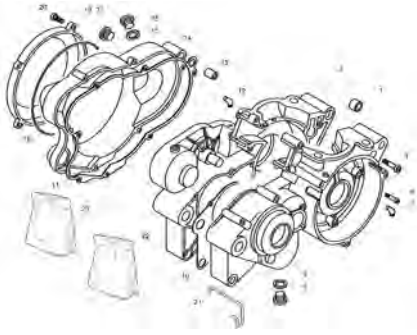

TAV.01 Basamento - Crankcase - Carter - Kurbelgehäuse - Carter



Pag. 6

TAV.02 Albero motore-Pistone-Gruppo termico - Crankshaft-Piston-Thermal unit - Vilebrequin-Piston-Gr. Thermique - Kurbelwelle-Kolben-Thermischen Gruppe - Cigüeñal-Pistón-Grupo térmico



Pag. 8

TAV.03 Frizione - Clutch - Embrayage - Kupplung - Embrague

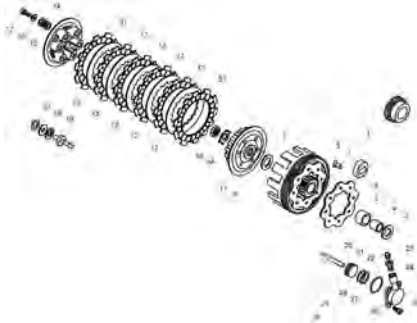

Pag. 12

TAV.04 Ingranaggi cambio - Gear group - Engrenages changement de vitesses - Schaltgetriebe - Engranaje del cambio

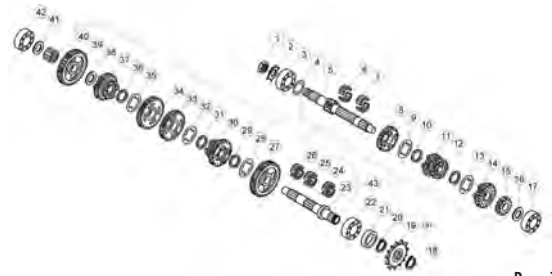

Pag. 14

TAV.05 Comando cambio - Gear shift control - Commande changement de vitesse - Chaltung - Mando cambio

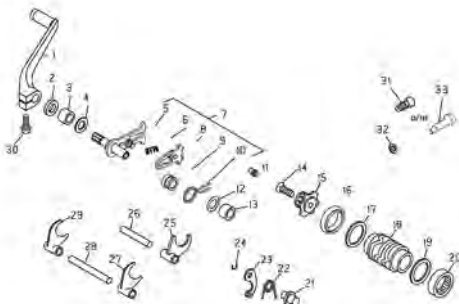

Pag. 16

TAV.06 Avviamento a pedale - Kickstarter - Dé marrage à pedal - Pedalstart - Arranque a pedal

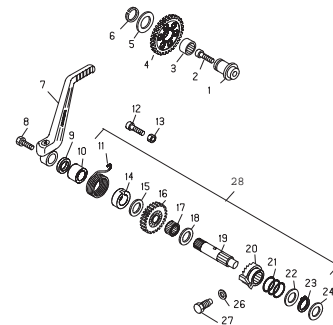

Pag. 18

TAV.09 Impianto di lubrificazione - Lubrication system - Système de lubrification - Schmieranlage - Sistema de lubricación

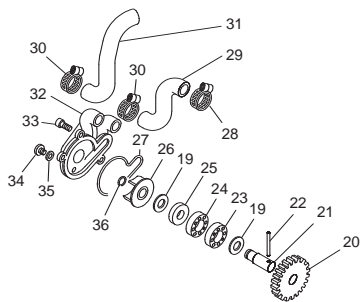

Pag. 20

TAV.10 Gruppo accensione elettronica - Electronic ignition assy. - Groupe allumage électronique - Elektronischezündgruppe - Grupo encendido electrónico

125-200cc

250-300cc



Pag. 21

Pag. 22

TAV.12A Carburatore - Carburettor - Carburateur - Vergaser - Carburador

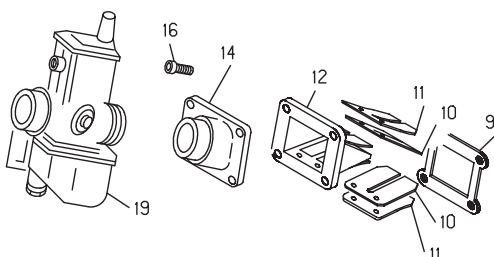

Pag. 23

TAV.12B Componenti del carburatore - Carburettor component parts - Pieces composant le carburateur - Vergasersbauteile - Componentes del carburador

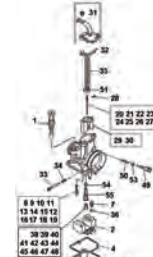

Pag. 24



TAV.14 Attrezzatura specifica - Outillage spéciale - Special tools - Spezialwerkzeug - Utillaje específico

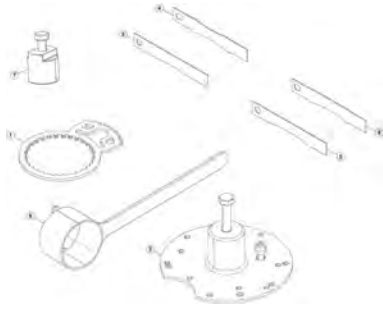

Pag. 26

TAV.31 Telaio - Frame - Chassis - Rahmen - Chasis

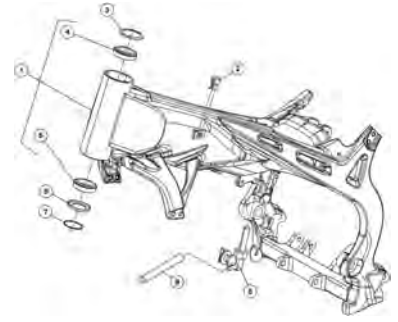

Pag. 27

TAV.32 Accessori telaio - Frame accessories - Accessoires chassis - Rahmenzubehör - Accesorios Chasis



Pag. 28

TAV.33 Forcellone posteriore - Rear fork - Fourche arrière - Hinterradschwinge - Horquilla posterior



Pag. 30

TAV.33A Ammortizzatore posteriore - Amortisseur arrière - Rear shock absorber - Hinterer Stoßdämpfer - Amortiguador trasero

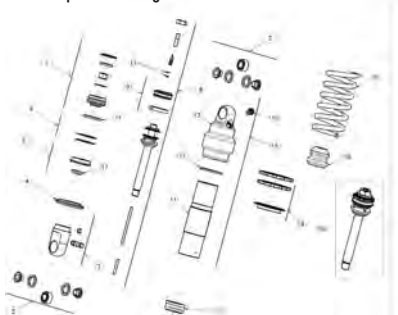

Pag. 34

TAV.34 Forcella anteriore - Front fork - Fourche AV - Vorderradgabel - Horquilla delantera



Pag. 36

TAV.35 Comandi-Manubrio - Controls-Handlebars - Commandes-Guidon - Bedienungselemente-Lenker - Mandos-Manillar

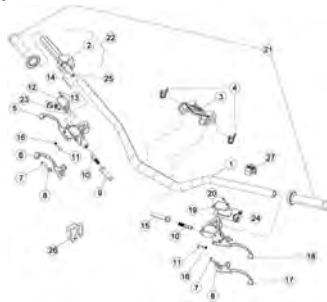

Pag. 38

TAV.36 Impianto freni idraulici - Hydraulic brakes system - Installation des freins hydrauliques - Hidraulischebremse anlage - Instalación freno hidráulico

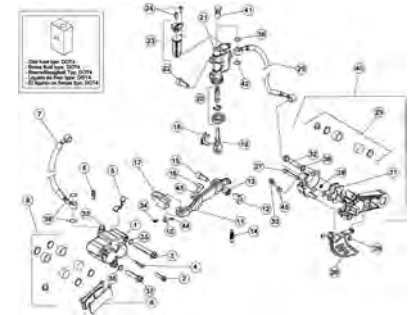

Pag. 40

TAV.37 Gruppo scarico - Exhaust system - Echappement - Auspuffanlage - Grupo escape

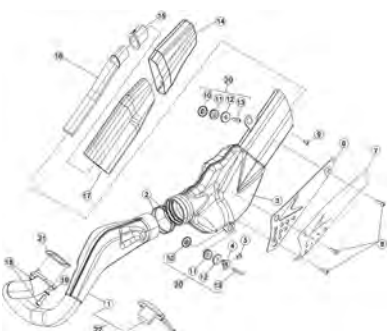

Pag. 42

TAV.38 Scatola filtro - Filter box - Boî tier du filtre - Sicherungskasten - Caja del filtro

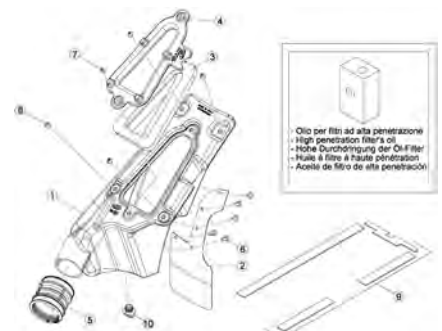

Pag. 44

TAV.39 Impianto di raffreddamento - Installation de refroidissement - Installation de refroidissement - Kühlsystem - Instalación de enfriamiento



Pag. 45

TAV.40 Impianto elettrico - Electrical equipment - Installation électrique - Elektrische anlage - instalación eléctrica

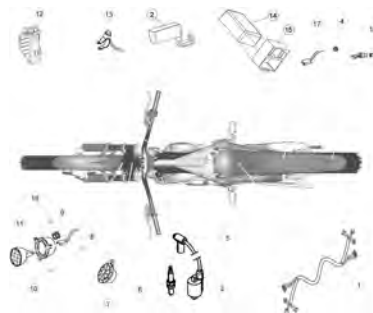

Pag. 46

TAV.41 Ruota anteriore - Front wheel - Roue AV. - Vorderrad - Rueda delantera

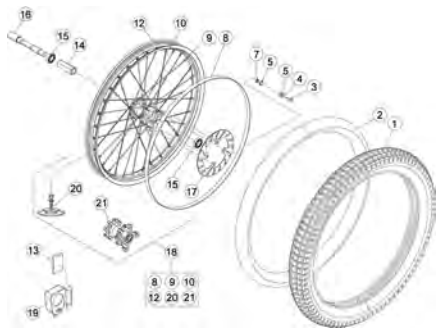

Pag. 47

TAV.42 Ruota posteriore - Rear wheel - Roue AR. - Hinterrad - Rueda trasera

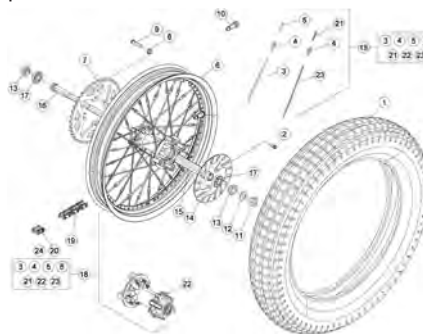

Pag. 48

TAV.43 Carenature-Serbatoio-Sella - Fairings-Tank-Saddle - Carenages-Reservoir-Selle - Verkleidungen-Tank-Sattel - Carenados-Deposito-Sillín

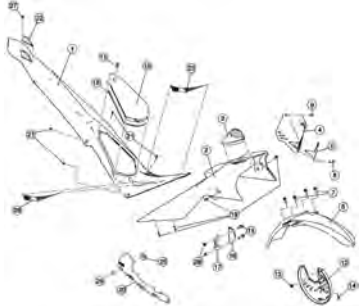

Pag. 50

TAV.43A Decalco - Decalcomania - Decalcomanie - Abziehbild - Calcomania



Pag. 52



Tav.1A

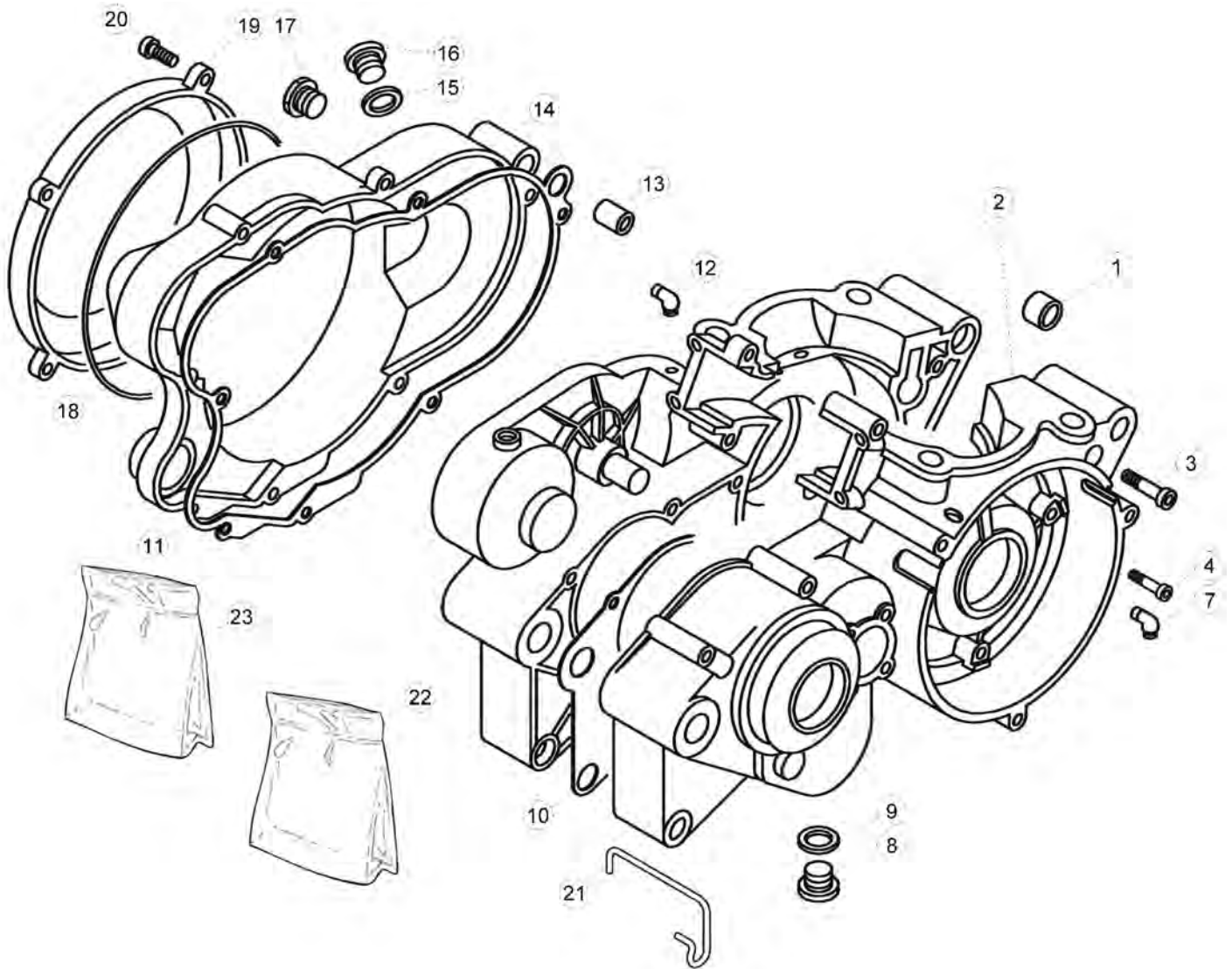

Tav.1A

Pos Loc Ps Pos	Numero Number Numéro Nummer	Q.tà Q.ty Q.té M.ge C.ad	Nota Note Note Nota Anm.	Descrizione	Description	Dé signation	Beschreibung	Descrìpziò n
1	16.41500.000	2		Grano di riferimento	Dowel	Repère	Passtift	Centraje
2	007.01.400.80.00	1	125cc	Carter completo	Crankcase assy	Carter comp.	Kurbelwellengehä use komp.	Cá rter comp.
2	007.01.410.80.00	1	200cc	Carter completo	Crankcase assy	Carter comp.	Kurbelwellengehä use komp.	Cá rter comp.
2	007.01.415.80.00	1	250-300cc	Carter completo	Crankcase assy	Carter comp.	Kurbelwellengehä use komp.	Cá rter comp.
3	31.59010.000	11		Vite 6x50	Screw 6x50	Vis 6x50	Schraube 6x50	Tornillo 6x50
4	31.29910.000	7	125-200cc	Vite 5x12	Screw 5x12	Vis 5x12	Schraube 5x12	Tornillo 5x12
4	31.29910.000	3	250-300cc	Vite 5x12	Screw 5x12	Vis 5x12	Schraube 5x12	Tornillo 5x12
7	27.23470.000	1		Raccordo per sfiato	Breather pipe	Raccord pour vidange	Entlü ftungsrohranschluß	Racor para ventilació n
8	29.00451.000	1		Tappo scarico olio con calamita	Oil drain plug with magnet	Bouchon vidange huile avec aimant	Verschluß für Ölablaß mit Magnet	Tapó n vaciado aceite con imán
9	16.53600.000	1		Guarnizione 16x22,5x1	Packing 16x22,5x1	Joint 16x22,5x1	Dichtung 16x22,5x1	Junta 16x22,5x1
10	007.01.350.00.00	1		Guarnizione carter	Crankcase gasket	Joint carter	Dichtung Kurbelwellengehä use	Junta cá rter
11	16.71681.000	1		Guarnizione coperchio frizione	Clutch cover gasket	Joint couvercle embrayage	Dichtung Kupplungsabdeckung	Junta tapa embrague
12	27.23470.000	1		Raccordo per sfiato	Breather pipe	Raccord pour vidange	Entlü ftungsrohranschluß	Racor para ventilació n
13	16.37010.000	2		Grano di riferimento 9x15	Dowel 9x15	Repère 9x15	Passtift 9x15	Centraje 9x15
14	12.62664.352	1		Coperchio frizione interno	Clutch cover	Couvercle d' embrayage	Kupplungsdeckel	Tapa embrague
15	16.53600.000	1		Guarnizione 16x22,5x1	Packing 16x22,5x1	Joint 16x22,5x1	Dichtung 16x22,5x1	Junta 16x22,5x1
16	29.10290.000	1		Tappo livello olio	Oil level plug	Bouchon niveau huile	Ölkontrolverschluss	Tapa nivel aceite
17	29.10030.000	1		Tappo carico olio	Oil filling cap	Bouchon rempl. huile	Öleinfüllstö psel	Tapó n intruducció n aceite
18	10.67340.000	1		Anello or	O-Ring	Bague d' étanché ité	O-Ring	Anillo OR
19	12.63114.052	1		Coperchio frizione esterno	Outer clutch cover	Couvercle externe d' embrayage	Ä ußerer Kupplungsdeckel	Tapa exterior embrague
20	31.34510.000	7		Vite t.c.c.e. M6x20	Screw t.c.c.e. M6x20	Vis t.c.c.e. M6x20	Schraube t.c.c.e. M6x20	Tornillo t.c.c.e. M6x20
21	25.24584.000	1		Passacavo tubi sfiato	Breather pipes grommet	Passe-câ ble tuyaux ré niflard	Kabeldurchgang Entlü ftungsleitungen	Pasacables tubos respiraderos
22	007.45.624.82.00	1	125cc	Serie guarnizioni	Set of gaskets	Jeu de joints	Dichtungssatz	Juego de juntas
22	007.45.625.82.00	1	200cc	Serie guarnizioni	Set of gaskets	Jeu de joints	Dichtungssatz	Juego de juntas
22	007.45.626.82.00	1	250cc	Serie guarnizioni	Set of gaskets	Jeu de joints	Dichtungssatz	Juego de juntas
22	007.45.070.80.00	1	300cc	Serie guarnizioni	Set of gaskets	Jeu de joints	Dichtungssatz	Juego de juntas
23	28.06872.800	1		Serie paraoli	Oil seal set	Kits joints d' huile	Dichtringsatz	Juego retenes

Tav.02

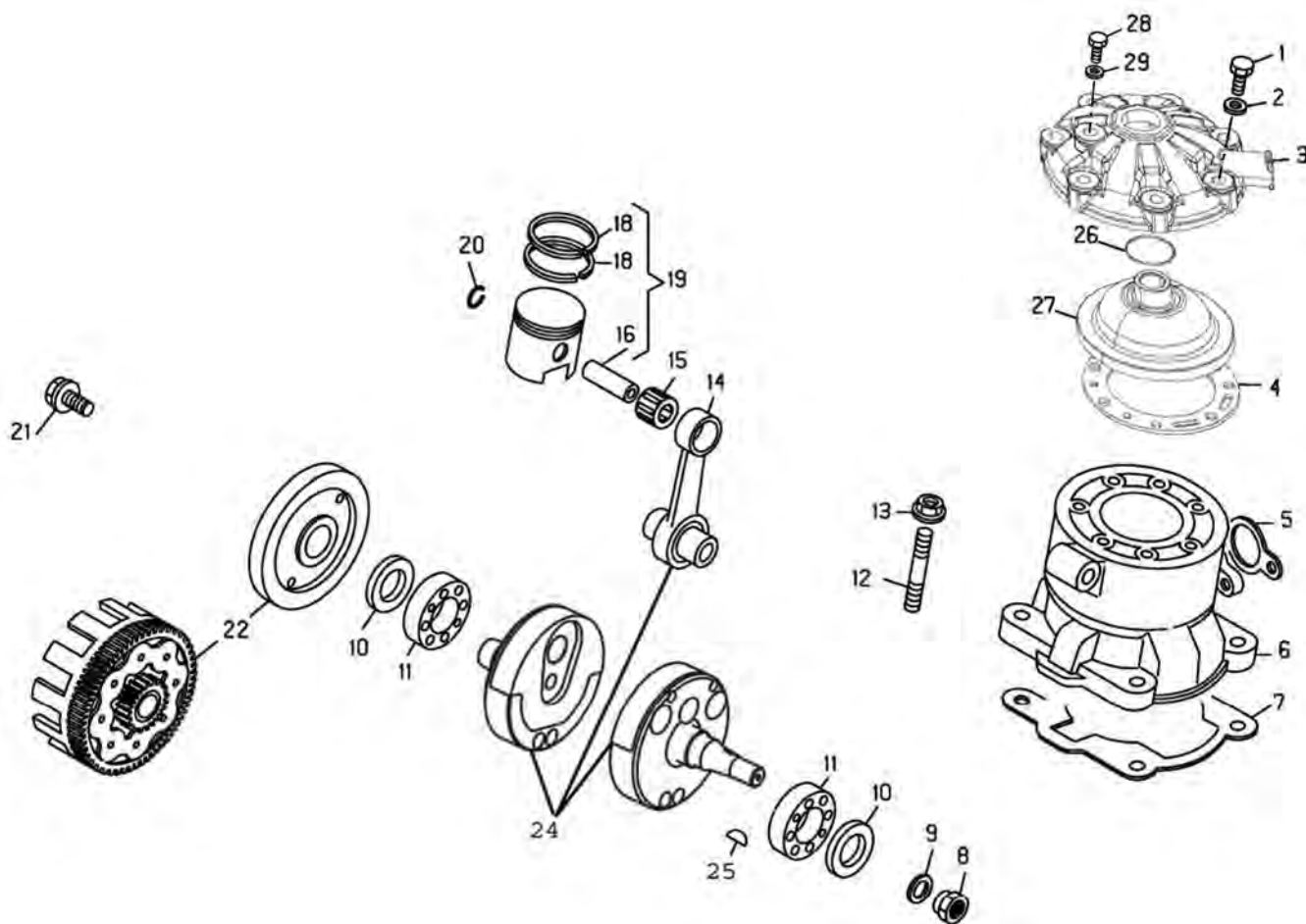

Tav.02

Pos Loc Pos Ps Pos	Numero Number Numéro Número Nummer	Q.tà Q.ty Q.té M.ge C.ad	Nota Note Note Nota Anm.	Descrizione	Description	Dé signation	Beschreibung	Descrìpziò n
1	11.52429.000	7		Bullone speciale 7x31	Special bolt 7x31	Boulon spéciale 7x31	Spezialschraube 7x31	Tornillo especial 7x31
2	27.45100.000	7		Rondella in rame 7x12x0,5	Copper washer 7x12x0,5	Rondelle en cuivre 7x12x0,5	Kupfer U.Scheibe 7x12x0,5	Arandela de cobre 7x12x0,5
3	007.11.009.00.00	1		Calotta protezione testa	Head mounting cap	Capuchon protection culasse	Schutzkappe Zylinderkopf	Capuerza de protecciòn
4	007.11.010.00.00	1	125cc	Guarnizione testa	Head gasket	Garniture tête	Dichtung Kopf	Junta culata
4	16.67206.000	1	200cc	Guarnizione testa	Head gasket	Garniture tête	Dichtung Kopf	Junta culata
4	16.67204.000	1	250cc	Guarnizione testa	Head gasket	Garniture tête	Dichtung Kopf	Junta culata
4	007.11.016.00.00	1	300cc	Guarnizione testa	Head gasket	Garniture cylindre tête	Dichtung Kopf	Junta culata
5	16.80700.000	1		Guarnizione scarico	Exhaust manifold gasket	Joint coll. Ech.	Dichtung Abgaskrü mmer	Junta colector de escape
6	007.11.013.00.0A	1	125cc	Cilindro - Sel. A	Cylinder - Sel. A	Cylindre - Sé l. A	Zylinder - Auswahl A	Cilindro - Sel. A
6	007.11.013.00.0B	1	125cc	Cilindro - Sel. B	Cylinder - Sel. B	Cylindre - Sé l. B	Zylinder - Auswahl B	Cilindro - Sel. B
6	007.11.013.00.0C	1	125cc	Cilindro - Sel. C	Cylinder - Sel. C	Cylindre - Sé l. C	Zylinder - Auswahl C	Cilindro - Sel. C
6	032.11.011.00.0A	1	200cc	Cilindro - Sel. A	Cylinder - Sel. A	Cylindre - Sé l. A	Zylinder - Auswahl A	Cilindro - Sel. A
6	032.11.011.00.0B	1	200cc	Cilindro - Sel. B	Cylinder - Sel. B	Cylindre - Sé l. B	Zylinder - Auswahl B	Cilindro - Sel. B
6	032.11.011.00.0C	1	200cc	Cilindro - Sel. C	Cylinder - Sel. C	Cylindre - Sé l. C	Zylinder - Auswahl C	Cilindro - Sel. C
6	032.11.011.00.0D	1	200cc	Cilindro - Sel. D	Cylinder - Sel. D	Cylindre - Sé l. D	Zylinder - Auswahl D	Cilindro - Sel. D
6	032.11.012.00.0A	1	250cc	Cilindro - Sel. A	Cylinder - Sel. A	Cylindre - Sé l. A	Zylinder - Auswahl A	Cilindro - Sel. A
6	032.11.012.00.0B	1	250cc	Cilindro - Sel. B	Cylinder - Sel. B	Cylindre - Sé l. B	Zylinder - Auswahl B	Cilindro - Sel. B
6	032.11.012.00.0C	1	250cc	Cilindro - Sel. C	Cylinder - Sel. C	Cylindre - Sé l. C	Zylinder - Auswahl C	Cilindro - Sel. C
6	007.11.001.00.0A	1	300cc	Cilindro - Sel. A	Cylinder - Sel. A	Cylindre - Sé l. A	Zylinder - Auswahl A	Cilindro - Sel. A
6	007.11.001.00.0B	1	300cc	Cilindro - Sel. B	Cylinder - Sel. B	Cylindre - Sé l. B	Zylinder - Auswahl B	Cilindro - Sel. B
6	007.11.001.00.0C	1	300cc	Cilindro - Sel. C	Cylinder - Sel. C	Cylindre - Sé l. C	Zylinder - Auswahl C	Cilindro - Sel. C
7	16.61761.020	1	125-200cc	Guarnizione cilindro 0,2mm	Cylinder gasket 0,2mm	Garniture cylindre 0,2mm	Dichtung Zylinder 0,2mm	Junta cilindro 0,2mm
7	16.61761.030	1	125-200cc	Guarnizione cilindro 0,3mm	Cylinder gasket 0,3mm	Garniture cylindre 0,3mm	Dichtung Zylinder 0,3mm	Junta cilindro 0,3mm
7	16.61761.000	1		Guarnizione cilindro 0,5mm	Cylinder gasket 0,5mm	Garniture cylindre 0,5mm	Dichtung Zylinder 0,5mm	Junta cilindro 0,5mm
7	16.61761.100	1	250cc GB	Guarnizione cilindro 1mm	Cylinder gasket 1mm	Garniture cylindre 1mm	Dichtung Zylinder 1mm	Junta cilindro 1mm
7	16.61761.100	1	250cc	Guarnizione cilindro 1mm	Cylinder gasket 1mm	Garniture cylindre 1mm	Dichtung Zylinder 1mm	Junta cilindro 1mm
8	13.27115.000	1	125-200cc	Dado speciale 16x1,25	Special nut 16x1,25	Ecrou spéciale 16x1,25	Spezialmutter 16x1,25	Tuerca especial 16x1,25
8	13.22090.000	1	250-300cc	Dado speciale M14x1,5 ch 19	Special nut M14x1,5 ch 19	Ecrou spéciale M14x1,5 ch 19	Spezialmutter M14x1,5 ch 19	Tuerca especial M14x1,5 ch 19
9	27.57760.000	1		Rondella speciale	Special washer	Rondelle spéciale	Spezial-Unterlegscheibe	Arandela especial
10	10.64661.000	2		Anello paraolio	Oil seal	Joint d' étanché ité	Ölschutzring	Retén de aceite
11	12.99564.000	2		Cuscinetto	Bearing	Roulement	Lager	Cojinete
12	25.98050.000	4	125cc	Prigioniero 8.41	Stud 8.41	Goujon 8.41	Stiftschraube 8.41	Espá rrago 8.41
12	25.98080.000	4	200-250cc	Prigioniero 8.41	Stud 8.41	Goujon 8.41	Stiftschraube 8.41	Espá rrago 8.41
12	25.98055.000	4	300cc	Prigioniero 8.30	Stud 8.30	Goujon 8.30	Stiftschraube 8.30	Espá rrago 8.30
13	13.17121.000	4		Dado speciale M8	Special nut M8	Ecrou spéciale M8	Spezialmutter M8	Tuerca especial M8
14	007.02.009.80.00	1	125cc	Biella completa	Conn.-rod, assy	Bielle compl.	Pleuel, kompl.	Biela compl.
14	007.02.101.80.00	1	200cc	Biella completa	Conn.-rod, assy	Bielle compl.	Pleuel, kompl.	Biela compl.
14	007.02.102.80.00	1	250-300cc	Biella completa	Conn.-rod, assy	Bielle compl.	Pleuel, kompl.	Biela compl.
15	007.02.053.00.00	1	125cc	Gabbia 15x19x20	Cage 15x19x20	Cage 15x19x20	Lagerkä fig 15x19x20	Jaula 15x19x20
15	16.16710.000	1	250cc	Gabbia	Cage	Cage	Lagerkä fig	Jaula
15	16.16700.000	1	300cc	Gabbia	Cage	Cage	Lagerkä fig	Jaula
16	007.02.042.00.00	1	125cc	Spinotto	Pin	Axe	Zapfen	Eje
16	28.93880.000	1	200cc	Spinotto	Pin	Axe	Zapfen	Eje
16	28.94170.000	1	250cc	Spinotto	Pin	Axe	Zapfen	Eje
16	007.02.046.00.00	1	300cc	Spinotto	Pin	Axe	Zapfen	Eje
18	007.02.041.00.00	1	125cc	Segmento	Compression ring	Segment	Kompressions-Kolbenring	Aro de compresiò n
18	28.51500.000	1	200cc	Segmento	Compression ring	Segment	Kompressions-Kolbenring	Aro de compresiò n
18	28.52205.000	1	250cc	Segmento	Compression ring	Segment	Kompressions-Kolbenring	Aro de compresiò n
18	007.02.047.00.00	1	300cc	Segmento	Compression ring	Segment	Kompressions-Kolbenring	Aro de compresiò n
19	007.02.040.80.0A	1	125cc	Pistone completo - Sel. A	Piston set - Sel. A	Piston compl. - Sé l. A	Kolben, kompl. - Auswahl A	Pistó n, compl. - Sel. A
19	007.02.040.80.0B	1	125cc	Pistone completo - Sel. B	Piston set - Sel. B	Piston compl. - Sé l. B	Kolben, kompl. - Auswahl B	Pistó n, compl. - Sel. B
19	007.02.040.80.0C	1	125cc	Pistone completo - Sel. C	Piston set - Sel. C	Piston compl. - Sé l. C	Kolben, kompl. - Auswahl C	Pistó n, compl. - Sel. C
19	007.02.033.82.0A	1	200cc	Pistone completo - Sel. A	Piston set - Sel. A	Piston compl. - Sé l. A	Kolben, kompl. - Auswahl A	Pistó n, compl. - Sel. A
19	007.02.033.82.0B	1	200cc	Pistone completo - Sel. B	Piston set - Sel. B	Piston compl. - Sé l. B	Kolben, kompl. - Auswahl B	Pistó n, compl. - Sel. B
19	007.02.033.82.0C	1	200cc	Pistone completo - Sel. C	Piston set - Sel. C	Piston compl. - Sé l. C	Kolben, kompl. - Auswahl C	Pistó n, compl. - Sel. C
19	007.02.032.80.0A	1	250cc	Pistone completo - Sel. A	Piston set - Sel. A	Piston compl. - Sé l. A	Kolben, kompl. - Auswahl A	Pistó n, compl. - Sel. A
19	007.02.032.80.0B	1	250cc	Pistone completo - Sel. B	Piston set - Sel. B	Piston compl. - Sé l. B	Kolben, kompl. - Auswahl B	Pistó n, compl. - Sel. B
19	007.02.032.80.0C	1	250cc	Pistone completo - Sel. C	Piston set - Sel. C	Piston compl. - Sé l. C	Kolben, kompl. - Auswahl C	Pistó n, compl. - Sel. C
19	007.02.045.80.0A	1	300cc	Pistone completo - Sel. A	Piston set - Sel. A	Piston compl. - Sé l. A	Kolben, kompl. - Auswahl A	Pistó n, compl. - Sel. A
19	007.02.045.80.0B	1	300cc	Pistone completo - Sel. B	Piston set - Sel. B	Piston compl. - Sé l. B	Kolben, kompl. - Auswahl B	Pistó n, compl. - Sel. B
19	007.02.045.80.0C	1	300cc	Pistone completo - Sel. C	Piston set - Sel. C	Piston compl. - Sé l. C	Kolben, kompl. - Auswahl C	Pistó n, compl. - Sel. C
20	007.02.044.00.00	2	125cc	Anello ferma spinotto	Piston pin lock ring	Bague de serrage goujon	Bolzenfeststellring	Anillo sujeta pasador
20	10.42580.000	2	200cc	Anello ferma spinotto	Piston pin lock ring	Bague de serrage goujon	Bolzenfeststellring	Anillo sujeta pasador

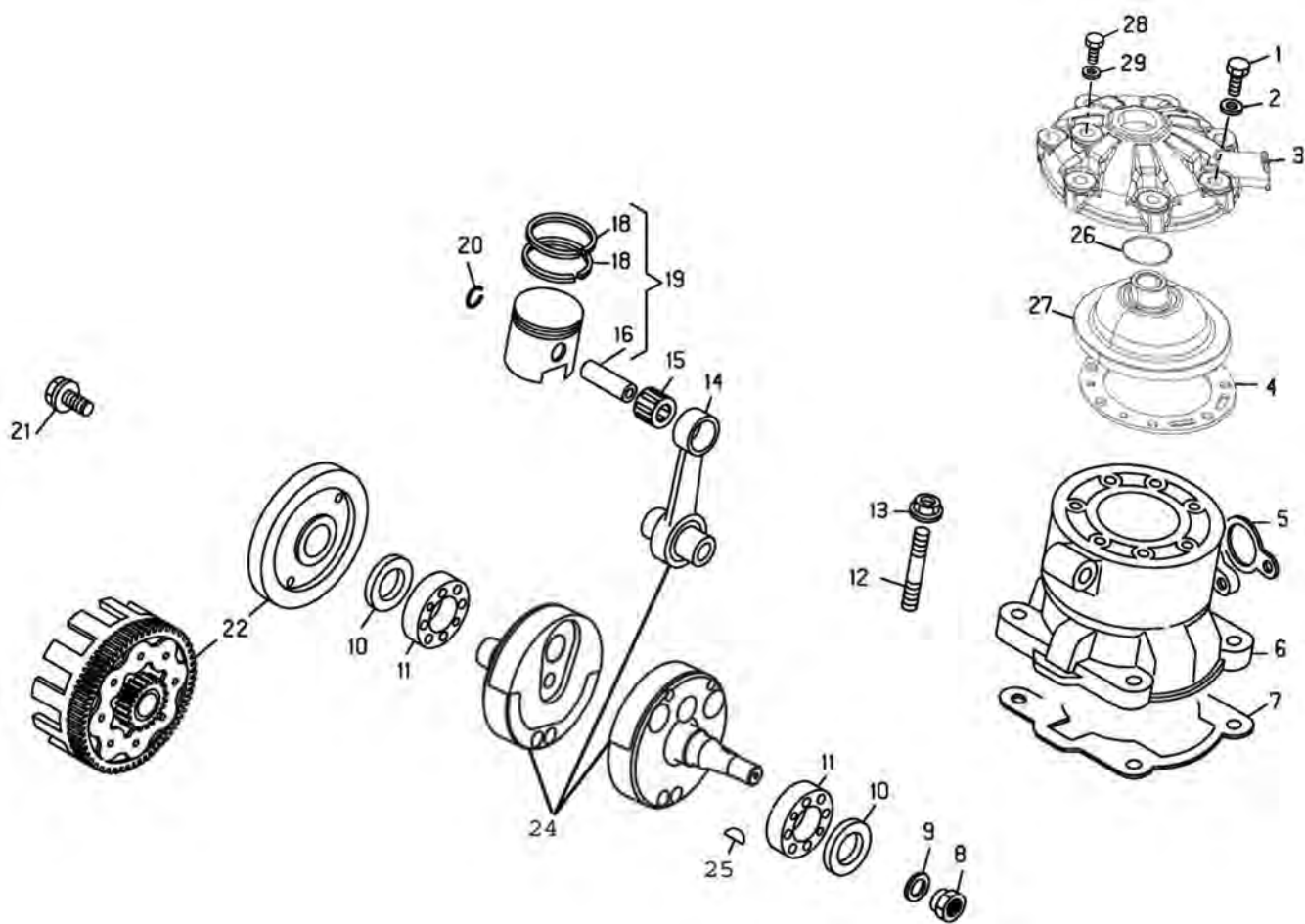

Tav.02

Pos Loc Ps Pos	Numero Number Numéro Nummer	Q.tà Q.ty Q.té M.ge C.ad	Nota Note Nota Anm.	Descrizione	Description	Dé signation	Beschreibung	Descrìpçìo n
20	10.42600.000	2	250-300cc	Anello ferma spinotto	Piston pin lock ring	Bague de serrage goujon	Bolzenfeststellig	Anillo sujeta pasador
21	11.64100.000	1		Bullone speciale	Special bolt	Boulon spéciale	Spezialschraube	Tornillo especial
22	007.03.124.80.00	1	125-200cc	Trasmissione primaria/Frizione	Primary drive /Clutch	Transmission principale/	Hauptantrieb/Kupplung	Transmisión primaria/
22	007.03.439.80.00	1	250-300cc	Trasmissione primaria/Frizione	Primary drive /Clutch	Transmission principale/Embrayage	Hauptantrieb/Kupplung	Transmisión primaria/embrague
22	007.03.435.80.00	1	250cc GB	Trasmissione primaria/Frizione	Primary drive /Clutch	Transmission principale/Embrayage	Hauptantrieb/Kupplung	Transmisión primaria/embrague
24	007.02.006.80.00	1	125cc	Albero motore	Crankshaft	Vilebrequin	Kurbelwelle	Cigüeñal
24	007.02.094.80.00	1	200cc	Albero motore	Crankshaft	Vilebrequin	Kurbelwelle	Cigüeñal
24	007.02.096.80.00	1	250-300cc	Albero motore	Crankshaft	Vilebrequin	Kurbelwelle	Cigüeñal
25	12.46000.000	1		Chiavetta	Key	Clavette	Keil	Chaveta
26	10.66505.000	1		Anello OR 22.27.2,5 vyton	O-Ring 22.27.2,5 vyton	Bague d' é tanché ité 22.27.2,5 vyton	O-Ring 22.27.2,5 vyton	Anillo OR 22.27.2,5 vyton
27	007.11.215.00.00	1	125cc	Camera di combustione	Compression chamber	Chambre de combustion	Verbrennungsraum	Cámara de combustión
27	12.18630.000	1	200cc	Camera di combustione	Compression chamber	Chambre de combustion	Verbrennungsraum	Cámara de combustión
27	12.18610.000	1	● 250cc	Camera di combustione	Compression chamber	Chambre de combustion	Verbrennungsraum	Cámara de combustión
27	007.11.017.00.00	1	■ 250cc	Camera di combustione	Compression chamber	Chambre de combustion	Verbrennungsraum	Cámara de combustión
27	007.11.017.00.00	1	250cc GB	Camera di combustione	Compression chamber	Chambre de combustion	Verbrennungsraum	Cámara de combustión
27	007.11.216.00.00	1	300cc	Camera di combustione	Compression chamber	Chambre de combustion	Verbrennungsraum	Cámara de combustión
28	11.47018.000	1		Bullone speciale	Special bolt	Boulon spéciale	Spezialschraube	Tornillo especial
29	27.58000.000	1		Rondella	Washer	Rondelle	U.Scheibe	Arandela

da Nr. telaio from frame nr. du châssis n° nur ab Rahmen n. desde chasis n.	fino al Nr. telaio until frame nr. jusqu' au châssis n° bis zum Rahmen n. hasta chasis n.
ZD3T60100F0203351	ZD3T60100F0203999



da Nr. telaio from frame nr. du châssis n° nur ab Rahmen n. desde chasis n.	fino al Nr. telaio until frame nr. jusqu' au châssis n° bis zum Rahmen n. hasta chasis n.
ZD3T60100F0204001	ZD3T60100F0249999

Tav.03

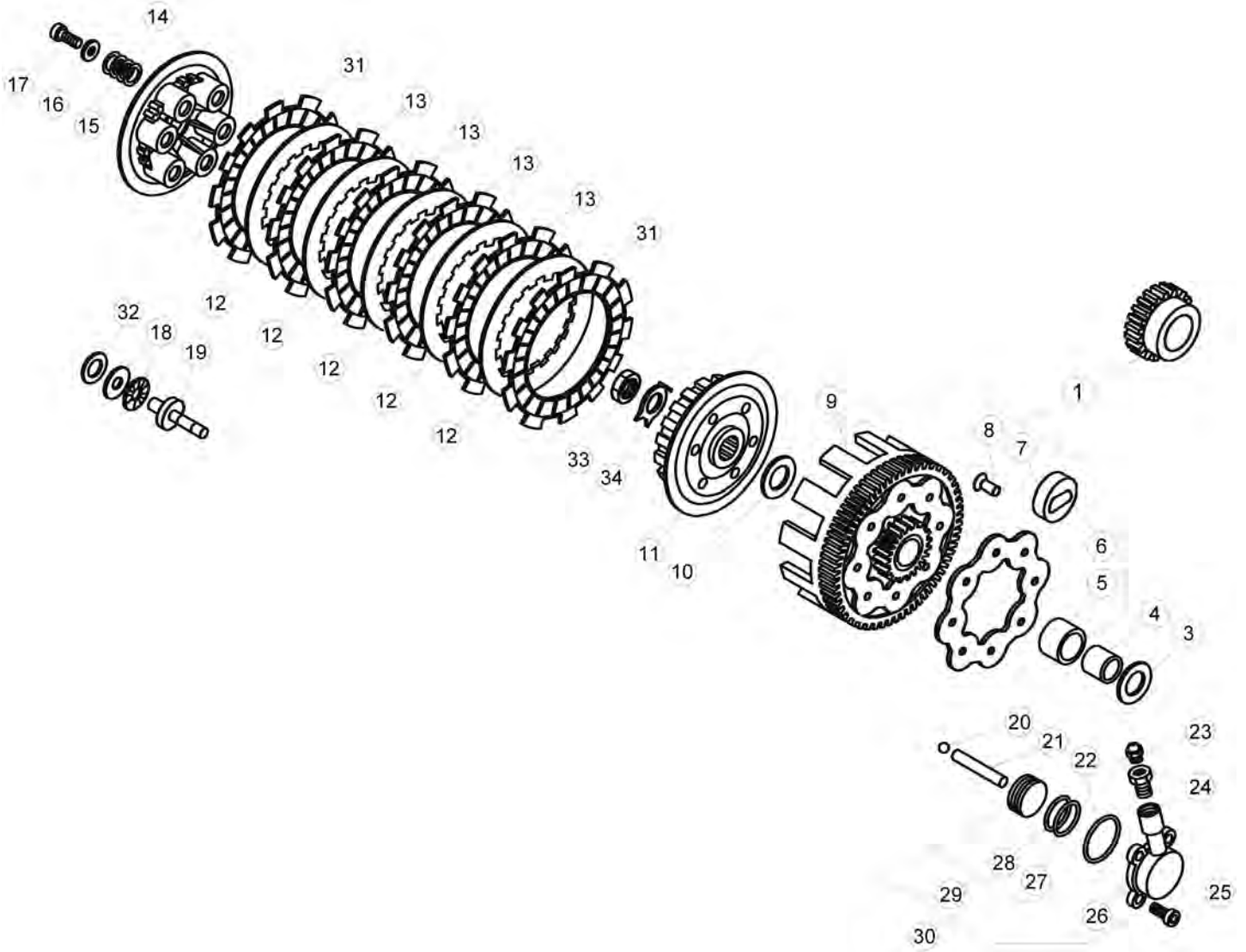

Tav.03

Pos Loc Pos Ps Pos	Numero Number Numéro Nummer	Q.tà Q.ty Q.té M.ge C.ad	Nota Note Note Nota Anm.	Descrizione	Description	Dé signation	Beschreibung	Descrìpziò n
1	007.03.124.80.00	1	125-200cc	Trasmissione primaria/Frizione	Primary drive /Clutch	Transmission principale/Embrayage	Hauptantrieb/Kupplung	Transmisión primaria/embrague
1	007.03.439.80.00	1	250-300cc	Trasmissione primaria/Frizione	Primary drive /Clutch	Transmission principale/Embrayage	Hauptantrieb/Kupplung	Transmisión primaria/embrague
1	007.03.435.80.00	1	250cc GB	Trasmissione primaria/Frizione 300cc GB	Primary drive /Clutch	Transmission principale/Embrayage	Hauptantrieb/Kupplung	Transmisión primaria/embrague
3	27.73480.000	1		Rondella 20x35x1	Washer 20x35x1	Rondelle 20x35x1	U.Scheibe 20x35x1	Arandela 20x35x1
4	11.27130.000	1		Anello interno in acciaio	Inner iron ring	Bague int. en acier	Inner stahl Ring	Anillo int. de acero
5	11.27145.000	1		Boccola PAP	Bush PAP	Moyeu PAP	Büchse PAP	Buje PAP
6	13.42962.000	1		Disco ritegno silent-block	Retaining block, silent plate	Disque de retenue du silentbloc	Rückhaltescheibe silentblock	Disco de retención silent block
7	28.91840.000	1		Silent-block frizione	Clutch silentblock	Silentbloc embrayage	Silentblock Kupplung	Silent-block embrague
8	27.31642.000	8		Ribattino 5x15	Rivet 5x15	Rivet 5x15	Niet 5x15	Remache 5x15
9	12.20782.000	1		Campana frizione	Clutch case	Cloche d'embrayage	Kupplungsglocke	Campana de embr.
10	27.65890.000	1		Rondella speciale	Special washer	Rondelle speciale	Spezial-Unterlegscheibe	Arandela especial
11	007.03.010.00.00	1	125-200cc	Tamburino frizione	Clutch drum	Noix d'embrayage	Kupplungsstrommel	Tambor embrague
11	007.03.011.00.00	1	250-300cc	Tamburino frizione	Clutch drum	Noix d'embrayage	Kupplungsstrommel	Tambor embrague
12	13.38360.000	5		Disco acciaio	Steel plate	Disque lisse	Stahlscheibe	Disco de acero
13	13.43310.000	4		Disco d'attrito	Friction disc	Disque de friction	Reibscheibe	Disco de rozamiento
14	12.29601.000	1		Cappellotto spingidisco	Pressure plate cap	Plateau de pression	Verschlußkappe Scheibendrucker	Tapa plato de presión
15	22.65071.000	6		Molla frizione	Clutch spring	Ressort embr.	Kupplg.feder	Muelle embr.
16	27.42000.000	6	125-200cc	Rondella 6x18	Washer 6x18	Rondelle 6x18	U.Scheibe 6x18	Arandela 6x18
16	27.42010.000	6	250-300cc	Rondella 6x18	Washer 6x18	Rondelle 6x18	U.Scheibe 6x18	Arandela 6x18
17	11.48010.000	6		Bullone 6x16	Bolt 6x16	Boulon 6x16	Bolzen 6x16	Tornillo 6x16
18	16.11370.000	1		Gabbia reggispinta 15x28x2	Thrust bearing cage 15x28x2	Butée à aiguilles 15x28x2	Andruckkäfig 15x28x2	Jaula cojinete de empuje 15x28x2
19	25.60410.000	1		Piattello spingidisco	Spring collar	Godet d'embrayage	Druckteller	Platillo embrague
20	28.90210.000	1		Sfera	Ball	Bille	Kugel	Bola
21	10.88258.000	1		Asta comando frizione	Clutch control rod	Tige de commande embrayage	Kupplungssteuerungsstab	Varilla mando embrague
22	10.66700.000	1		Anello OR 29,32 z1,5	Ring 29,32 z1,5	Bague d'étranchéité 29,32 z1,5	O-Ring 29,32 z1,5	Anillo OR 29,32 z1,5
23	28.91050.000	1		Tappo sfiato	Breather plug	Bouchon reniflard	Verschluß Entlüfter	Tapón respiradero
24	11.65030.000	1		Vite di sfiato	Drain screw	Vis de vidange	Entlüfterschraube	Tornillo de ventilación
25	31.29910.000	4		Vite 5x12	Screw 5x12	Vis 5x12	Schraube 5x12	Tornillo 5x12
26	12.91890.957	1		Corpo pompa ø28	Pump plunger cylinder ø28	Cylindre de plongeur de pompe ø28	Pumpengehäuse ø28	Cuepo bomba ø28
27	10.66520.000	1		Anello OR 23,52X1,78	Ring 23,52X1,78	Bague d'étranchéité 23,52X1,78	O-Ring 23,52X1,78	Anillo OR 23,52X1,78
28	10.66510.000	1		Anello OR 21,89X2,62	Ring 21,89X2,62	Bague d'étranchéité 21,89X2,62	O-Ring 21,89X2,62	Anillo OR 21,89X2,62
29	25.86930.000	1		Pistone completo	Piston set	Piston compl.	Kolben, kompl.	Pistón, compl.
30	12.91890.057	1		Corpo pompa con pistone	Clutch slave cylinder w/piston	Corps de pompe avec piston	Gehäuse kupplungspumpe mit kolben	Protector con piston de la bomba
31	13.43312.000	2		Disco conduttore	Driving plate	Disque plate	Kupplungs - Streibscheibe	Disco conductor
32	27.64500.080	1		Rondella spessore 15x25x0.8	Shim 15x25x0.8	Rondelle entretoise 15x25x0.8	Ausgleichscheibe 15x25x0.8	Arandela suplemento 15x25x0.8
33	13.28950.000	1		Dado speciale 14x1,25x6	Special nut 14x1,25x6	Ecrou speciale 14x1,25x6	Spezialmutter 14x1,25x6	Tuerca especial 14x1,25x6
34	27.74760.000	1		Rondella fermadado 14	Nut tab washer 14	Rondelle serre-écrou 14	Scheibe mutternsicherung 14	Arandela de empuje tuerca 14

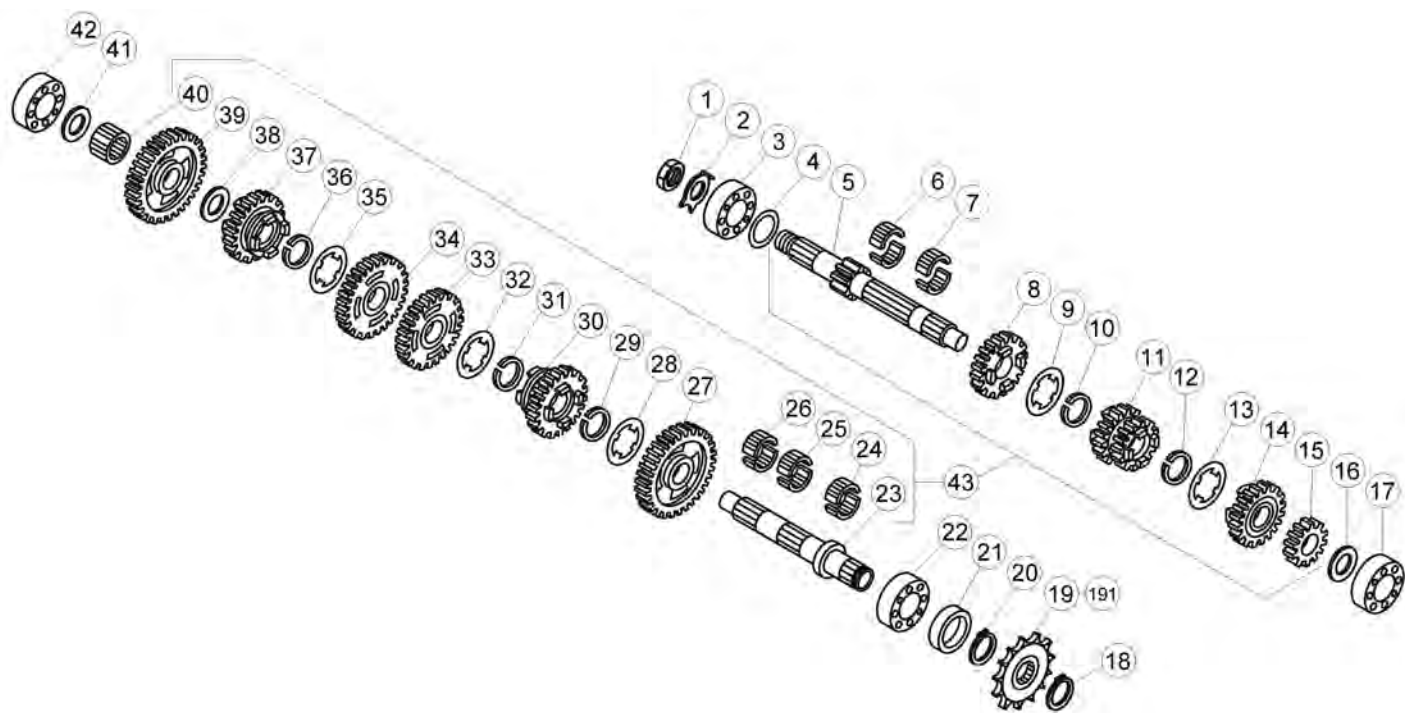

Tav.04

Pos Loc Pos Ps Pos	Numero Number Numéro Nummer	Q.tà Q.ty Q.té M.ge C.ad	Nota Note Note Nota Anm.	Descrizione	Description	Dé signation	Beschreibung	Descrìpziò n
1	13.28950.000	1		Dado speciale 14x1,25x6	Special nut 14x1,25x6	Ecrou spéciale 14x1,25x6	Spezialmutter 14x1,25x6	Tuerca especial 14x1,25x6
2	27.74760.000	1		Rondella fermadado 14	Nut tab washer 14	Rondelle serre-écrou 14	Scheibe mutternsicherung 14	Arandela de empuje tuerca 14
3	12.98980.000	1		Cuscinetto 20x52x15	Bearing 20x52x15	Roulement 20x52x15	Lager 20x52x15	Cojinete 20x52x15
4	27.73630.000	1		Rondella spessoramento 20x30x0,5	Spacer washer 20x30x0,5	Entretoise 20x30x0,5	Distanzscheibe 20x30x0,5	Arandela distanciadora 20x30x0,5
5	10.23373.800	1		Albero primario	Mainshaft	Arbre primaire	Hauptwelle	Arbol primario
6	16.14870.000	1		Gabbia 16x21x10	Cage 16x21x10	Cage 16x21x10	Lagerkäfig 16x21x10	Jaula 16x21x10
7	16.14870.000	1		Gabbia 16x21x10	Cage 16x21x10	Cage 16x21x10	Lagerkäfig 16x21x10	Jaula 16x21x10
8	007.04.102.00.00	1		Ingranaggio 5vp	Gear 5vp	Engrenage 5vp	Zahnrad 5vp	Engranaje 5vp
9	27.73860.000	1		Rondella scanalata	Splined washer	Rondelle rainurée	Schlitzscheibe	Arandela con ranura
10	28.25450.000	1		Seeger 19sw	Circlip 19sw	Circlip 19sw	Seeger 19sw	Seeger 19sw
11	007.04.101.00.00	1		Ingranaggio 3/4VP	Gear 3/4VP	Engrenage 3/4VP	Zahnrad 3/4VP	Engranaje 3/4VP
12	28.25450.000	1		Seeger 19sw	Circlip 19sw	Circlip 19sw	Seeger 19sw	Seeger 19sw
13	27.73860.000	1		Rondella scanalata	Splined washer	Rondelle rainurée	Schlitzscheibe	Arandela con ranura
14	007.04.106.00.00	1		Ingranaggio 6VP	Gear 6VP	Engrenage 6VP	Zahnrad 6VP	Engranaje 6VP
15	18.32210.800	1		Ingranaggio 2VP	Gear 2VP	Engrenage 2VP	Zahnrad 2VP	Engranaje 2VP
16	27.64500.050	1		Rondella spess. 15x25x0,5	Washer 15x25x0,5	Rondelle épaisseur 15x25x0,5	Scheibe 15x25x0,5	Arandela 15x25x0,5
17	12.94000.000	1		Cuscinetto 15x35x11	Bearing 15x35x11	Roulement 15x35x11	Lager 15x35x11	Cojinete 15x35x11
18	28.25400.000	1		Seeger 20e	Circlip 20e	Circlip 20e	Seeger 20e	Seeger 20e
19	25.60850.000	1	125cc	Pignone Z.9	Pinion Z.9	Pignon Z.9	Ritzel Z.9	Piñón Z.9
19	25.60841.000	1	125cc	Pignone Z.13	Pinion Z.13	Pignon Z.13	Ritzel Z.13	Piñón Z.13
19	25.60843.000	1	200-250-300cc	Pignone Z.11	Pinion Z.11	Pignon Z.11	Ritzel Z.11	Piñón Z.11
19.1	001.04.010.00.00	1	250-300cc	Pignone Z.10	Pinion Z.10	Pignon Z.10	Ritzel Z.10	Piñón Z.11
20	28.25400.000	1		Seeger 20e	Circlip 20e	Circlip 20e	Seeger 20e	Seeger 20e
21	10.64050.000	1		Anello paraolio 20x37x7	Oil seal 20x37x7	Joint d'étanchéité 20x37x7	Ölschutzring 20x37x7	Retén de aceite 20x37x7
22	12.98980.000	1		Cuscinetto 20x52x15	Bearing 20x52x15	Roulement 20x52x15	Lager 20x52x15	Cojinete 20x52x15
23	10.29371.800	1		Albero secondario	Counter shaft	Arbre secondaire	Nebengetriebwelle	Eje secundario
24	16.16580.000	1		Gabbia 18x22x10	Cage 18x22x10	Cage 18x22x10	Lagerkäfig 18x22x10	Jaula 18x22x10
25	16.16580.000	1		Gabbia 18x22x10	Cage 18x22x10	Cage 18x22x10	Lagerkäfig 18x22x10	Jaula 18x22x10
26	16.16580.000	1		Gabbia 18x22x10	Cage 18x22x10	Cage 18x22x10	Lagerkäfig 18x22x10	Jaula 18x22x10
27	007.04.108.00.00	1		Ingranaggio 2VS	Gear 2VS	Engrenage 2VS	Zahnrad 2VS	Engranaje 2VS
28	007.04.110.00.00	1		Rondella scanalata	Splined washer	Rondelle rainurée	Schlitzscheibe	Arandela con ranura
29	28.25460.000	1		Seeger 20SW	Circlip 20SW	Circlip 20SW	Seeger 20SW	Seeger 20SW
30	007.04.109.00.00	1		Ingranaggio 6VS	Gear 6VS	Engrenage 6VS	Zahnrad 6VS	Engranaje 6VS
31	28.25460.000	1		Seeger 20SW	Circlip 20SW	Circlip 20SW	Seeger 20SW	Seeger 20SW
32	27.73870.000	1		Rondella scanalata	Splined washer	Rondelle rainurée	Schlitzscheibe	Arandela con ranura
33	007.04.103.00.00	1		Ingranaggio 3VS	Gear 3VS	Engrenage 3VS	Zahnrad 3VS	Engranaje 3VS
34	007.04.104.00.00	1		Ingranaggio 4VS	Gear 4VS	Engrenage 4VS	Zahnrad 4VS	Engranaje 4VS
35	27.73870.000	1		Rondella scanalata	Splined washer	Rondelle rainurée	Schlitzscheibe	Arandela con ranura
36	28.25460.000	1		Seeger 20SW	Circlip 20SW	Circlip 20SW	Seeger 20SW	Seeger 20SW
37	007.04.105.00.00	1		Ingranaggio 5VS	Gear 5VS	Engrenage 5VS	Zahnrad 5VS	Engranaje 5VS
38	27.73560.000	1		Rondella spessoramento 18x27x0,8	Spacer washer 18x27x0,8	Entretoise 18x27x0,8	Distanzscheibe 18x27x0,8	Arandela distanciadora 18x27x0,8
39	007.04.107.00.00	1		Ingranaggio 1VS	Gear 1VS	Engrenage 1VS	Zahnrad 1VS	Engranaje 1VS
40	16.16580.000	1		Gabbia 18x22x10	Cage 18x22x10	Cage 18x22x10	Lagerkäfig 18x22x10	Jaula 18x22x10
41	27.64500.050	1		Rondella spess. 15x25x0,5	Washer 15x25x0,5	Rondelle épaisseur 15x25x0,5	Scheibe 15x25x0,5	Arandela 15x25x0,5
42	12.94000.000	1		Cuscinetto 15x35x11	Bearing 15x35x11	Roulement 15x35x11	Lager 15x35x11	Cojinete 15x35x11
43	007.04.100.80.00	1		Cambio	Gear-box	Boîte à vitesses	Schaltung	Cambio

Tav.05

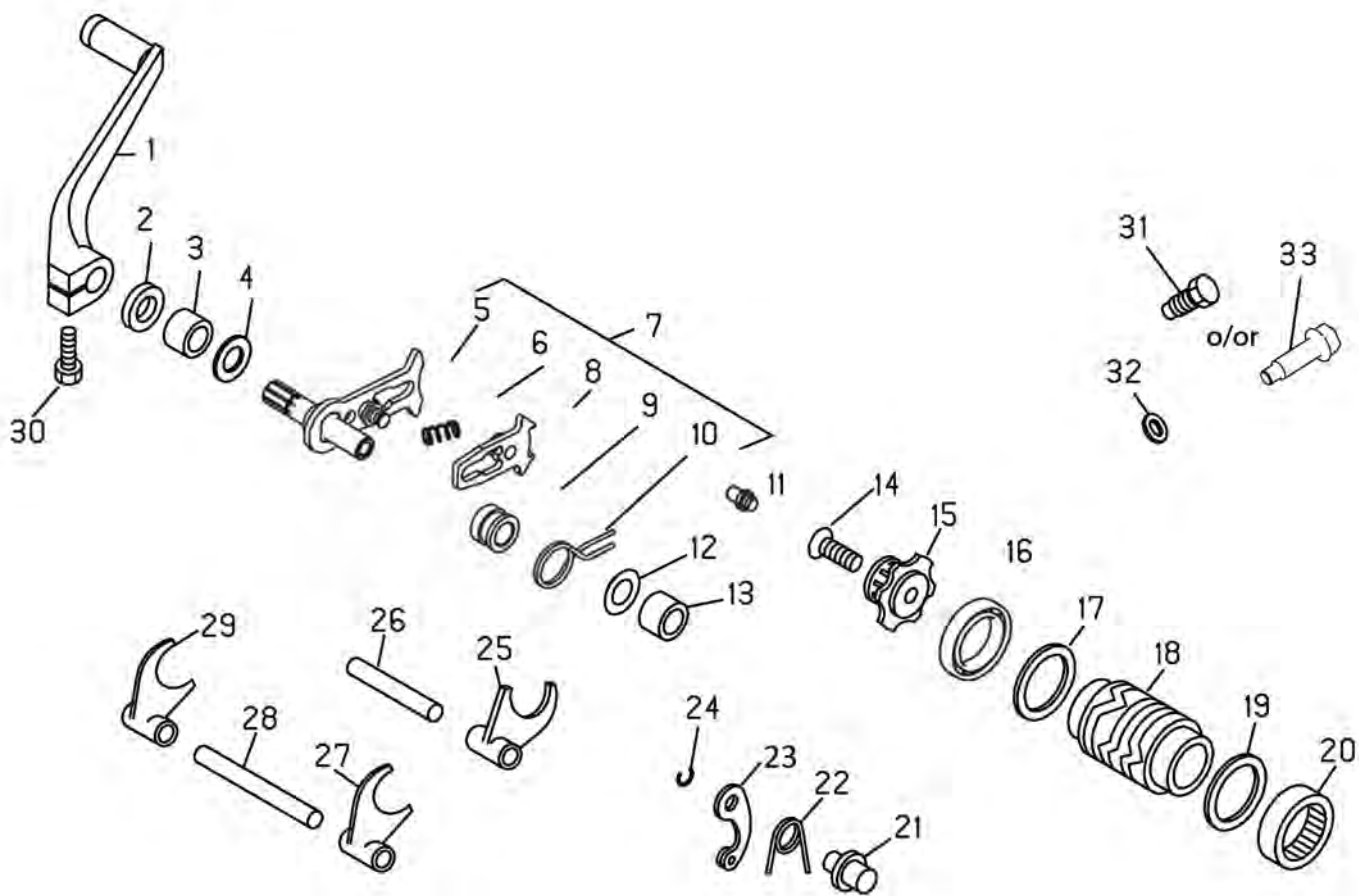

Tav.05

Pos Loc Ps Pos	Numero Number Numéro Nummer	Q.tà Q.ty Q.té M.ge C.ad	Nota Note Note Nota Anm.	Descrizione	Description	Dé signation	Beschreibung	Descrìpziò n
1	21.21150.000	1		Leva comando cambio	Gearshift lever	Levier de vitesse	Schalthebel	Palanca mando cambio
2	10.48000.000	1		Anello paraolio 12x22x5	Oil seal 12x22x5	Joint d' é tanché ité 12x22x5	Ölschutzring 12x22x5	Retén de aceite 12x22x5
3	11.22200.000	1		Boccola a rullini 12x18x12	Roller cage 12x18x12	Cage Aiguille 12x18x12	Rollenkä fig 12x18x12	Jaula rodillos 12x18x12
4	27.60000.000	1		Rondella spessoramento 12x22	Spacer washer 12x22	Entretoise 12x22	Distanzscheibe 12x22	Arandela distanciadora 12x22
5	10.13184.000	1		Albero comando cambio	Gearshift shaft	Arbre de vitesse	Schaltwelle	Eje mando cambio
6	22.68010.000	1		Molla ventaglio	Pawl spring	Ressort é ventail	Schaltfeder	Muelle del abanico
7	10.13184.800	1		Albero cambio compl.	Gear shaft assy.	Arbre Boi te à vitesse compl.	Getriebewelle kpl.	Eje cambio compl.
8	31.20980.800	1		Ventaglio mobile con perno	Movable pawl with pin	Eventail mobile avec pivot	Schaltautomat mit Bolzen	Abanico mó vil con perno
9	13.55255.000	1		Distanziale	Spacer	Entretoise	Distanzstück	Distanciator
10	22.72020.000	1		Molla ritorno comando cambio	Gearchange return spring	Ressort de retour comm. ch.ge vit.	Rückstellfeder schaltung	Muelle de retorno cambio
11	25.45231.000	1		Perno richiamo molla	Return pin, spring	Pivot de rappel ressort	Rückzugzapfen Feder	Perno de retorno muelle
12	27.60000.000	1		Rondella spessoramento 12x22	Spacer washer 12x22	Entretoise 12x22	Distanzscheibe 12x22	Arandela distanciadora 12x22
13	11.22200.000	1		Boccola a rullini 12x18x12	Roller cage 12x18x12	Cage Aiguille 12x18x12	Rollenkä fig 12x18x12	Jaula rodillos 12x18x12
14	31.30510.000	1		Vite 6x30	Screw 6x30	Vis 6x30	Schraube 6x30	Tornillo 6x30
15	12.19101.000	1		Camma arresto marce	Gear Stopper Cam	Came Buté e Vitesses	Gangsperrnocken	Leva Parada Marchas
16	12.99405.000	1		Cuscinetto 25x37x7	Bearing 25x37x7	Roulement 25x37x7	Lager 25x37x7	Cojinete 25x37x7
17	27.73695.050	1		Rondella spessoramento 25x32x0,5	Spacer washer 25x32x0,5	Entretoise 25x32x0,5	Distanzscheibe 25x32x0,5	Arandela distanciadora 25x32x0,5
18	007.05.006.80.00	1	125-250-300cc	Camma	Cam	Came	Nocke	Excéntrica
18	007.05.003.80.00	1	200cc	Camma	Cam	Came	Nocke	Excéntrica
19	27.74250.000	1		Rondella spessoramento 30x40x0,5	Spacer washer 30x40x0,5	Entretoise 30x40x0,5	Distanzscheibe 30x40x0,5	Arandela distanciadora 30x40x0,5
20	11.23400.000	1		Boccola a rullini 30x37x12	Roller cage 30x37x12	Cage Aiguille 30x37x12	Rollenkä fig 30x37x12	Jaula rodillos 30x37x12
21	25.54430.000	1		Perno fiss. Leva	Lever sec. Pin	Pivot fix. Levier	Befestigungstift Hebel	Perno fij. Palanca
22	22.39590.000	1		Molla arresto marce	Gear stop spring	Ressort arrê t vit.	Gangstopffeder	Muelle arresto vel.
23	21.17100.000	1		Leva arresto marce completa	Gear stop lever, assy.	Levier arrê t vit. compl.	Gangstopfhebel kpl.	Palanca arresto vel. comp.
24	28.22700.000	1		Seeger 10E	Circlip 10E	Circlip 10E	Seeger 10E	Seeger 10E
25	15.64590.000	1		Forchetta 28,5	Fork 28,5	Fourchette 28,5	Schaltgabel 28,5	Horquilla 28,5
26	25.51100.000	1		Perno forchetta 10x60	Spindle, fork 10x60	Axe de fourche 10x60	Schaltgabelstift 10x60	Perno de la horquilla 10x60
27	15.64550.000	1		Forchetta 32,5	Fork 32,5	Fourchette 32,5	Schaltgabel 32,5	Horquilla 32,5
28	25.51110.000	1		Perno forchetta 10x103,5	Spindle, fork 10x103,5	Axe de fourche 10x103,5	Schaltgabelstift 10x103,5	Perno de la horquilla 10x103,5
29	15.64570.000	1		Forchetta 34,5	Fork 34,5	Fourchette 34,5	Schaltgabel 34,5	Horquilla 34,5
30	11.49510.000	1		Bullone 6x25	Bolt 6x25	Boulon 6x25	Bolzen 6x25	Tornillo 6x25
31	11.46501.000	1		Bullone M6x10	Bolt M6x10	Boulon M6x10	Bolzen M6x10	Tornillo M6x10
32	27.58000.000	1		Rondella	Washer	Rondelle	U.Scheibe	Arandela
33	31.96826.000	1		Bullone speciale	Special bolt	Boulon spéciale	Spezialschraube	Tornillo especial

Tav.06

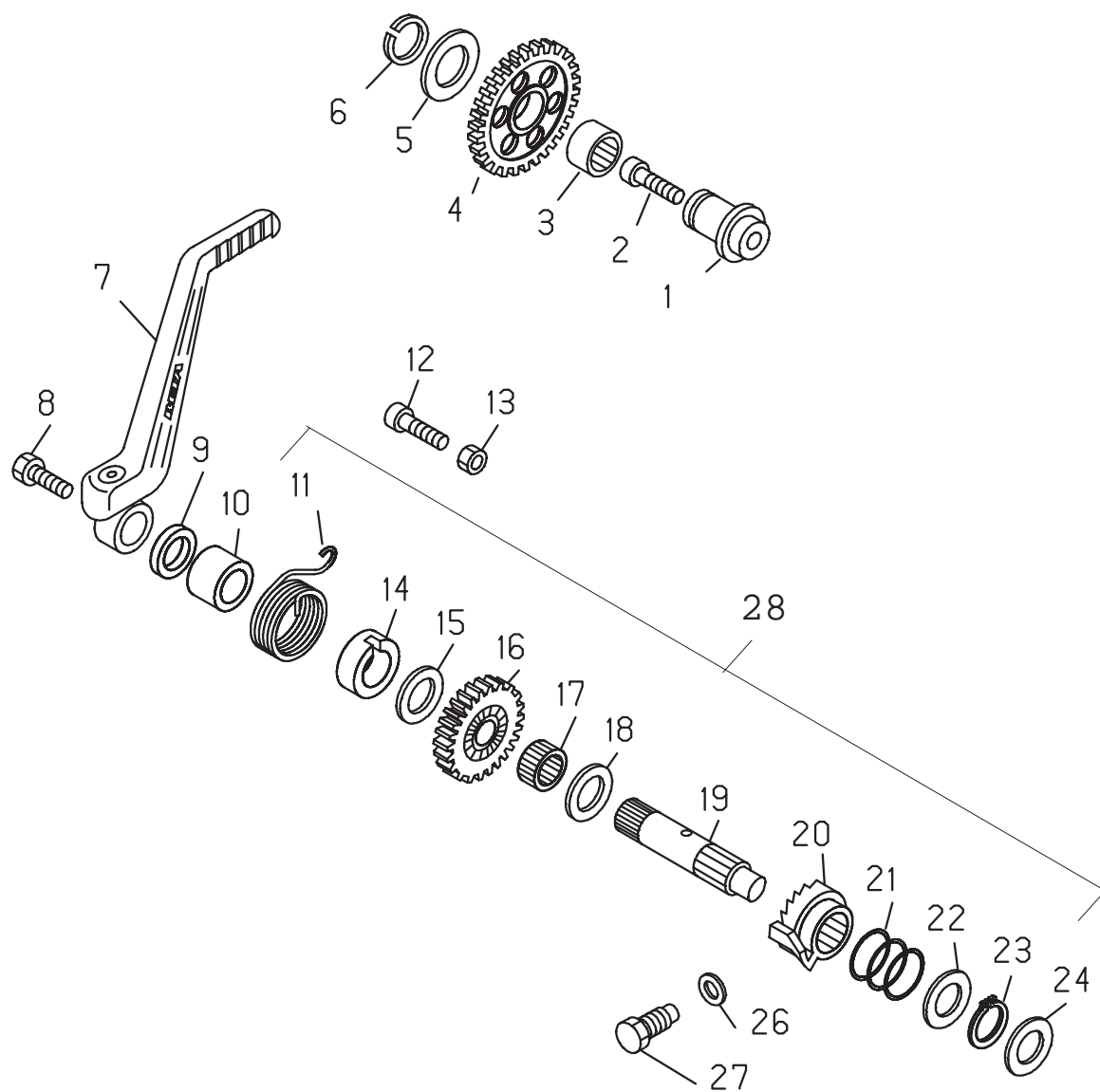

Tav.06

Pos Loc Ps Pos	Numero Number Numéro Número Nummer	Q.tà Q.ty Q.té M.ge C.ad	Nota Note Note Nota Anm.	Descrizione	Description	Dé signation	Beschreibung	Descrìpziò n
1	25.53190.000	1		Perno per ingranaggio rinvio m.m.	Kickstart idler gear shaft	Axe pignon de renvoi de marr.	Stift für Zwischenrad starter	Perno engr. de reenvio arranque
2	31.63890.000	1		Vite 8x20 TCCE	Screw 8x20 TCCE	Vis 8x20 TCCE	Schraube 8x20 TCCE	Tornillo 8x20 TCCE
3	16.16560.000	1		Gabbia 18x22x10	Cage 18x22x10	Cage 18x22x10	Lagerkäfig 18x22x10	Jaula 18x22x10
4	18.67823.000	1		Ingranaggio rinvio m.m.	Kickstart idler gear	Pignon de renvoi de dé marr.	Zwischenrad starter	Engr. de reenvio arranque
5	27.72560.000	1		Rondella spessoramento 18x27	Spacer washer 18x27	Entretoise 18x27	Distanzscheibe 18x27	Arandela distanciadora 18x27
6	28.25300.000	1		Seeger 18E	Circlip 18E	Circlip 18E	Seeger 18E	Seeger 18E
7	007.06.020.80.00	1		Leva messa in moto	Start. lever	Lev. du dé m.	Kickstarterhebel	Palanca de arranque
8	11.54521.000	1		Bullone M8x16	Bolt M8x16	Boulon M8x16	Bolzen M8x16	Tornillo M8x16
9	10.56015.000	1		Anello paraolio 16x22x4	Oil seal 16x22x4	Joint d' é tanché ité 16x22x4	Ölschutzring 16x22x4	Retén de aceite 16x22x4
10	11.31066.000	1		Boccola sinterizzata 16x22x12,5	Bush 16x22x12,5	Bague 16x22x12,5	Sinterbuchse 16x22x12,5	Casquillo 16x22x12,5
11	22.78972.000	1		Molla ritorno leva m.m.	Kickstart lever return spring	Ressort de retour levier de dem.	Rückstellfeder starterhebel	Muelle de retorno palanca arr.
12	31.34510.000	1		Vite t.c.c.e. M6x20	Screw t.c.c.e. M6x20	Vis t.c.c.e. M6x20	Schraube t.c.c.e. M6x20	Tornillo t.c.c.e. M6x20
13	13.11500.000	1		Dado 6x3,5	Nut 6x3,5	Ecrou 6x3,5	Mutter 6x3,5	Tuerca 6x3,5
14	13.55230.000	1		Distanziale	Spacer	Entretoise	Distanzstück	Distanciadór
15	27.67500.040	1		Rondella spessoramento 16x25x0,4	Spacer washer 16x25x0,4	Entretoise 16x25x0,4	Distanzscheibe 16x25x0,4	Arandela distanciadora 16x25x0,4
16	18.14632.800	1		Ingranaggio m.m.	Starting gear	Engrenage du dé marreur	Starterzahnrad	Engranaje puesta en marcha
17	16.14300.000	1		Gabbia 16x20x10	Cage 16x20x10	Cage 16x20x10	Lagerkäfig 16x20x10	Jaula 16x20x10
18	27.67500.040	1		Rondella spessoramento 16x25x0,4	Spacer washer 16x25x0,4	Entretoise 16x25x0,4	Distanzscheibe 16x25x0,4	Arandela distanciadora 16x25x0,4
19	10.15133.800	1		Albero messa in moto	Kickstarter shaft	Arbre du dé marreur	Starterwelle	Eje puesta en marcha
20	22.14111.800	1		Manicotto messa in moto	Kickstart sleeve	Manchon de dé marrage	Muffe starter	Manguito arranque
21	22.36561.000	1		Molla per manicotto	Spring, Kickstart sleeve	Ressort de manchon	Feder für muffe	Muelle para el manguito
22	27.73630.000	1		Rondella spessoramento 20x30x0,5	Spacer washer 20x30x0,5	Entretoise 20x30x0,5	Distanzscheibe 20x30x0,5	Arandela distanciadora 20x30x0,5
23	28.25400.000	1		Seeger 20e	Circlip 20e	Circlip 20e	Seeger 20e	Seeger 20e
24	27.64500.040	1		Rondella spess. 15x25x0,4	Washer 15x25x0,4	Rondelle epaisseur 15x25x0,4	Scheibe 15x25x0,4	Arandela 15x25
26	16.52000.000	1		Guarnizione 12x16x1,5	Packing 12x16x1,5	Joint 12x16x1,5	Dichtung 12x16x1,5	Junta 12x16x1,5
27	11.65501.000	1		Bullone speciale	Special bolt	Boulon spéciale	Spezialschraube	Tornillo especial
28	007.06.015.80.00	1		Messa in moto completa	Kickstart, assy.	Système de demarrage complet	Starter komplett	Arranque completo

Tav.09

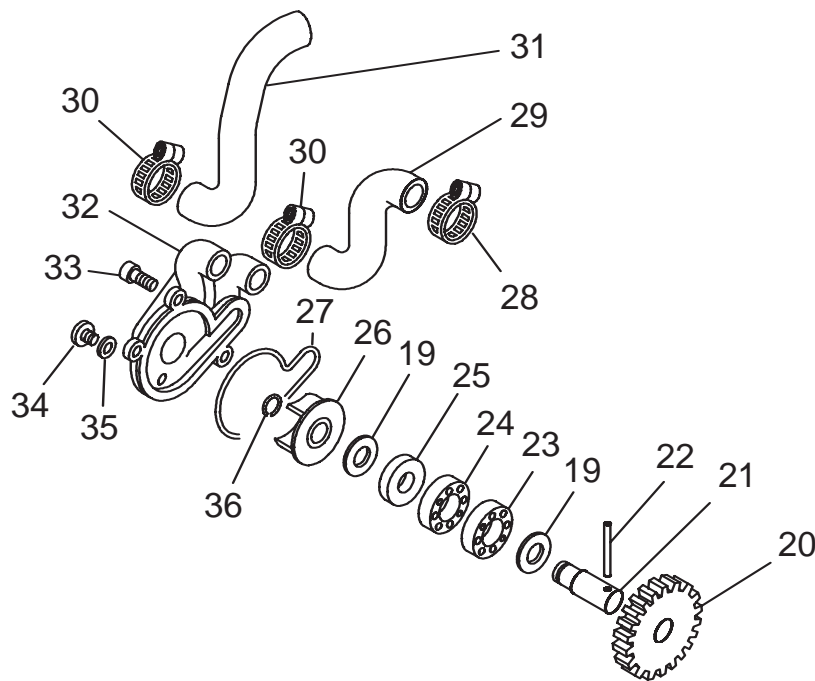

Pos	Numero	Q.tà	Nota	Descrizione	Description	Dé signation	Beschreibung	Descrìpiò n
Loc	Number	Q.ty	Note					
Pos	Numé ro	Q.té	Note					
Ps	Nú mero	M.ge	Nota					
Pos	Nummer	C.ad	Anm.					
19	007.09.010.00.00	2		Rondella inox	Washer inox	Rondelle inox	U.Scheibe inox	Arandela inox
20	18.82641.000	1	125-200cc	Ingranaggio pompa acqua	Water pump gear	Engrenage pompe eau	Zahnrad Wasserpumpe	Engranaje bomba agua
20	007.09.021.00.00	1	250-300cc	Ingranaggio pompa acqua	Water pump gear	Engrenage pompe eau	Zahnrad Wasserpumpe	Engranaje bomba agua
21	10.27740.000	1		Albero pompa acqua	Coolant pump shaft	Arbre de pompe a eau	Wasserpumpenwelle	Eje bomba de agua
22	27.84100.000	1		Rullino 6x12	Roller 6x12	Rouleau 6x12	Rolle 6x12	Rodillo 6x12
23	12.93420.000	1		Cuscinetto 10x22x6	Bearing 10x22x6	Roulement 10x22x6	Lager 10x22x6	Cojinete 10x22x6
24	12.93410.000	1		Cuscinetto	Bearing	Roulement	Lager	Cojinete
25	10.44610.000	1		Paraolio 10x18x4	Oil seal 10x18x4	Pare-huile 10x18x4	Dichtring 10x18x4	Sello de lub. 10x18x4
26	31.21840.000	1		Girante pompa acqua	Water pump fan	Couronne pompe eau	Lü uferrad der Wasserpumpe	Rotor bomba agua
27	10.67360.000	1		Anello or	Ring	Bague d' étanché ité	O-Ring	Anillo OR
28	15.15230.000	1		Fascetta 15x25	Clamp 15x25	Collier 15x25	Schelle 15x25	Abrazadera 15x25
29	29.15863.000	1		Tubo pompa-cilindro	Pump-cylinder hose	Tuyau pompe-cylindre	Pumpen-zylinder leitung	Tubo bomba-cilindro
30	15.15236.000	2		Fascetta autoaggrappante	Clamp	Collier	Schelle	Abrazadera
31	29.15864.000	1		Tubo radiatore-pompa	Radiator-Pump hose	Tuyau radiateur-pompe	Leitung Kü hler-Wasserpumpe	Tubo radiador-bomba
32	12.67931.052	1		Coperchio pompa acqua	Water pump cover	Couvercle pompe à eau	Wasserpumpendeckel	Tapa bomba agua
33	31.30000.000	2		Vite M5x16 TCCE	Screw M5x16 TCCE	Vis M5x16 TCCE	Schraube M5x16 TCCE	Tornillo M5x16 TCCE
34	31.30490.051	1		Vite M6x8 TTLIC	Screw M6x8 TTLIC	Vis M6x8 TTLIC	Schraube M6x8 TTLIC	Tornillo M6x8 TTLIC
35	16.47500.000	1		Guarnizione 6x12x1,5	Packing 6x12x1,5	Joint 6x12x1,5	Dichtung 6x12x1,5	Junta 6x12x1,5
36	28.22660.000	1		Seeger 9E	Seeger 9E	Seeger 9E	Seegerring 9E	Seeger 9E

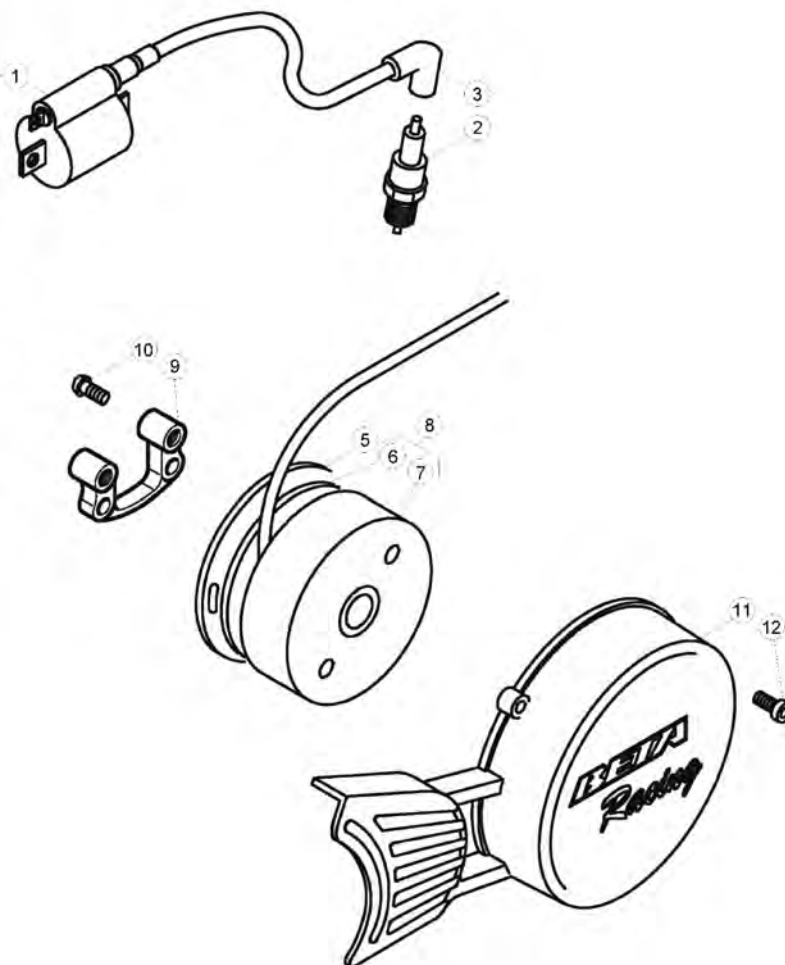

Pos Loc Pos Ps Pos	Numero Number Numé ro Número Nummer	Q.tà Q.ty Q.té M.ge C.ad	Nota Note Note Nota Anm.	Descrizione	Description	Dé signation	Beschreibung	Descrìpiò n
1	11.20682.800	1		Bobina	Coil	Bobine	Spule	Bobina
2	12.25220.000	1		Candela	Spark.plug	Bougie	Zündkerze	Bujia
3	27.13514.000	1		Raccordo candela	Plug fitting	Raccord bougie	Kerzenanschluß	Racor buji a
5	25.60173.000	1		Piastrina statore	Backplate plate	Plateau stator	Ankerplatte plate	Placa del estator
6	007.10.041.00.00	1		Statore	Backplate	Stator	Ankerplatte	Estator
7	007.10.021.00.00	1	125cc	Rotore	Rotor	Rotor	Rotor	Rotor
7	007.10.064.37.00	1	200cc	Rotore	Rotor	Rotor	Rotor	Rotor
8	007.10.050.00.00	1	125cc	Volano completo	Flywheel, assy.	Volant complet	Lichtmaschine kpl.	Volante compl.
8	007.10.063.80.00	1	200cc	Volano completo	Flywheel, assy.	Volant complet	Lichtmaschine kpl.	Volante compl.
9	007.10.022.00.00	1	125cc	Distanziale fissaggio pick-up	Pick-up fastening spacer	Entretoise de fix. pick-up	Befestigungsdistanzstück pick-up	Distanciador fij. pick-up
10	31.30750.000	2	125cc	Vite M6x16	Screw M6x16	Vis M6x16	Schraube M6x16	Tornillo M6x16
11	12.69718.159	1		Coperchio volano	Flywheel cover	Carter volant	Schwungraddeckel	Tapa volante
12	31.34510.000	3		Vite t.c.c.e. M6x20	Screw t.c.c.e M6x20	Vis t.c.c.e M6x20	Schraube t.c.c.e M6x20	Tornillo t.c.c.e M6x20

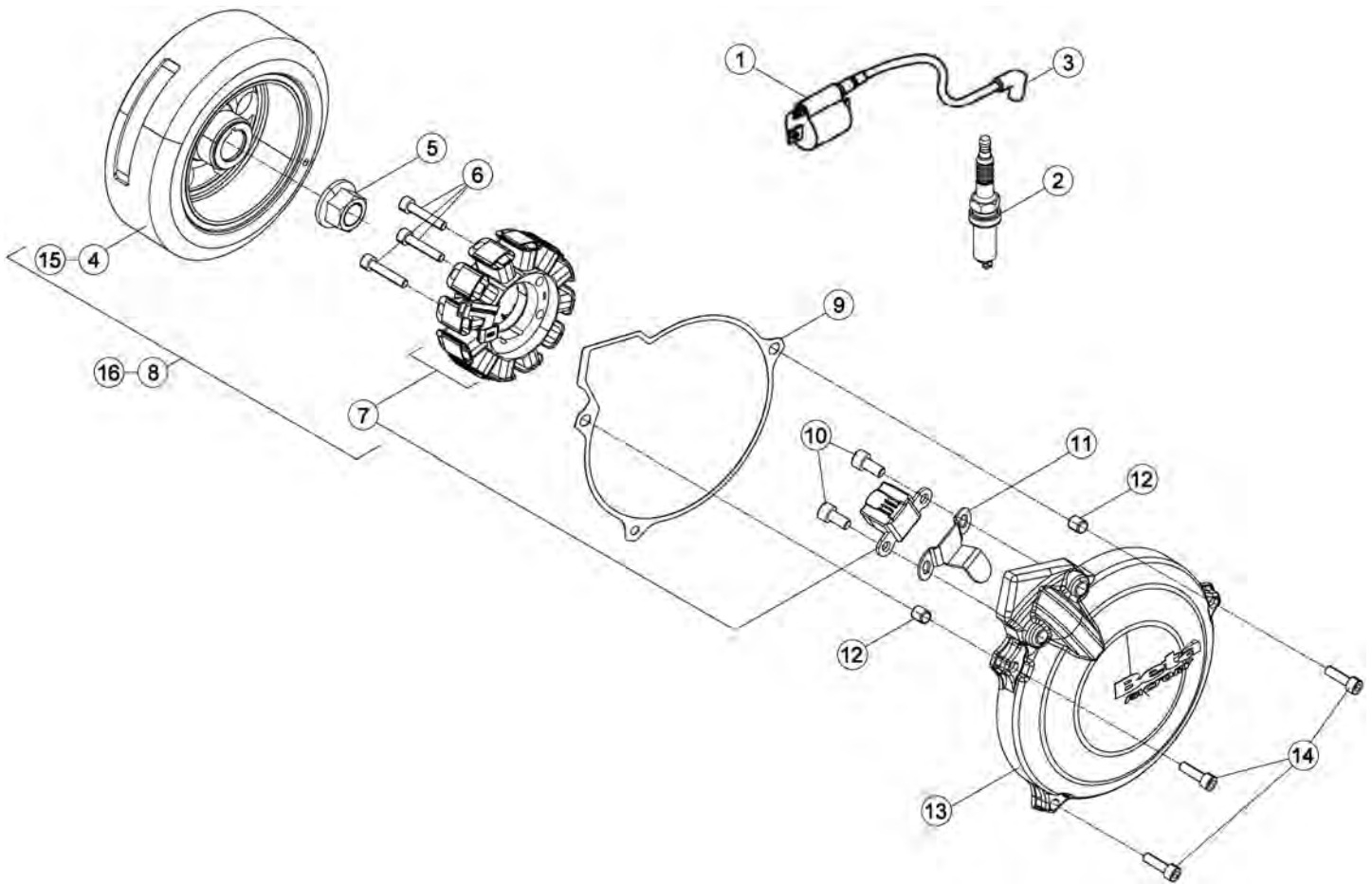

Pos Loc Pos Ps Pos	Numero Number Numé ro Número Nummer	Q.tà Q.ty Q.té M.ge C.ad	Nota Note Note Nota Anm.	Descrizione	Description	Dé signation	Beschreibung	Descrìpcì o n
1	11.20682.800	1		Bobina	Coil	Bobine	Spule	Bobina
2	036.11.000.00.00	1		Candela	Spark plug	Bougie	Zündkerze	Bujia
3	27.13514.000	1		Raccordo candela	Plug fitting	Raccord bougie	Kerzenanschluß	Racor bujia
4	007.10.043.00.00	1		Rotore	Rotor	Rotor	Rotor	Rotor
5	13.22090.000	1		Dado speciale M14x1,5 ch 19	Special nut M14x1,5 ch 19	Ecrou spéciale M14x1,5 ch 19	Spezialmutter M14x1,5 ch 19	Tuerca especial M14x1,5 ch 19
6	31.30020.000	3		Vite M5x25 TCCE	Screw M5x25 TCCE	Vis M5x25 TCCE	Schraube M5x25 TCCE	Tornillo M5x25 TCCE
7	007.10.044.00.00	1		Statore	Backplate	Stator	Ankerplatte	Estator
8	007.10.042.00.00	1		Volano completo	Flywheel, assy.	Volant complet	Lichtmaschine kpl.	Volante compl.
9	007.01.034.00.00	1		Guarnizione coperchio volano	Alternator cover gasket	Garniture couvercle alternateur	Alternatordeckeldichtung	Junta tapa alternador
10	31.31040.000	2		Vite TCEI 6.12	Screw TCEI 6.12	Vis TCEI 6.12	Schraube TCEI 6.12	Tornillo TCEI 6.12
11	007.10.029.50.00	1		Piastrina supporto cavi	Cables sec. plate	Plaque fix. cables		Placa
12	16.36300.000	2		Grano 8x6	Dowel 8x6	Goujon 8x6	Stift 8x6	Clavija 8x6
13	007.01.032.00.52	1		Coperchio volano	Flywheel cover	Cartier volant	Schwungraddeckel	Tapa volante
14	31.38010.000	3		Vite t.c.c.e. M6x25	Screw t.c.c.e M6x25	Vis t.c.c.e M6x25	Schraube t.c.c.e M6x25	Tornillo t.c.c.e M6x25
15	007.10.062.00.00	1	250cc GB- 300cc GB	Rotore	Rotor	Rotor	Rotor	Rotor
16	007.10.061.00.00	1	250cc GB- 300cc GB	Volano completo	Flywheel, assy.	Volant complet	Lichtmaschine kpl.	Volante compl.

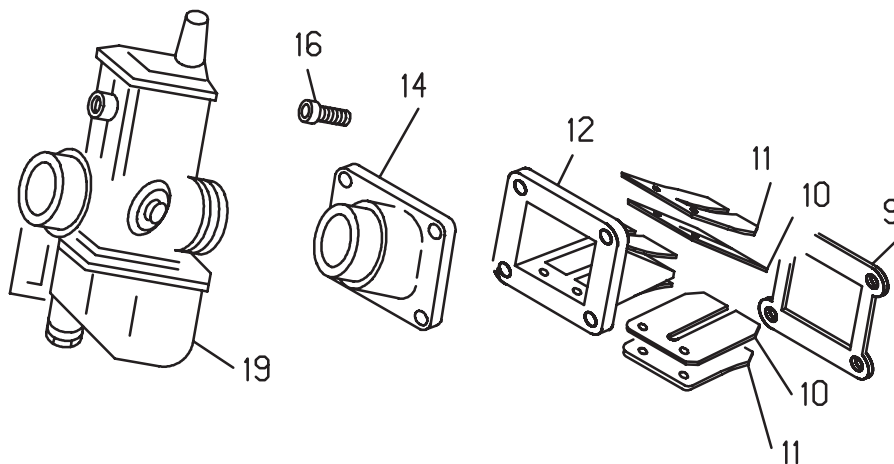

Pos Loc Pos Ps Pos	Numero Number Numéro Número Nummer	Q.tà Q.ty Q.té M.ge C.ad	Nota Note Note Nota Anm.	Descrizione	Description	Dé signation	Beschreibung	Descrìpiòn
9	16.92550.000	1		Guarnizione valvola	Valve gasket	Joint soupape	Ventildichtung	Junta válvula
10	21.15360.000	1		Lamella	Plaque	Lame	Lamellen	Pletina
11	25.59670.000	1		Piastrina	Plate	Plaquette	Plättchen	Placa
12	31.02140.000	1		Valvola completa	Valve, assy.	Soupape complète	Ventil, kompl.	Válvula completa
14	27.23497.000	1	125cc	Raccordo carburatore	Carburettor Union	Raccord Carburateur	Vergaseranschluss	Empalme Carburador
14	27.23496.000	1	200-250 300cc	Raccordo carburatore	Carburettor Union	Raccord Carburateur	Vergaseranschluss	Empalme Carburador
16	31.38010.000	4		Vite t.c.c.e. M6x25	Screw t.c.c.e. M6x25	Vis t.c.c.e. M6x25	Schraube t.c.c.e. M6x25	Tornillo t.c.c.e. M6x25
19	007.12.810.80.00	1	125cc	Carburatore	Carburettor	Carburateur	Vergaser	Carburador
19	007.12.910.80.00	1	200-250 300cc	Carburatore	Carburettor	Carburateur	Vergaser	Carburador

Tav.12B

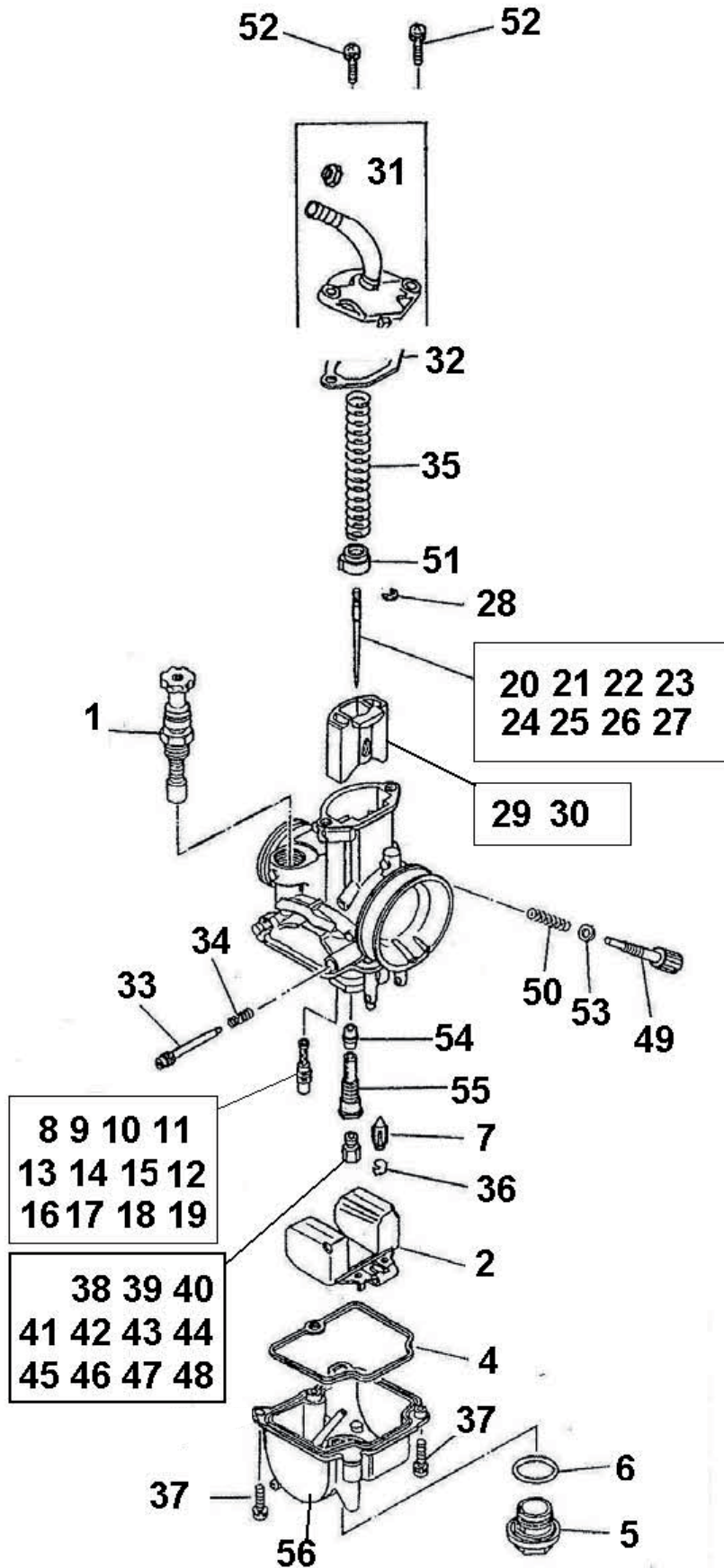

Pos Loc Pos Ps Pos	Numero Number Numé ro Número Nummer	Q.tà Q.ty Q.té M.ge C.ad	Nota Note Nota Anm.	Descrizione	Description	Dé signation	Beschreibung	Descrìpziò n
1	12.55241.000	1		Comando avv. freddo	Starter valve comp	Commande de marrage à froid	Kaltstarteinrichtung	Mando arranque
2	16.17341.000	1		Galleggianti	Float	Flotteurs	Schwimmer	Flotador
4	16.50537.000	1		Guarnizione	Packing	Joint	Dichtung	Junta
5	29.01282.000	1		Tappo	Plug	Bouchon	Verschluß	Tapón
6	10.42667.000	1		Or	o-ring, plug screw	Or	O-Ring	Or
7	28.94288.000	1		Spillo ing. Benzina	Float valve comp	Aiguille essence	Benzinnadel	Aguja gasolina
8	16.42352.000	1		Getto minimo 32	Starter jet 32	Gicleur starter 32	Starterdüse 32	Surtidor starter 32
9	16.42353.000	1		Getto minimo 34	Starter jet 34	Gicleur starter 34	Starterdüse 34	Surtidor starter 34
10	16.42357.000	1		Getto minimo 35	Starter jet 35	Gicleur starter 35	Starterdüse 35	Surtidor starter 35
11	16.42354.000	1		Getto minimo 36	Starter jet 36	Gicleur starter 36	Starterdüse 36	Surtidor starter 36
12	16.42356.000	1		Getto minimo 37	Starter jet 37	Gicleur starter 37	Starterdüse 37	Surtidor starter 37
13	16.42355.000	1		Getto minimo 38	Starter jet 38	Gicleur starter 38	Starterdüse 38	Surtidor starter 38
14	16.42347.000	1		Getto minimo 42	Starter jet 42	Gicleur starter 42	Starterdüse 42	Surtidor starter 42
15	16.42349.000	1		Getto minimo 45	Starter jet 45	Gicleur starter 45	Starterdüse 45	Surtidor starter 45
16	16.42348.000	1		Getto minimo 48	Starter jet 48	Gicleur starter 48	Starterdüse 48	Surtidor starter 48
17	16.42344.000	1		Getto minimo 50	Starter jet 50	Gicleur starter 50	Starterdüse 50	Surtidor starter 50
18	16.42358.000	1		Getto minimo 52	Starter jet 52	Gicleur starter 52	Starterdüse 52	Surtidor starter 52
19	16.42359.000	1		Getto minimo 55	Starter jet 55	Gicleur starter 55	Starterdüse 55	Surtidor starter 55
20	28.94281.000	1		Spillo 46JJJ	Needle 46JJJ	Pointeau 46JJJ	Düsenadel 46JJJ	Aguja 46JJJ
21	28.94282.000	1		Spillo 46JJH	Needle 46JJH	Pointeau 46JJH	Düsenadel 46JJH	Aguja 46JJH
22	28.94283.000	1		Spillo 46JJK	Needle 46JJK	Pointeau 46JJK	Düsenadel 46JJK	Aguja 46JJK
23	28.94284.000	1		Spillo 46JJG	Needle 46JJG	Pointeau 46JJG	Düsenadel 46JJG	Aguja 46JJG
24	28.94285.000	1		Spillo 46JHL	Needle 46JHL	Pointeau 46JHL	Düsenadel 46JHL	Aguja 46JHL
25	28.94286.000	1		Spillo 46JHG	Needle 46JHG	Pointeau 46JHG	Düsenadel 46JHG	Aguja 46JHG
26	28.94287.000	1		Spillo 46JHN	Needle 46JHN	Pointeau 46JHN	Düsenadel 46JHN	Aguja 46JHN
27	28.94269.000	1		Spillo 46LML	Needle 46LML	Pointeau 46LML	Düsenadel 46LML	Aguja 46LML
28	12.54242.000	1		Clip	Clip	Clip	Clip	Clip
29	31.11203.000	1		Valvola gas 4.0	Throttle valve 4.0	Volet de gaz 4.0	Gasschieber 4.0	Válvula gas 4.0
30	31.11202.000	1		Valvola gas 3.5	Throttle valve 3.5	Volet de gaz 3.5	Gasschieber 3.5	Válvula gas 3.5
31	12.56536.000	1		Coperchio carb	Cover	Couvercle carburateur	Vergaserdeckel	Tapa carburador
32	16.50536.000	1		Guarnizione coperchio	Cover gasket	Joint couvercle	Dichtung Deckel	Junta tapa
33	026.12.028.80.00	1		Comando vite reg. aria	Air adjust screw Comp	Commande vis réglage air	Luftinstellschraube	Mando tornillo aire
34	22.39233.000	1		Mola registro aria	Spring, air adjuster	Ressort calage air	Luftinstellfeder	Muelle registro aire
35	22.39231.000	1		Molla	Spring	Ressort	Feder	Muelle
36	12.54243.000	1		Clip	Clip	Clip	Clip	Clip
37	31.63671.000	1		Viti	Screw	Vis	Schraube	Rosca
38	16.42301.000	1		Getto massimo 105	Main jet 105	Gicleur maxi 105	Hauptdüse 105	Surtidor máximo 105
39	16.42303.000	1		Getto massimo 108	Main jet 108	Gicleur maxi 108	Hauptdüse 108	Surtidor máximo 108
40	16.42305.000	1		Getto massimo 110	Main jet 110	Gicleur maxi 110	Hauptdüse 110	Surtidor máximo 110
41	16.42302.000	1		Getto massimo 112	Main jet 112	Gicleur maxi 112	Hauptdüse 112	Surtidor máximo 112
42	16.42306.000	1		Getto massimo 115	Main jet 115	Gicleur maxi 115	Hauptdüse 115	Surtidor máximo 115
43	16.42304.000	1		Getto massimo 118	Main jet 118	Gicleur maxi 118	Hauptdüse 118	Surtidor máximo 118
44	16.42307.000	1		Getto massimo 120	Main jet 120	Gicleur maxi 120	Hauptdüse 120	Surtidor máximo 120
45	16.42308.000	1		Getto massimo 122	Main jet 122	Gicleur maxi 122	Hauptdüse 122	Surtidor máximo 122
46	16.42309.000	1		Getto massimo 125	Main jet 125	Gicleur maxi 125	Hauptdüse 125	Surtidor máximo 125
47	16.42310.000	1		Getto massimo 128	Main jet 128	Gicleur maxi 128	Hauptdüse 128	Surtidor máximo 128
48	16.42311.000	1		Getto massimo 130	Main jet 130	Gicleur maxi 130	Hauptdüse 130	Surtidor máximo 130
49	31.63668.000	1		Vite registro minimo	Idle adjuster	Vis tarage ralenti	Einstellschraube Leerlauf	Tornillo registro minimo
50	22.39232.000	1		Molla minimo	Spring	Ressort ralenti	Feder Leerlauf	Muelle minimo
51	27.33550.000	1		Ritegno spillo	Collar, Th. Spring	Seeger aiguille	Nadelhalter	Recato aguja
52	31.63667.000	1		Viti coperchio	Screw, top	Vis couvercle	Schraube f. Deckel	Tornillos tapa
53	27.65911.000	1		Rondella	Washer	U.Scheibe	U.Scheibe	Arandela
54	25.87162.000	1		Polverizzatore	Needle jet	Pulvé riseur	Einspritzdüse	Pulverizador
55	27.33551.000	1		Ritegno polverizzatore	Needle jet holder	Seeger pulvé riseur	Einspritzdüsehalter	Recato pulverizador
56	31.02189.000	1		Vaschetta raccolta carburante	Fuel recovery tank	Cuve récupération carburant	Benzin-Auffangwanne	Cuba recogedor de combustible

Tav.14

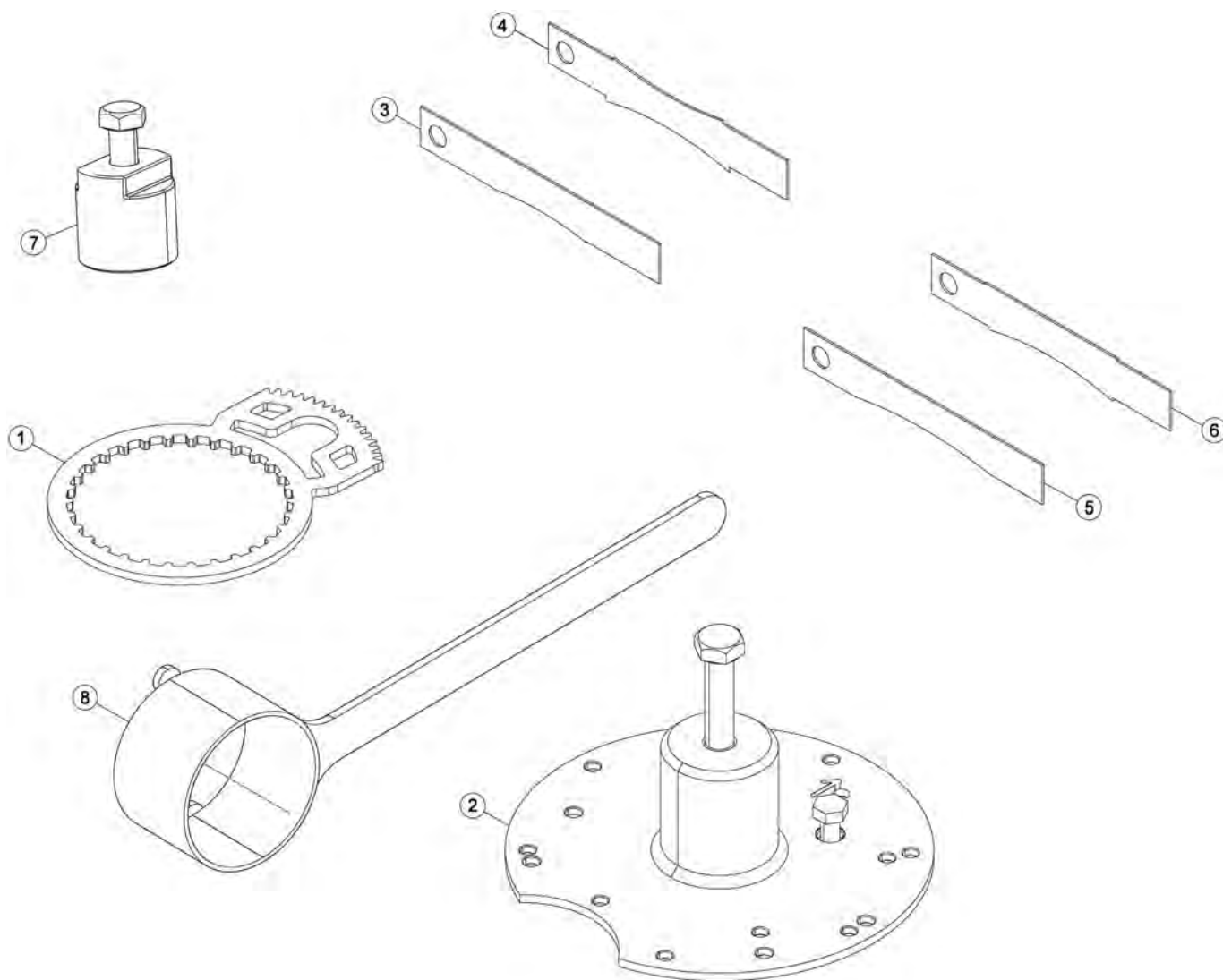

Pos Loc Pos Ps Pos	Numero Number Numéro Número Nummer	Q.tà Q.ty Q.té M.ge C.ad	Nota Note Note Nota Anm.	Descrizione	Description	Dé signation	Beschreibung	Descrìpziò n
1	007.14.000.00.00	1		Attrezzo bloccaggio trasmissione primaria	Holding Tool, Primary drive	Clé de fixation de la transmission principale	Halteschlüssel für Hauptantrieb	Llave para bloquear la transmisión primaria
2	007.14.010.80.00	1		Disaccoppiatore carter	Crankcase splitter	Sé parateur de carter	Entkoppler gehäuse	Desacoplador del cárter
3	007.44.010.00.00	1	125cc	Strumento misura squish	Squish measuring tool	Outil de mesure du squish	Werkzeug für Quetschkante	Herramienta para medir el squish
4	007.44.011.00.00	1	200cc- 200cc GB	Strumento misura squish	Squish measuring tool	Outil de mesure du squish	Werkzeug für Quetschkante ausmessen	Herramienta para medir el squish
5	007.44.012.00.00	1	250cc	Strumento misura squish	Squish measuring tool	Outil de mesure du squish	Werkzeug für Quetschkante ausmessen3	Herramienta para medir el squish
6	007.44.014.00.00	1	300cc	Strumento misura squish	Squish measuring tool	Outil de mesure du squish	Werkzeug für Quetschkante ausmessen	Herramienta para medir el squish
7	01.00040.000	1	250-300cc	Estrattore volano	Flywheel extractor	Extracteur pour volant	Auszieher für Schwungrad	Extractor volante
8	026.14.004.00.00	1	250-300cc	Attrezzo bloccaggio volano	Holding tool, flywheel	Clé de fixation volant	Halteschlüssel für Schwungrad	Llave para sostener el volante

Tav.31

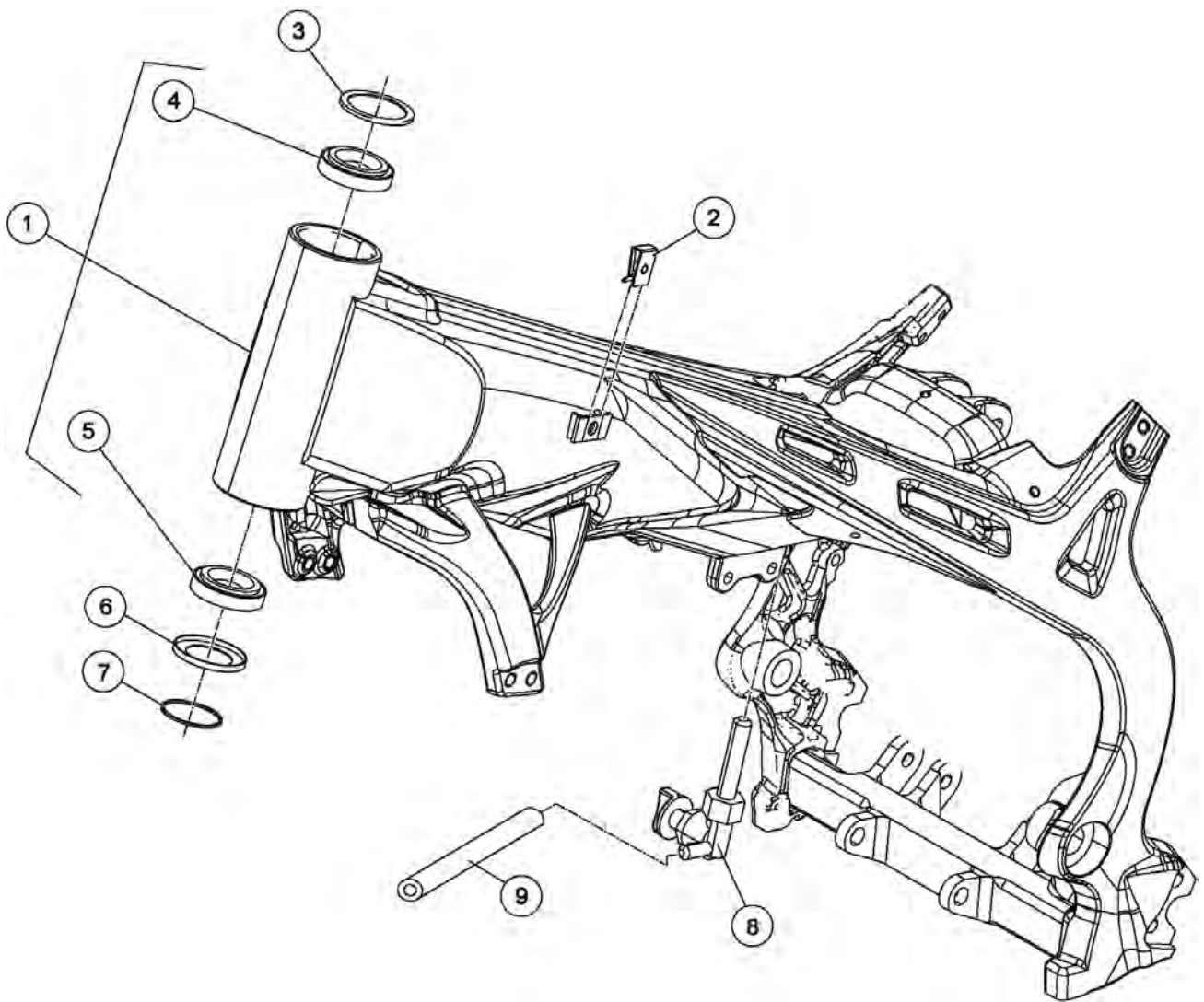

Pos Loc Pos Ps Pos	Numero Number Numé ro Número Nummer	Q.tà Q.ty Q.té M.ge C.ad	Nota Note Note Nota Anm.	Descrizione	Description	Dé signation	Beschreibung	Descrìciò n
1	007.31.400.80.51	1		Telaio	Frame	Cadre	Rahmen	Chasis
2	25.58065.000	2		Clip M5	Clip M5	Clip M5	Clip M5	Clip M5
3	28.17750.100	1		Scodellino parapolvere	Dust cover	Cuvette pare-poussié re	Staubdeckel	Cubeta gurdapolvo
4	12.98300.000	1		Cuscinetto conico 20x42x15	Conical bearing 20x42x15	Roulement conique 20x42x15	Lager 20x42x15	Cojinete conico 20x42x15
5	12.98300.000	1		Cuscinetto conico 20x42x15	Conical bearing 20x42x15	Roulement conique 20x42x15	Lager 20x42x15	Cojinete conico 20x42x15
6	10.67390.000	1		Anello parapolvere	Dust cover	Disque pare-poussié re	Staubdeckel	Disco gurdapolvo
7	10.66860.000	1		Anello OR 34,6x2,62	Ring OR 34,6x2,62	Circlips OR 34,6x2,62	Ring OR 34,6x2,62	Anillo OR 34,6x2,62
8	007.32.008.00.00	1		Rubinetto miscela	Fuel tap	Robinet melange		Grifo mezcla
9	007.32.009.00.00	1		Tubo benzina	Gasoline tube	Tube essence	benzinschlauch	Tubo gasolina

Tav.32

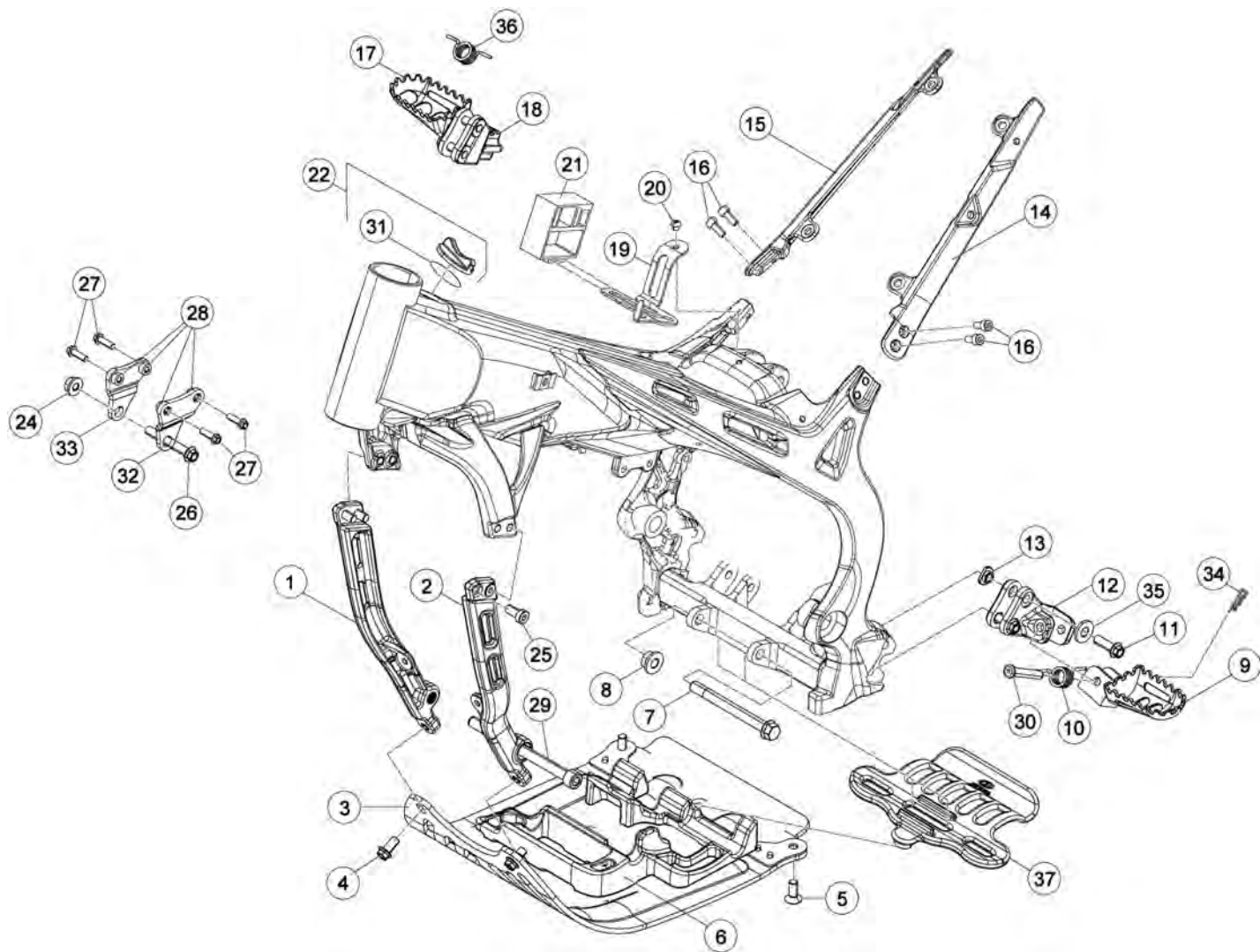

Tav.32

Pos Loc Ps Pos	Numero Number Numéro Nummer	Q.tà Q.ty Q.té M.ge C.ad	Nota Note Nota Anm.	Descrizione	Description	Dé signation	Beschreibung	Descrìpziò n
1	007.32.004.80.72	1		Staffa supporto motore Dx.	R.H. Engine support bracket	Bride support moteur D.	Motorsattelbefestigung R.	Brida soporte motor der.
2	007.32.003.80.72	1		Staffa supporto motore Sx.	L.H. Engine support bracket	Bride support moteur G.	Motorsattelbefestigung L.	Brida soporte motor izq.
3	007.32.140.80.00	1		Protezione motore	Engine protection	Protection moteur	Motorschutz	Protecció n motor
4	11.54521.000	2		Bullone M8x16	Bolt M8x16	Boulon M8x16	Bolzen M8x16	Tornillo M8x16
5	31.63930.000	2		Vite TSPCE 8.20	Screw TSPCE 8.20	Vis TSPCE 8.20	Schraube TSPCE 8.20	Tornillo TSPCE 8.20
6	007.32.044.00.00	1		Gomma protezione motore	Rubber pad, engine protection	Caoutchouc protection moteur	Gummistück Motorschutz	Goma protecció n motor
7	31.65627.000	1		Vite speciale M10x100 passo 1,25	Special screw M10x100 passo 1,25	Vis spéciale M10x100 passo 1,25	Spezialschraube M10x100 passo 1,25	Tornillo especial M10x100 passo 1,25
8	13.21050.000	1		Dado flangiato M10X1,25	Flanged nut M10X1,25	Ecrou bordé M10X1,25	Flanschmutter M10X1,25	Tuerca embreada M10X1,25
9	007.32.091.00.00	1		Pedana Poggiapiedi sx.	L.H. foot peg	Repose-pied gauche	Fußraste links	Estribera Izq.
10	22.62020.000	1		Molla pedana sx	L.H. footrest spring	Ressort repose-pied gauche	Rasten/Feder li.	Muelle izqui. Estribera
11	31.64070.000	4		Vite flangiata 8x30	Flanged screw 8x30	Vis à brides 8x30	Flanschschraube 8x30	Tornillo rebordeado 8x30
12	28.99304.059	1		Supporto pedana Sx.	L.H. footrest bracket	Support repose pied gauche	Halter für die linke fußraste	Soporte estribera izquierda
13	18.84645.000	4		Inserto speciale M8	Special insert M8	Insert spéciale M8	Gewindeinsatz M8	Inserto especial M8
14	007.32.130.40.50	1		Staffa supporto scatola filtro sx.	Airbox support bracket, L.H. RED	Bride support filtre air G. ROUGE	Luftfilterbefestigung L. ROT	Brida soporte filtro izq. ROJO
15	007.32.131.40.50	1		Staffa supporto scatola filtro dx.	Airbox support bracket, R.H. RED	Bride support filtre air R. ROUGE	Luftfilterbefestigung R. ROT	Brida soporte filtro der. ROJO
16	31.31050.000	4		Vite TCCE M6x16	Screw TCCE M6x16	Vis TCCE M6x16	Schraube TCCE M6x16	Tornillo TCCE M6x16
17	007.32.090.00.00	1		Pedana poggiapiedi dx.	R.H. foot peg	Repose-pied droit	Fußraste rechts	Estribera Der.
18	28.99294.059	1		Supporto pedana Dx.	R.H. footrest bracket	Support repose pied droit	Halter für die rechte fußraste	Soporte estribera derecha
19	007.32.110.00.05	1		Piastrina supporto centralina	Control unit support plate	Plaque support centrale	Halteplatte Steuerung	Placa soporte centralita
20	31.29810.000	1		Vite 5x12	Screw 5x12	Vis 5x12	Schraube 5x12	Tornillo 5x12
21	007.40.037.00.00	1		Gommino supporto centralina	Control unit cushion	Caoutchouc support centrale	Gummihalter Steuerung	Goma soporte centralita
22	007.32.060.80.59	1		Tappo serbatoio	Filler cap	Bouchon de ré servioir	Tankverschluss	Tapó n depó sito
24	13.17120.000	1		Dado M8 flangiato	Nut M8	Ecrou M8	Mutter M8	Tuerca M8
25	31.63881.000	4		Vite a brugola TCCE 8.16 bassa	Allen screw TCCE 8.16 bassa	Vis à 6 pans TCCE 8.16 bassa	Sechskantschraube TCCE 8.16	Tornillo a llave allen TCCE 8.16 bassa
26	11.55920.000	1		Bullone 8.60 rs ch10	Bolt 8.60 rs ch10	Boulon 8.60 rs ch10	Bolzen 8.60 rs ch10	Tornillo 8.60 rs ch10
27	11.49070.000	2		Bullone 6.50 rs ch 8	Bolt 6.50 rs ch 8	Boulon 6.50 rs ch 8	Bolzen 6.50 rs ch 8	Tornillo 6.50 rs ch 8
28	13.12610.000	2		Dado flangiato M6	Flanged nut M6	Ecrou bordé M6	Flanschmutter M6	Tuerca embreada M6
29	007.32.002.00.00	1		Vite TCCE M 10x127	Screw TCCE M 10x127	Vis TCCE M 10x127	Schraube TCCE M 10x127	Tornillo TCCE M 10x127
30	25.54467.000	2		Perno pedana	Footrest pin	Pivot repose-pied	Rasten Pin	Eje estribera
31	10.66680.000	1		Anello OR 28,25,33,49,2,62 viton	Ring OR 28,25,33,49,2,62 viton	Circlips OR 28,25,33,49,2,62 viton	Ring OR 28,25,33,49,2,62 viton	Anillo OR 28,25,33,49,2,62 viton
32	007.32.309.80.00	1	125cc	Staffa attacco cilindro sx.	Cylinder connection bracket L.H.	Bride attelage cylindre G.	Zylinderbefestigung L.	Brida anclaje cilindro izq.
32	007.32.305.80.00	1	200-250 300cc	Staffa attacco cilindro sx.	Cylinder connection bracket L.H.	Bride attelage cylindre G.	Zylinderbefestigung L.	Brida anclaje cilindro izq.
33	007.32.310.80.00	1	125cc	Staffa attacco cilindro dx.	Cylinder connection bracket R.H.	Bride attelage cylindre D.	Zylinderbefestigung R.	Brida anclaje cilindro der.
33	007.32.307.80.00	1	200-250 300cc	Staffa attacco cilindro dx.	Cylinder connection bracket R.H.	Bride attelage cylindre D.	Zylinderbefestigung R.	Brida anclaje cilindro der.
34	12.81993.000	2		Copiglia 3x20	Split pin 3x20	Goupille 3x20	Splint 3x20	Grupilla 3x20
35	27.49500.000	4		Rondella 8x18	Washer 8x18	Rondelle 8x18	U.Scheibe 8x18	Arandela 8x18
36	22.62010.000	1		Molla pedana dx	R.H. footrest spring	Ressort repose-pied droit	Rasten/Feder re.	Muelle derch. Estribera
37	007.32.045.00.00	1		Protezione link	Link protection	Protection bielles amortisseur	Stoßdämpferaufnahme	Protecció n vá stagos de amortig.

Tav.33

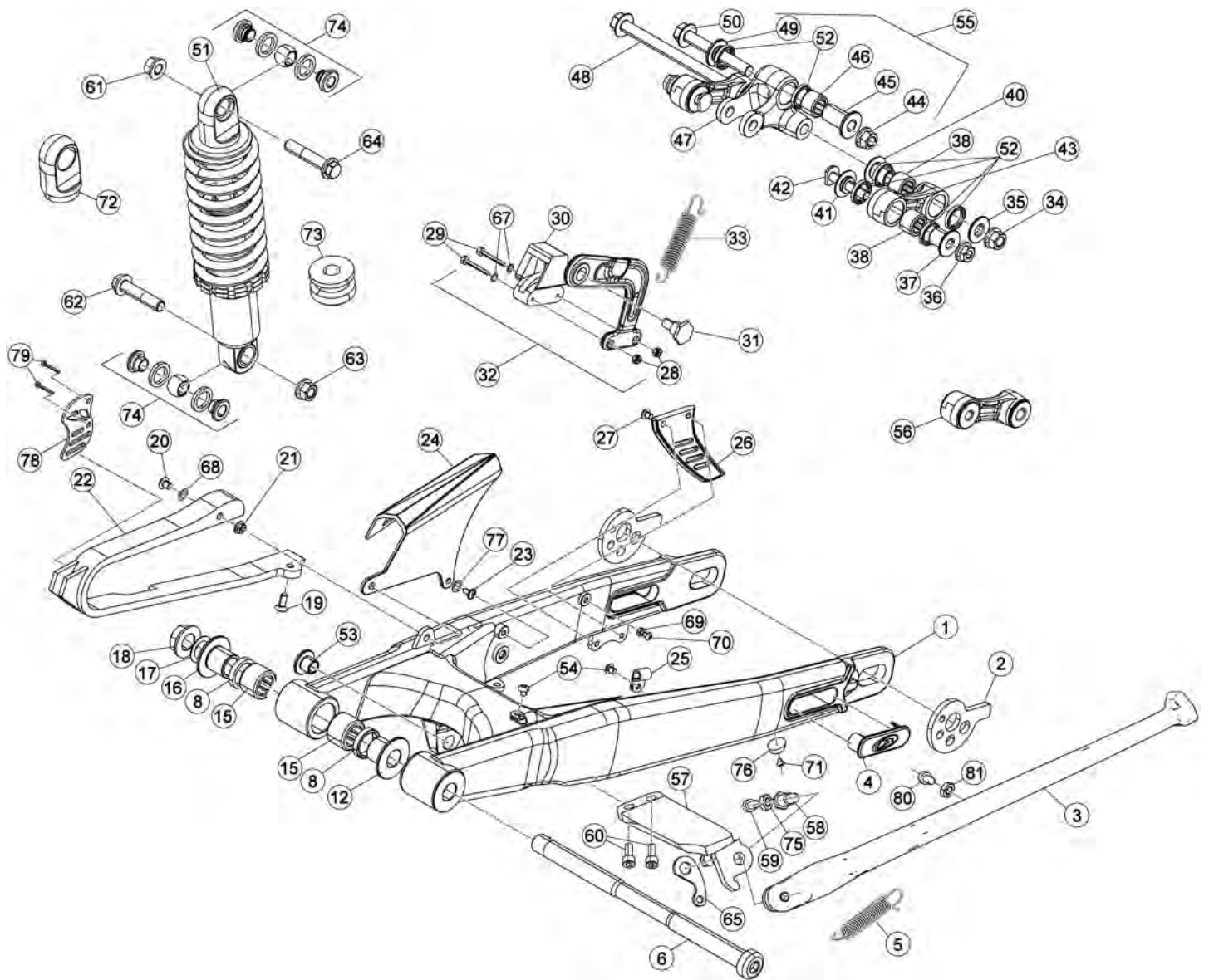

Tav.33

Pos Loc Pos Ps Pos	Numero Number Numéro Nummer	Q.tà Q.ty Q.té M.ge C.ad	Nota Note Note Nota Anm.	Descrizione	Description	Dé signation	Beschreibung	Descrìcì o n
1	007.33.200.80.72	1		Forcellone	Big fork	Fourche	Radschwinge	Horquilla
2	007.33.070.00.03	2		Registri catena (coppia)	Chain tighteners	Tend. de chaîne	Kettenspanner	Tens. de cadena
3	007.33.160.00.00	1		Cavalletto	Central stand	Bé quille	Kippständer	Caballette
4	007.33.011.10.59	2		Tappo forcellone	Big fork plug	Bouchon fourche	Radschwinge verschluß	Tapón horquilla
5	22.47024.000	1		Molla cavalletto	Central stand spring	Ressort bé quille	Feder Kippständer	Muelle caballette
6	007.33.020.00.00	1		Perno forcellone	Swingarm pivot	Axe fourche AR.	Schwingbolzen	Eje basculante
8	007.33.010.00.00	4		Parapolvere interno 22x28x4	Inner dust cover 22x28x4	Pare-pouss. Interne 22x28x4	Innerer Staubdeckel 22x28x4	Guardapolvo interior 22x28x4
12	007.33.112.00.00	1		Boccola interna	Inside bush	Douille int.	Büchse innen	Casquillo interior
15	11.22980.000	4		Boccola a rullini 22x28x16	Roller cage 22x28x16	Cage Aiguille 22x28x16	Rollenkäfig 22x28x16	Jaula rodillos 22x28x16
16	007.33.112.00.00	1		Boccola interna	Inside bush	Douille int.	Büchse innen	Casquillo interior
17	27.67510.000	1		Rondella 16.25.1	Washer 16.25.1	Rondelle 16.25.1	U.Scheibe 16.25.1	Arandela 16.25.1
18	13.29510.000	1		Dado speciale 16.1.25	Special nut 16.1.25	Ecrou spéciale 16.1.25	Spezialmutter 16.1.25	Tuerca especial 16.1.25
19	31.30500.000	1		Vite M6x12 TSPCE	Screw M6x12 TSPCE	Vis M6x12 TSPCE	Schraube M6x12 TSPCE	Tornillo M6x12 TSPCE
20	31.45110.000	1		Vite TBEI 6.35	Screw TBEI 6.35	Vis TBEI 6.35	Schraube TBEI 6.35	Tornillo TBEI 6.35
21	13.13020.000	1		Dado autobloccante M6	Self locking nut M6	Ecrou de sécurité M6	Mutter, selbstsichernd M6	Tuerca de seguridad M6
22	007.33.118.00.00	1		Tassello guidacatena	Sliding block	Cheville guide de chaîne	Schwingschleifklotz	Protector cadena/basculante
23	31.96829.000	1		Vite TCBEI M5x8 10.9	Screw TCBEI M5x8 10.9	Vis TCBEI M5x8 10.9	Schraube TCBEI M5x8 10.9	Tornillo TCBEI M5x8 10.9
24	007.33.050.10.59	1		Copricatena	Chain guard	Carter de chaîne	Kettenabdeckung	Cubre-cadena
25	15.14300.000	2		Fascetta fissaggio tubo freno	Brake pipe fastening clamp	Collier fixation tube frein arriere	Befestigungsschelle Bremsschlauch	Brida fijacion freno post.
26	007.33.051.10.59	1		Protezione corona	Ring gear protection	Protection couronne dentee	Zahnkranzschutz	Protección corona
27	31.29810.000	2		Vite 5x12	Screw 5x12	Vis 5x12	Schraube 5x12	Tornillo 5x12
28	13.10910.000	2		Dado autobloccante M4	Self locking nut M4	Ecrou de sécurité M4	Mutter, selbstsichernd M4	Tuerca de seguridad M4
29	31.26210.000	2		Vite TBCE m4x20	Screw TBCE m4x20	Vis TBCE m4x20	Schraube TBCE m4x20	Tornillo TBCE m4x20
30	007.33.054.00.00	1		Gomma pattino guida catena	Chain guide shoe rubber	Caoutchouc doigt guide-chaîne	Gummistück Gleitauflage	Goma patín guía cadena
31	007.33.056.00.00	1		Bullone speciale	Special bolt	Boulon spéciale	Spezialschraube	Tornillo especial
32	007.33.053.00.00	1		Pattino catena	Chain shoe	Doigt chaîne	Gleitauflage	Patín cadena
33	22.81112.000	1		Molla ritorno	Return spring	Ressort de retour	Rückschlagfeder	Muelle de retorno
34	13.21050.000	1		Dado flangiato M10X1,25	Flanged nut M10X1,25	Ecrou bordé M10X1,25	Flanschmutter M10X1,25	Tuerca embreadada M10X1,25
35	007.33.032.00.00	1		Distanziale d.10 1.4,75	Spacer d.10 1.4,75	Entretoise d.10 1.4,75	Distanzstück d.10 1.4,75	Distanciadador d.10 1.4,75
36	13.17040.000	1		Dado autoblocc. flangiato M8x1,25	Self locking nut, flanged M8x1,25	Ecrou de sécurité bordé M8x1,25	Mutter, selbstsichernd M8x1,25	Tuerca de seguridad embred. M8x1,25
37	007.33.035.00.00	1		Distanziale d.8 1.18,75	Spacer d.8 1.18,75	Entretoise d.8 1.18,75	Distanzstück d.8 1.18,75	Distanciadador d.8 1.18,75
38	007.33.038.00.00	2		Astuccio a rulli 15x21x14 RS	Roller cage 15x21x14 RS	Cage à roul. 15x21x14 RS	Rollenlagerkäfig 15x21x14 RS	Jaula rodillos 15x21x14 RS
40	007.33.034.00.00	1		Distanziale d.10 1.18,75	Spacer d.10 1.18,75	Entretoise d.10 1.18,75	Distanzstück d.10 1.18,75	Distanciadador d.10 1.18,75
41	007.33.033.00.00	1		Distanziale d.8 1.4,75	Spacer d.8 1.4,75	Entretoise d.8 1.4,75	Distanzstück d.8 1.4,75	Distanciadador d.8 1.4,75
42	007.33.037.00.00	1		Vite speciale	Special screw	Vis spéciale	Spezialschraube	Tornillo especial
43	007.33.031.00.00	1		Bielletta	Biellette	Connecting rod	Bolzensange	Bieleta
44	13.21050.000	1		Dado flangiato M10X1,25	Flanged nut M10X1,25	Ecrou bordé M10X1,25	Flanschmutter M10X1,25	Tuerca embreadada M10X1,25
45	007.33.036.00.00	1		Distanziale lungo	Long spacer	Entretoise long	Lang Distanzstück	Distanciadador largo
46	007.33.039.00.00	2		Astuccio a rulli 15x21x12	Roller cage 15x21x12	Cage à roul. 15x21x12	Rollenlagerkäfig 15x21x12	Jaula rodillos 15x21x12
47	007.33.030.00.00	1		Bilanciere	Lever	Balancier	Kipphebel	Balancin
48	11.62080.000	1		Bullone 10.125 1,25 (10.9)	Bolt 10.125 1,25 (10.9)	Boulon 10.125 1,25 (10.9)	Bolzen 10.125 1,25 (10.9)	Tornillo 10.125 1,25 (10.9)
49	007.33.046.00.00	1		Distanziale corto	Short spacer	Entretoise courte	Kurzer Abstandhalter	Distanciadador corto
50	11.62070.000	1		Bullone 10.75 1,25 (10.9)	Bolt 10.75 1,25 (10.9)	Boulon 10.75 1,25 (10.9)	Bolzen 10.75 1,25 (10.9)	Tornillo 10.75 1,25 (10.9)
51	007.33.024.80.00	1		Ammortizzatore	Damper	Amortisseur	Stoßdämpfer	Amortiguador
52	007.33.045.00.00	10		Anello parapolvere GD 15x21x3	Dust cover GD 15x21x3	Disque pare-poussière GD 15x21x3	Staubdeckel GD 15x21x3	Disco guardapolvo GD 15x21x3
53	007.33.009.00.00	2		Boccola	Bush	Moyeu	Büchse	Buje
54	31.30080.000	2		Vite 5x10 TTLIC	Screw 5x10 TTLIC	Vis 5x10 TTLIC	Schraube 5x10 TTLIC	Tornillo 5x10 TTLIC
55	007.33.030.80.00	1		Bilanciere completo	Lever, assy.	Balancier complet	Kipphebel kpl.	Balancin compl.
56	007.33.031.80.00	2		Bielletta	Biellette	Connecting rod	Bolzensange	Bieleta
57	007.33.361.00.05	1		Supporto cavalletto	Central stand support	Support bé quille	Halter für Ständer	Soporte caballette
58	007.33.071.00.00	1		Vite speciale cavalletto	Stand special screw	Vis spéciale bé quille	Spezialschraube für Ständer	Tornillo especial caballette
59	31.31050.000	1		Vite M6x16	Screw M6x16	Vis M6x16	Schraube M6x16	Tornillo M6x16
60	31.63880.000	2		Vite a brugola 8.16	Allen screw 8.16	Vis à 6 pans 8.16	Sechskantschraube 8.16	Tornillo a llave allen 8.16
61	13.21050.000	1		Dado flangiato M10X1,25	Flanged nut M10X1,25	Ecrou bordé M10X1,25	Flanschmutter M10X1,25	Tuerca embreadada M10X1,25
62	11.62060.000	1		Bullone fiss. Ammort. 10.50 1,25	Damper sec. bolt 10.50 1,25	Boulon fix. amortisseur 10.50 1,25	Befestigungsbolzen 10.50 1,25	Tornillo fij amortiguador 10.50 1,25
63	13.21050.000	1		Dado flangiato M10X1,25	Flanged nut M10X1,25	Ecrou bordé M10X1,25	Flanschmutter M10X1,25	Tuerca embreadada M10X1,25
64	11.62050.000	1		Bullone fiss. ammortizzatore 10x45	Damper sec. bolt 10x45	Boulon fix. amortisseur 10x45	Befestigungsbolzen 10x45	Tornillo fij amortiguador 10x45
65	25.57636.000	1		Piastrina aggancio molla	Bracket spring	Plaque accoch. ressort	Plättchen federanlenkung	Placa eng. muelle
67	27.34650.000	2		Rondella	Washer	Rondelle	U.Scheibe	Arandela
68	27.40500.000	1		Rondella 6x13	Washer 6x13	Rondelle 6x13	U.Scheibe 6x13	Arandela 6x13
69	13.11000.000	1		Dado M5	Nut M5	Ecrou M5	Mutter M5	Tuerca M5
70	31.29820.000	1		Vite M5x16 TBCE	Screw M5x16 TBCE	Vis M5x16 TBCE	Schraube M5x16 TBCE	Tornillo M5x16 TBCE
71	C24.50.005.00.00	1		Vite M4,8x13 NERA	Screw M4,8x13 BLACK	Vis M4,8x13 NOIR	Schraube M4,8x13 SCHWARZ	Tornillo M4,8x13 NEGRO
72	007.33.042.00.00	1		Mozzo	Hub	Moyeu	Nabe	Buje

Tav.33

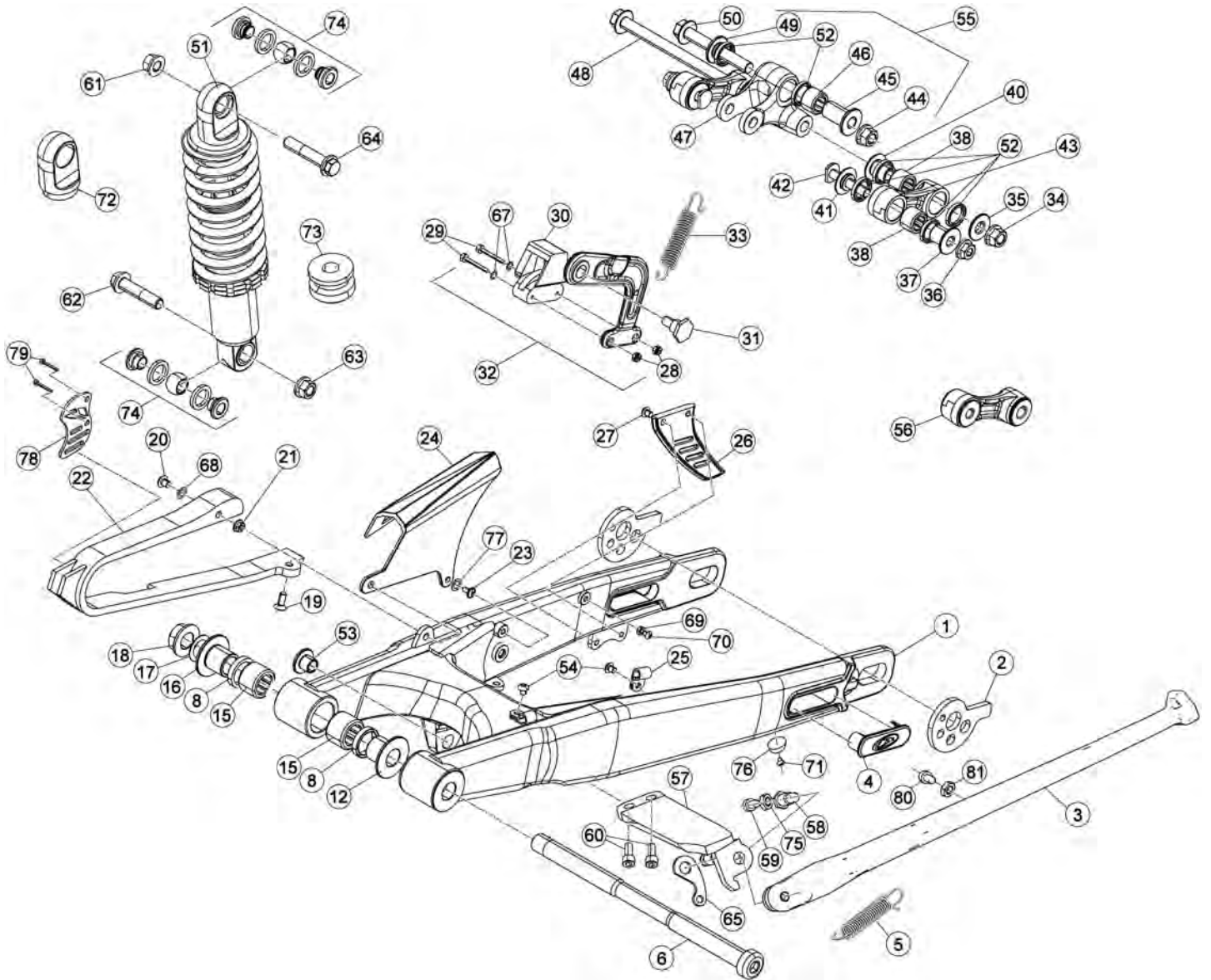

Tav.33

Pos Loc Pos Ps Pos	Numero Number Numéro Número Nummer	Q.tà Q.ty Q.té M.ge C.ad	Nota Note Nota Anm.	Descrizione	Description	Dé signation	Beschreibung	Descrìciò n
73	007.33.041.00.00	1		Tampone	Buffer	Silentbloc	Puffer	Silent-block
74	007.33.043.00.00	2		Snodo	Ball joint	Joint a rotule	Kugelgelenk	Articulaciò n esferica
75	13.11500.000	1		Dado M6x3,5 CH10	Nut M6x3,5 CH10	Ecrou M6x3,5 CH10	Mutter M6x3,5 CH10	Tuerca M6x3,5 CH10
76	007.33.073.00.00	1		Gommino battuta cavalletto	Stand stop rubber	Caoutchouc buté e bé quille	Anschlaggummi Ständer	Goma tope caballete
77	27.36500.000	1		Rondella Ø5	Washer Ø5	Rondelle Ø5	U.Scheibe Ø5	Arandela Ø5
78	007.33.080.00.03	1		Coperchio pignone	Sprocket cover	Couvercle pignon	Deckel Ritzel	Tapa piñón
79	31.23566.000	2		Vite M4x5,9	Screw M4x5,9	Vis M4x5,9	Schraube M4x5,9	Tornillo M4x5,9
80	31.96831.000	1		Vite M5x30	Screw M5x30	Vis M5x30	Schraube M5x30	Tornillo M5x30
81	13.11000.000	1		Dado M5x5 CH8	Nut M5x5 CH8	Ecrou M5x5 CH8	Mutter M5x5 CH8	Tuerca M5x5 CH8

Tav.33A

Pos Loc Ps Pos	Numero Number Numéro Número Nummer	Q.tà Q.ty Q.té M.ge C.ad	Nota Note Nota Anm.	Descrizione	Description	Dé signation	Beschreibung	Descrìpiò n
1	007.33.024.80.00	1		Ammortizzatore	Shock absorber	Amortisseur	Stoßdämpfer	Amortiguador
2	007.33.043.00.00	2		Snodo	Ball joint	Joint a rotule	Kugelgelenk	Articulació n esférica
3	007.33.042.00.00	1		Mozzo	Hub	Moyeu	Nabe	Buje
4	007.33.345.00.00	1		Tappo	Plug	Bouchon	Verschluss	Tapó n
5	007.33.346.00.00	1		Molla	Spring	Ressort	Feder	Muelle
6	007.33.347.00.00	1		Seeger	Seeger	Seeger	Seegerring	Seeger
7	007.33.348.00.00	1		Guidastelo	Guide rod	Guide tige	Pumpenstü ckfü hrung	Guja espiga
8	007.33.025.00.00	1		Stelo	Rod	Tige	Pumpenstück	Espiga
9	007.33.350.00.00	1		Pistone	Piston	Piston	Kolben	Pistó n
10	007.33.026.00.00	1		Diaframma	Diaphragm	Diaphragme	Biegeplatte	Diafragma
11	007.33.352.00.00	1		Cilindro	Cylinder	Cylindre	Zylinder	Cilindro
12	007.33.353.00.00	1		Testa	Head	Tête	Kopf	Cabeza
13	007.33.354.00.00	1		Valvola	Valve	Soupape	Füllventil	Válvula
14	007.33.047.00.00	1		Kit ghiera-distanziale	Ring nuts-spacer	Douilles-entretoise	Gewinderingen-Distanzstück	Casquillos-dostanciador
15	007.33.059.00.00	1		Molla	Spring	Ressort	Feder	Muelle
16	007.33.041.00.00	1		Tampone	Buffer	Silentbloc	Puffer	Silent-block
17	007.33.027.00.00	1		Kit guarnizioni	Gasket set	Jeu garnitures	Dichtungssatz	Grupo juntas
18	007.33.357.00.00	1		Kit testa-cilindro	Head-cylinder set	Jeu tête-cylindre	Dämpferkopf-Zylinder Gruppe	Grupocabeza-cilindro
19	007.33.028.00.00	1		Stelo completo	Operating rod, assy.	Tige compl.	Kolbenstange, kompl.	Varilla completa

Tav.34

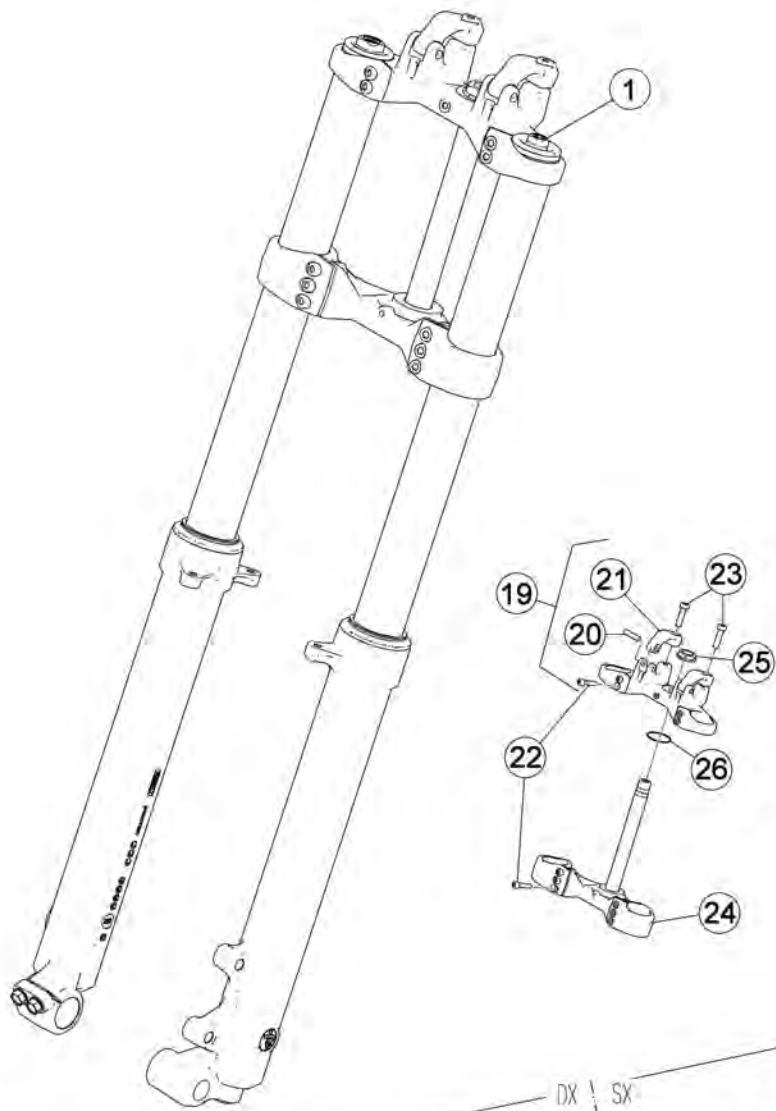

- Olio forcella tipo: SAE6.1
- Oil fork type: SAE6.1
- Gabel Öl-Typ: SAE6.1
- Huile de fourche type: SAE6.1
- Tipo de aceite horquilla: SAE6.1

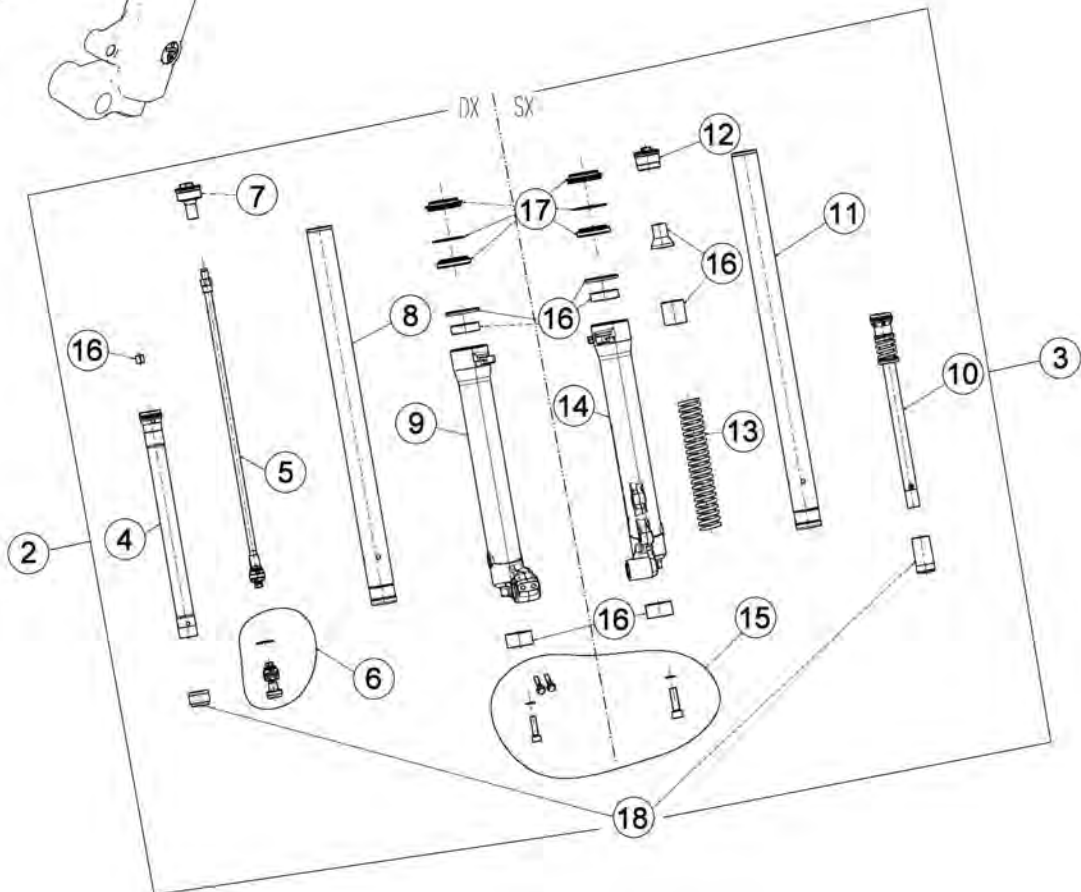

Tav.34

Pos Loc Pos Ps Pos	Numero Number Numé ro Número Nummer	Q.tà Q.ty Q.té M.ge C.ad	Nota Note Note Nota Anm.	Descrizione	Description	Dé signation	Beschreibung	Descrìpziò n
1	007.34.804.80.51	1	125-200cc	Forcella completa	Stirrup assy.	Fourchette compl.	Schaltgabel, Kompl.	Horquilla compl.
1	007.34.801.80.51	1	250-300cc	Forcella completa	Stirrup assy.	Fourchette compl.	Schaltgabel, Kompl.	Horquilla compl.
2	007.34.805.80.51	1	125-200cc	Gamba dx completa	RH leg assembly	Tube D. compl.	Rechte Beineinheit	Pata derecha completa
2	007.34.802.80.51	1	250-300cc	Gamba dx completa	RH leg assembly	Tube D. compl.	Rechte Beineinheit	Pata derecha completa
3	007.34.806.80.51	1	125-200cc	Gamba sx completa	LH leg assembly	Tube G. compl.	Linke Beineinheit	Pata izquierda completa
3	007.34.803.80.51	1	250-300cc	Gamba sx completa	LH leg assembly	Tube G. compl.	Linke Beineinheit	Pata izquierda completa
4	007.34.926.00.00	1		Cartuccia idraulica forcella dx	R.H. Hydraulic fork spares	Cartouche hydraulique dr.	Hydraulischer Gabeldaempfer Rechts	Cartucho hidraulico horquilla der.
5	007.34.927.00.00	1	250-300cc	Gruppo pacco distensione	Extension pack assembly	Ensemble paquet extension	Baugruppe zugstufe	Conjunto paquete extensió n
5	007.34.928.00.00	1	125-200cc	Gruppo pacco distensione	Extension pack assembly	Ensemble paquet extension	Baugruppe zugstufe	Conjunto paquete extensió n
6	007.34.929.00.00	1	250-300cc	Gruppo pacco compressione	Compression pack assembly	Ensemble paquet compression	Baugruppe compressionpacket	Conjunto paquete compresió n
6	007.34.930.00.00	1	125-200cc	Gruppo pacco compressione	Compression pack assembly	Ensemble paquet compression	Baugruppe compressionpacket	Conjunto paquete compresió n
7	007.34.931.00.00	1		Tappo destro	R.H. cap	Bouchon droite	Verschluß R.	Tapó n derecho
8	007.34.948.00.00	1	125-200cc	Stelo Dx. compl.	R.H. slider assy	Montant D. compl.	Bein, Kpl. R.	Deslizable der. compl.
8	007.34.945.00.00	1	250-300cc	Stelo Dx. compl.	R.H. slider assy	Montant D. compl.	Bein, Kpl. R.	Deslizable der. compl.
9	007.34.950.00.51	1		Fodero dx	Sleeve R.H.	Protection Droit	Schutzstück Recht	Protecció n Der
10	007.34.936.00.00	1	125-200cc	Cartuccia idraulica forcella sx	L.H. Hydraulic fork spares	Cartouche hydraulique ga.	Hydraulischer Gabeldaempfer Links	Cartucho hidraulico horquilla izq.
10	007.34.935.00.00	1	250-300cc	Cartuccia idraulica forcella sx	L.H. Hydraulic fork spares	Cartouche hydraulique ga.	Hydraulischer Gabeldaempfer Links	Cartucho hidraulico horquilla izq.
11	007.34.949.00.00	1	125-200cc	Stelo Sx. compl.	L.H. slider assy	Montant G. compl.	Bein, Kpl. L.	Deslizable izrda. compl.
11	007.34.946.00.00	1	250-300cc	Stelo Sx. compl.	L.H. slider assy	Montant G. compl.	Bein, Kpl. L.	Deslizable izrda. compl.
12	007.34.919.00.00	1		Tappo sinistro	L.H. cap	Bouchon gauge	Verschluß L.	Tapó n izquierdo
13	22.52703.000	1		Molla	Spring	Ressort	Feder	Muelle
14	007.34.951.00.51	1		Fodero sx	Sleeve L.H.	Protection Gauche	Schutzstück Linke	Protecció n Izq.
15	007.34.922.00.00	1		Kit viti	Kit screws	Jeu vis	Schraubensatz	Kit tornillos
16	007.34.923.00.00	1		Kit boccole	Bush kit	Kit douille	Buchsekit	Kit manguito
17	007.34.924.00.00	1		Kit guarnizioni	Packings kit	Jeu joints	Dichtungensatz	Grupo juntas
18	007.34.940.00.00	1		Gr. tamponamento idraulico	Hydraulic seals kit	Joints d' é tanché ité	Hydraulischen Puffern	Kit de tampó nes hidrá ulicos
19	007.34.320.80.00	1		Testa di sterzo	Steering head	Tête de direction	Gabelkopf	Tija superior
20	007.34.322.00.00	2		Perno cavallotto	U-bolt pin	Axe etrier	Zapfen Brü cke	Perno brida
21	007.34.331.42.04	2		Cavallotto	U bolt	Etrier	Brü cke	Brida
22	31.34510.000	7		Vite t.c.c.e. M6x20	Screw t.c.c.e. M6x20	Vis t.c.c.e. M6x20	Schraube t.c.c.e. M6x20	Tornillo t.c.c.e. M6x20
23	31.63911.000	2		Vite TCCE M8.30	Screw TCCE M8.30	Vis TCCE M8.30	Schraube TCCE M8.30	Tornillo TCCE M8.30
24	007.34.310.80.00	1		Base di sterzo con perno	Steering crown with pin	Socle de direction avec pivot	Gabelbrü cke mit Bolzen	Base de direcció n con perno
25	007.34.005.00.00	1		Dado canotto	Head tube nut	Ecrou colonne	Lenkrohrmutter	Tuerca
26	10.66301.000	1		Anello OR 17,96x2,62	O-Ring 17,96x2,62	Bague d' é tanché ité 17,96x2,62	O-Ring 17,96x2,62	Anillo OR 17,96x2,62

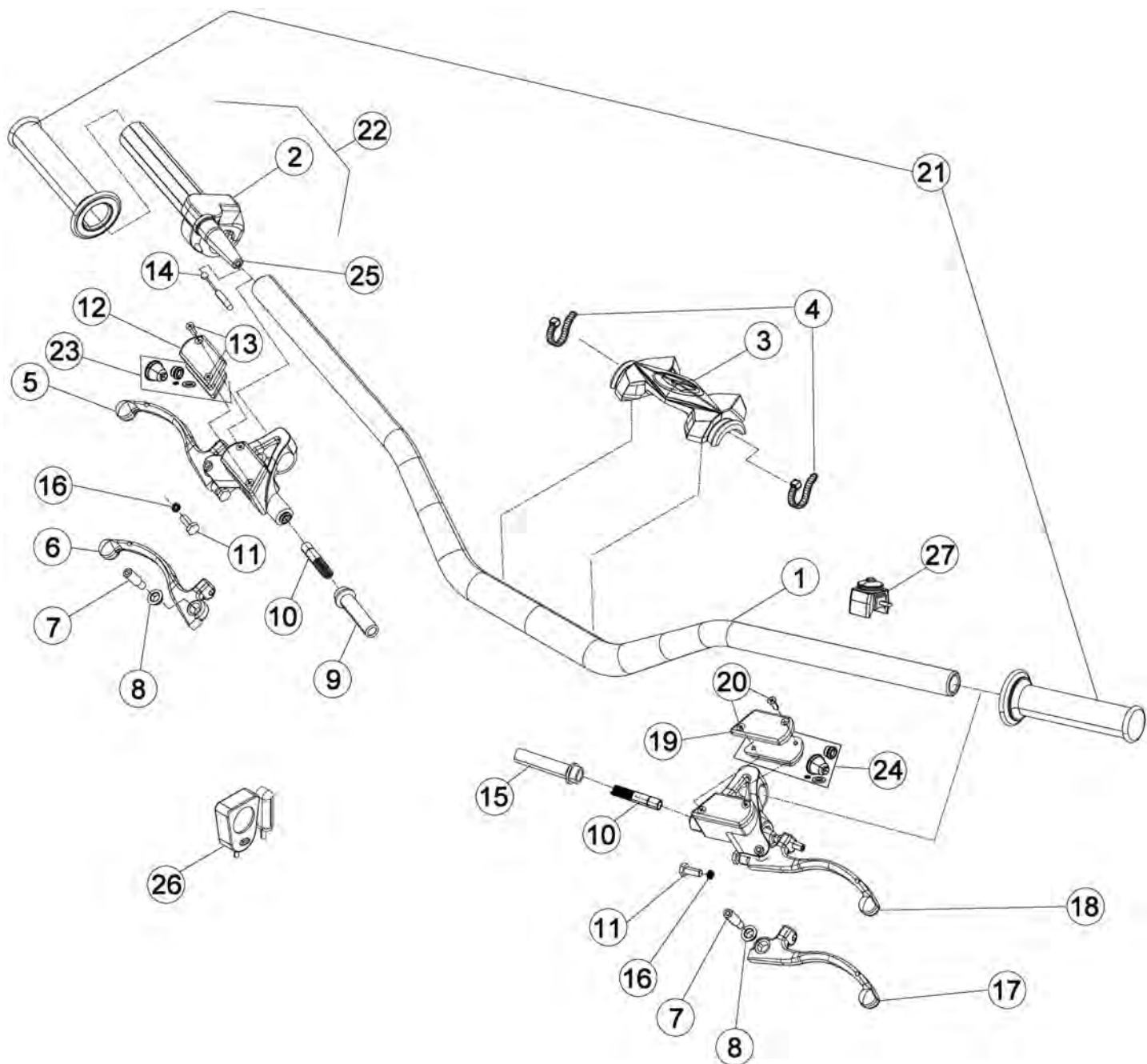

Tav.35

Pos Loc Ps Pos	Numero Number Numéro Número Nummer	Q.tà Q.ty Q.té M.ge C.ad	Nota Note Nota Anm.	Descrizione	Description	Dé signation	Beschreibung	Descrìpziò n
1	22.20464.059	1		Manubrio	Handlebars	Guidon	Lenker	Manillar
2	12.55960.000	1		Coperchio comando gas	Throttle control cover	Couvercle comm. gaz	Abdeckung Gasdrehgriff	Cubierta mando gas
3	007.35.066.00.00	1		Protezione manubrio	Handlebar protection	Protection guidon	Lenkerschutz	Proteccion manillar
4	15.13020.000	2		Fascetta di nylon	Cable tie	Collier	Kabel-Schelle	Abrazadera
5	007.36.000.80.52	1		Leva comando freno	Brake lever	Levier du frein	Bremshebel	Palanca freno
6	007.36.011.00.00	1		Leva freno ant.	Fr. br. lever	Lev. fr. AV.	Vorderradbremshebel	Pal. fr. del.
7	31.96818.000	2		Vite speciale	Special screw	Vis spéciale	Spezialschraube	Tornillo especial
8	11.26465.000	2		Boccola	Bush	Moyeu	Büchse	Buje
9	29.09123.000	1		Tubo freno ant.	Front brake tube	Tuyau du frein AV.	Vordere Bremsleitung	Tubo freno delantero
10	20.05083.800	2		Kit pistoncino pompa ant.	Piston kit front master cyl.	Kit piston. mai tre cyl. AV.	Kolbensatz vorderhauptbremszylinder	Kit pistón bomba del.
11	31.88601.000	2		Vite registro freno anteriore	Adjusting screw	Vis réglage	Einstellschrauben	Tornillo reg.
12	12.68107.052	1		Coperchio pompa olio	Oil pump cover	Couvercle pompe huile	Ölpumpendeckel	Tapa bomba aceite
13	31.23410.052	2		Vite fiss. tappo serbatoio freno anteriore	Front brake tank cap fastening screw	Vis de fixation bouchon réservoir frein avant	Befestigungsschraube Vorderbremse Öltankstöpsel	Tornillo fijación tapón depósito freno delantero
14	007.35.014.00.00	1		Trasmissione acceleratore	Throttle transmission	Transmissioin accélérateur	Gaszug	Transmisión acelerador
15	007.35.026.00.00	1		Tubo comando frizione	Clutch control pipe	Tube commande embrayage	Kupplungssteuerungsleitung	Tubo mando embrague
16	22.38701.000	2		Molla regolazione frizione	Clutch spring	Ressort réglage embrayage	Stellfeder	Muelle regulac. embrague
17	007.35.011.00.00	1		Leva com.friz.nuda	Clutch lever only	Levier complet embrayage nue	Kupplungshebel	Palanca embrague
18	007.35.001.80.52	1		Leva comando frizione	Clutch control lever	Levier de commande embrayage	Kupplungshebel	Palanca mando embrague
19	12.68106.052	1		Coperchio serbatoio	Reservoir Lid	Couvercle De Réservoir	Behälterdeckel	Calderín Lid
20	31.23410.052	2		Vite fiss. tappo serbatoio freno anteriore	Front brake tank cap fastening screw	Vis de fixation bouchon réservoir frein avant	Befestigungsschraube Vorderbremse Öltankstöpsel	Tornillo fijación tapón depósito freno delantero
21	22.18531.000	1		Coppia manopole	Grips (couple)	Poignées (couple)	Handgriffpaar	Manecilla (juego)
22	12.55029.000	1	125-250-300cc	Comando gas	Throttle control	Comm. gaz	Gasdrehgriff	Mando gas
22	12.55091.000	1	200cc	Comando gas	Throttle control	Comm. gaz	Gasdrehgriff	Mando gas
23	20.05075.000	1		Tappo completo	Complete cap	Bouchon complet	Verschluß komplett	Tapón completo
24	20.05074.000	1		Tappo completo	Complete cap	Bouchon complet	Verschluß komplett	Tapón completo
25	16.34080.000	1		Gommino	Rubber buffer	Caoutchouc	Gummi	Goma
26	007.35.060.00.00	1		Contakm digitale	Speedometer	Compteur	Tachometer	Cuenta km. tr.
27	007.35.057.00.00	1		Interruttore arresto motore	Switch for engine cut-out	Interrupteur arrêt moteur	Schalter für Motorabstellung	Interruptor parada motor



- Olio freni tipo: DOT4
 - Brake fluid type: DOT4
 - Bremsflüssigkeit Typ: DOT4
 - Liquide de frein type: DOT4
 - El líquido de frenos tipo: DOT4

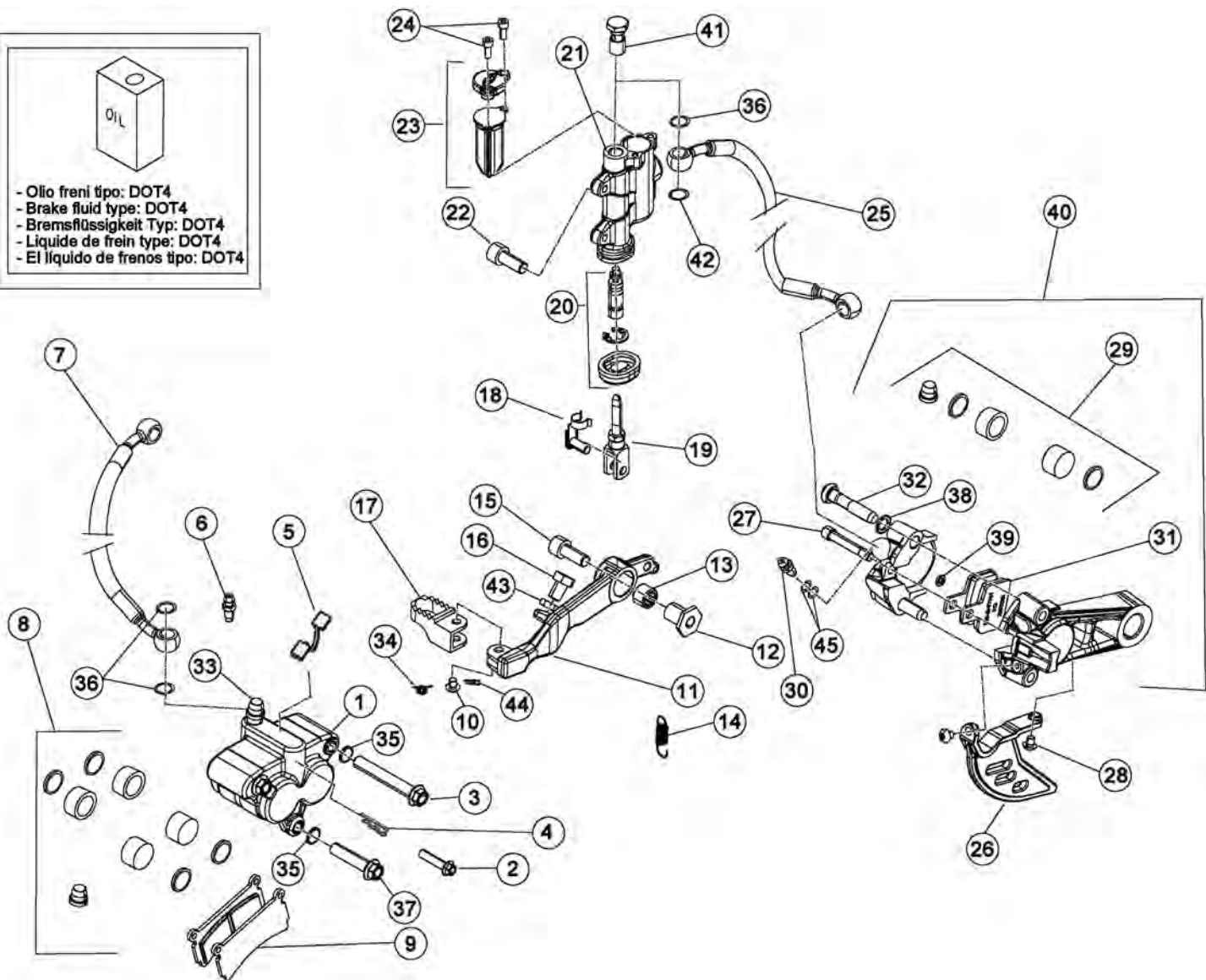

Tav.36

Pos Loc Ps Pos	Numero Number Numéro Nummer	Q.tà Q.ty Q.té M.ge C.ad	Nota Note Nota Anm.	Descrizione	Description	Dé signation	Beschreibung	Descrìpziò n
1	25.03059.000	1		Pinza freno post.	Rear disk brake caliper	Etrier de frein AR.	Bremsszange	Pinza del freno tras.
2	11.70521.000	1		Bullone fiss. Pastiglie	Brake pads fastening bolt	Boulon de fixation jeu past. fr.	Befestigungsbolzen Bremsszange	Tornillo fijaciòn Juego past. Frenos
3	11.55900.000	1		Bullone 8x55	Bolt 8x55	Boulon 8x55	Bolzen 8x55	Tornillo 8x55
4	22.32206.000	1		Molla ferma pastiglie pinza	Brake pads spring for pliers	Ressort arret plaquettes	Haltefeder	Muelle pastillas pinza
5	25.98915.000	1		Protezione pastiglie freno	Brake pads cover	Protection jeu past. fr.	Bremsschutz	Protecciòn Juego past. Frenos
6	31.96801.000	1		Vite spurgo pinza	Special screw	Vis pour pince	Spezial schraube	Tornillo aliento pinza
7	29.09123.000	1		Tubo freno ant.	Front brake tube	Tuyau du frein AV.	Vordere Bremsleitung	Tubo freno delantero
8	20.02714.000	1		Kit pistoncini e guarniz. Pinza	Piston e oil seal for pliers	Jeu petit pistons et joint pince	Reparatursatz Bremsszange	Juego piston y guarnicion pinza
9	25.25352.000	1		Pastiglie per pinza	Brake pads	Plaquettes pince	Bremssbeläge hinten	Pastillas pinza
10	25.54450.000	1		Perno pedale freno post.	Pivot for rear brake pedal	Pivot pour pé dale frein AR.	Pedalzapfen	Perno pedal freno tras.
11	007.36.140.00.00	1		Pedale freno	Brake pedal	Pé dale frein	Fussbremspedal	Pedal freno
12	11.26611.000	1		Boccola	Bush	Moyeu	Büchse	Buje
13	11.22220.000	1		Boccola a rullini 12x18x16 2rs	Roller cage 12x18x16 2rs	Cage Aiguille 12x18x16 2rs	Rollenkäfig 12x18x16 2rs	Jaula rodillos 12x18x16 2rs
14	007.36.044.00.00	1		Molla pedale freno	Brake pedal spring	Ressort Pé dale Frein	Feder Fussbremspedal	Muelle pedal de freno
15	31.63890.000	1		Vite 8x20 TCCE	Screw 8x20 TCCE	Vis 8x20 TCCE	Schraube 8x20 TCCE	Tornillo 8x20 TCCE
16	11.46250.000	1		Bullone 5x12	Bolt 5x12	Boulon 5x12	Bolzen 5x12	Tornillo 5x12
17	22.90052.000	1		Mozzetto con pedana	Footrest hub	Moyeu a/repouse pieds	Rasten Nabe Fußbremshebel	Puntera pedal freno
18	28.93130.000	1		Staffa	Bracket	Support	Halterung	Soporte
19	10.84040.000	1		Asta com.pompa freno post	Rear brake rod	Tige de commande pompe frein	Betaetigungsstange Bremse hi.	Varilla bomba freno post.
20	007.36.151.00.00	1		Kit pistoncino	Piston kit	Jeu piston	Kolbensatz	Juego piston
21	007.36.150.80.00	1		Pompa freno post.	Rear brake master cyl.	Mâitre cylindre fr. AR.	Hauptbremszylinder Hinterradbremse	Bomba fr. tras.
22	31.31050.000	2		Vite t.c.c.e.M6x15	Screw t.c.c.e.M6x15	Vis t.c.c.e.M6x15	Schraube t.c.c.e.M6x15	Tornillo t.c.c.e.M6x15
23	007.36.152.00.00	1		Kit tappo	Plug kit	Jeu bouchon	Verschluss gruppe	Kit tapòn
24	007.36.153.00.00	2		Vite M4x12 DIN 912	Screw M4x12 DIN 912	Vis M4x12 DIN 912	Schraube M4x12 DIN 912	Tornillo M4x12 DIN 912
25	007.36.073.00.00	1		Tubo freno posteriore	Rear brake tube	Tuyau du frein AR.	Hintere Bremsleitung	Tubo freno trasero
26	007.36.175.10.59	1		Copridisco	Disc cover	Couvre-disque	Scheibenabdeckung	Cubredisco
27	11.70520.000	1		Bullone fiss. Pastiglie	Brake pads fastening bolt	Boulon de fixation jeu past. fr.	Befestigungsbolzen Bremsszange	Tornillo fijaciòn Juego past. Frenos
28	31.26200.000	2		Vite 4x14 TCIC	Screw 4x14 TCIC	Vis 4x14 TCIC	Schraube 4x14 TCIC	Tornillo 4x14 TCIC
29	007.36.079.00.00	1		Kit pistoncini e guarniz. Pinza	Piston e oil seal for pliers	Jeu petit pistons et joint pince	Reparatursatz Bremsszange	Juego piston y guarnicion pinza
30	007.36.078.00.00	1		Bullone forato + spurgo	Pierced bolt + Bleed	Boulon avec trou + Vidange	Bolzen + Ablass	Tornillo + Purga
31	007.36.071.80.00	1		Pastiglie freno post.	Rear brake pads	Pastill. de freins AR.	Hinterbremsbelag	Pastillas frenos tras.
32	007.36.077.00.00	2		Bullone fiss. pinza	Plier fastening bolt	Boulon de fixation pince	Befestigungsbolzen Bremsszange	Tornillo fijaciòn pinza
33	11.65040.000	1		Bullone forato 10x1 x tubo freno	Special bolt	Boulon 10x1 x tube frein	Hohlschraube F.Bremse	Tornillo esp. talad.10.1
34	22.62090.000	1		Molla ritorno pedale freno	Return brake pedal spring	Ressort de retour frein	Bremspedal Feder	Muelle retorno palanca freno
35	27.49500.000	2		Rondella 8x18	Washer 8x18	Rondelle 8x18	U.Scheibe 8x18	Arandela 8x18
36	16.50510.000	3		Guarnizione 10x15x1 in rame	Gasket 10x15x1 copper	Joint 10x15x1 cuivre	Dichtung 10x15x1 Kupfer	Junta 10.15.1 (cobre)
37	11.55470.000	1		Bullone M8x35	Bolt M8x35	Boulon M8x35	Bolzen M8x35	Tornillo M8x35
38	27.56055.000	1		Rondella	Washer	Rondelle	U.Scheibe	Arandela
39	007.36.076.00.00	1		Rondella	Washer	Rondelle	U.Scheibe	Arandela
40	007.36.170.80.00	1		Pinza freno post.	Rear disk brake caliper	Etrier de frein AR.	Bremsszange	Pinza del freno tras.
41	11.65040.000	1		Bullone forato 10x1 x tubo freno	Special bolt	Boulon 10x1 x tube frein	Hohlschraube F.Bremse	Tornillo esp. talad.10.1
42	16.50511.000	1		Guarnizione 10x15x2 rame	Packing 10x15x2 rame	Joint 10x15x2 rame	Dichtung 10x15x2 rame	Junta 10x15x2 rame
43	13.10990.000	1		Dado 5,3,5 ch8	Nut 5,3,5 ch8	Ecrou 5,3,5 ch8	Mutter 5,3,5 ch8	Tuerca 5,3,5 ch8
44	12.81995.000	1		Copiglia 2x15	Split pin 2x15	Goupille 2x15	Splint 2x15	Grupilla 2x15
45	007.36.081.00.00	2		Rondella	Washer	Rondelle	U.Scheibe	Arandela

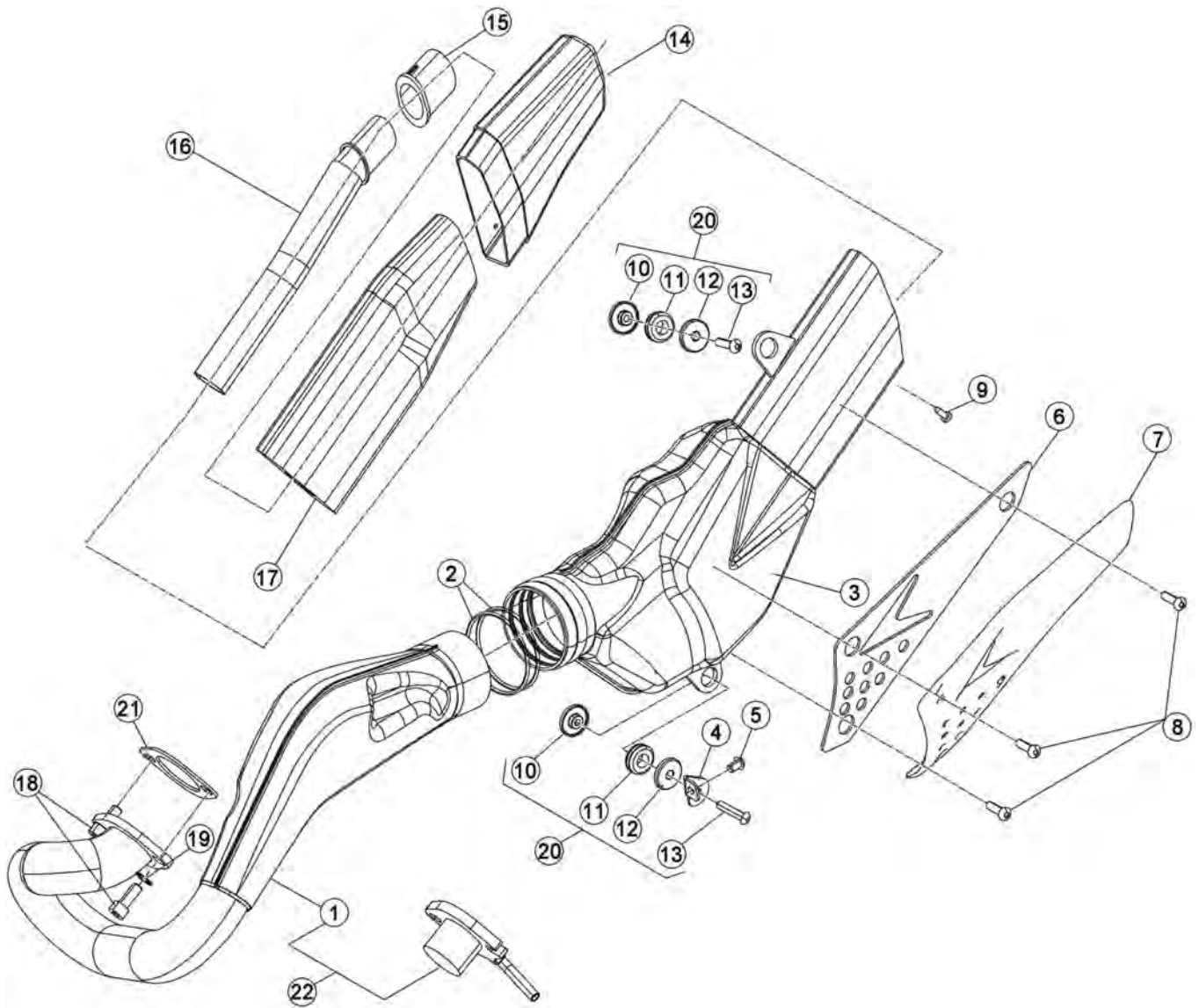

Tav.37

Pos Loc Ps Pos	Numero Number Numéro Número Nummer	Q.tà Q.ty Q.té M.ge C.ad	Nota Note Note Nota Anm.	Descrizione	Description	Dé signation	Beschreibung	Descrìpziò n
1	007.37.501.80.00	1	125cc	Collettore di scarico	Exhaust manifold	Collecteur d' échapp.	Abgaskrü mmer	Colector de escape
1	007.37.401.80.00	1	200cc	Collettore di scarico	Exhaust manifold	Collecteur d' échapp.	Abgaskrü mmer	Colector de escape
1	007.37.038.80.00	1	250-300cc	Collettore di scarico	Exhaust manifold	Collecteur d' échapp.	Abgaskrü mmer	Colector de escape
2	007.37.024.00.00	2		Anello OR	Ring	Bague d' é tanché ité	O-Ring	Anillo OR
3	007.37.431.80.00	1	125cc	Silenziatore	Silencer	Silencieux	Schalldä mpfer	Silenciador
3	007.37.430.80.00	1	200cc	Silenziatore	Silencer	Silencieux	Schalldä mpfer	Silenciador
3	007.37.028.80.00	1	250-300cc	Silenziatore	Silencer	Silencieux	Schalldä mpfer	Silenciador
4	007.37.007.15.00	1		Staffa supporto marmitta	Silencer bracket	Bride support silencieux	Befestigung Auspuff	Soporte escape
5	31.95510.000	1		Vite flangiata TBCE 6x12	Flanged screw TBCE 6x12	Vis à brides TBCE 6x12	Flanschschraube TBCE 6x12	Tornillo rebordeado TBCE 6x12
6	007.37.061.00.00	1		Feltro isolante protez. marmitta	Soundproofing felt silencer shield	Feutre isolant prot. silenc.	Daemmaterial seitenteil Auspuffverkleidung	Fieltro aislante protecció n escape
7	007.37.160.10.59	1		Paracalore marmitta	Silencer heat guard	Pare-chaueur silencieux	Wä rmeschutz Auspufftopf	Protecció n calor ilenciador
8	31.96829.000	3		Vite TCBEI M5x8 10.9	Screw TCBEI M5x8 10.9	Vis TCBEI M5x8 10.9	Schraube TCBEI M5x8 10.9	Tornillo TCBEI M5x8 10.9
9	31.23500.000	3		Vite 4.2x13	Screw 4.2x13	Vis 4.2x13	Schraube 4.2x13	Tornillo 4.2x13
10	007.37.036.00.00	2		Scodellino	Stop washer	Rondelle d' ar	Federaufnahme	Platillo
11	007.37.035.00.00	2		Silent block	Silentbloc	Silent block	Puffer	Silent block
12	007.37.037.00.00	2		Scodellino filettato	Threaded cup	Cuvette fileté	Gewindeteller	Cubeta filete
13	31.30790.000	2		Vite TBCE 6.25	Screw TBCE 6.25	Vis TBCE 6.25	Schraube TBCE 6.25	Tornillo TBCE 6.25
14	007.37.031.00.00	1		Terminale di scarico	Exhaust piper	Tuyau d' é chappement	Auspuff	Escape
15	007.37.056.00.00	1		Gommino	Rubber buffer	Caoutchouc	Gummi	Goma
16	007.37.052.00.00	1		Tube forato	Pierced tube	Tuyau avec trou	Hohlsllauch	Tube
17	007.37.055.00.00	1	125-200cc	Materiale fonoassorbente	Sound-absorbing material	Maté riau insonore	Schalldä mpfendem	Materiale fonoassorbente
17	007.37.084.00.00	1	250-300cc	Materiale fonoassorbente	Sound-absorbing material	Maté riau insonore	Schalldä mpfendem	Materiale fonoassorbente
18	31.63890.000	2		Vite 8x20 TCCE	Screw 8x20 TCCE	Vis 8x20 TCCE	Schraube 8x20 TCCE	Tornillo 8x20 TCCE
19	27.48000.000	2		Rondella grower 8	Grower washer 8	Rondelle Grower 8	Federring Grower 8	Arandela elá stica Grower 8
20	007.37.034.80.00	2		Silent block	Silentbloc	Silent block	Puffer	Silent block
21	16.80700.000	1		Guarnizione scarico	Exhaust manifold gasket	Joint coll. Ech.	Dichtung Abgaskrü mmer	Junta colector de escape
22	007.37.601.80.00	1	125cc	Collettore omologazione	Exhaust manifold, homologation	Collecteur d' homologation	Abgaskrü mmer Zulassungs	Colector de homologació n
22	007.37.039.80.00	1	250-300cc	Collettore omologazione	Exhaust manifold, homologation	Collecteur d' homologation	Abgaskrü mmer Zulassungs	Colector de homologació n

Tav.38

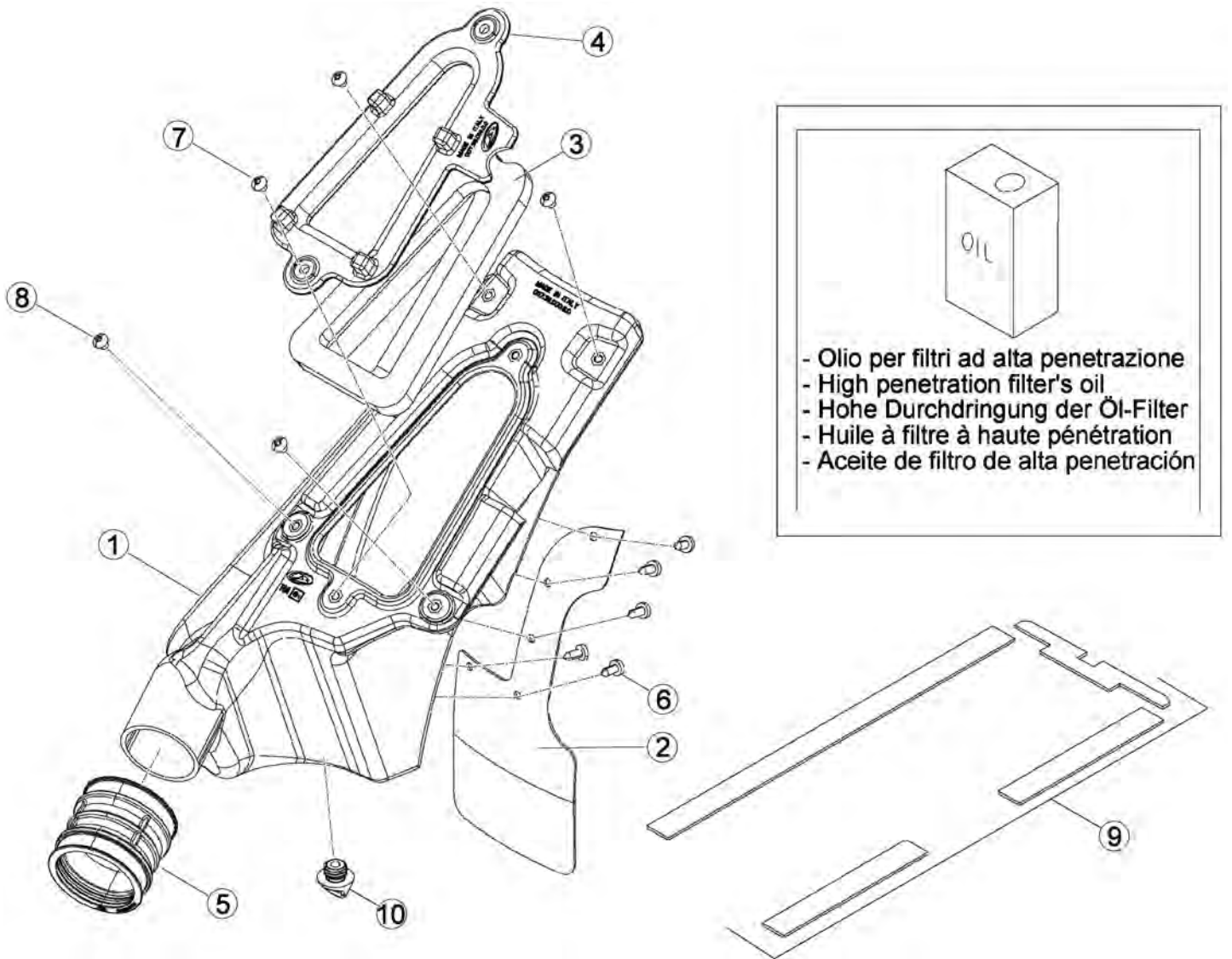

Pos Loc Pos Ps Pos	Numero Number Numé ro Número Nummer	Q.tà Q.ty Q.té M.ge C.ad	Nota Note Note Nota Anm.	Descrizione	Description	Dé signation	Beschreibung	Descrìpziò n
1	007.38.000.00.00	1		Scatola filtro	Filter box	Boî tier du filtre	Lufiltergehä use	Caja del filtro
2	007.38.001.00.00	1		Protezione ammortizzatore	Guard	Protection	Schutz	Protección
3	007.38.004.00.00	1		Elemento filtrante	Filtering element	Elément filtrant	Lufilterelement	Filtro
4	007.38.014.10.59	1		Coperchio scatola filtro	Filter case cover	Couvercle boî te filtre	Filtergehä usedeckel	Tapa caja filtro
5	22.13643.000	1		Manicotto scatola filtro	Filter box sleeve	Manchon boî te du filtre	Filtergehä usemuffe	Manguito caja filtro
6	31.23580.000	5		Vite 4,8x13	Screw 4,8x13	Vis 4,8x13	Schraube 4,8x13	Tornillo 4,8x13
7	31.29810.000	2		Vite 5x12	Screw 5x12	Vis 5x12	Schraube 5x12	Tornillo 5x12
8	31.29826.000	4		Vite 5x10 TBCEI	Screw 5x10 TBCEI	Vis 5x10 TBCEI	Schraube 5x10 TBCEI	Tornillo 5x10 TBCEI
9	007.38.020.80.00	1		Kit guarnizioni airbox	Airbox gasket kit	Joint boî te filtre	Kit Dichtung Filtergehä use	Juego junta caja depurador
10	29.10293.000	1		Tappo	Plug	Bouchon	Deckel	Tapa

Tav.39

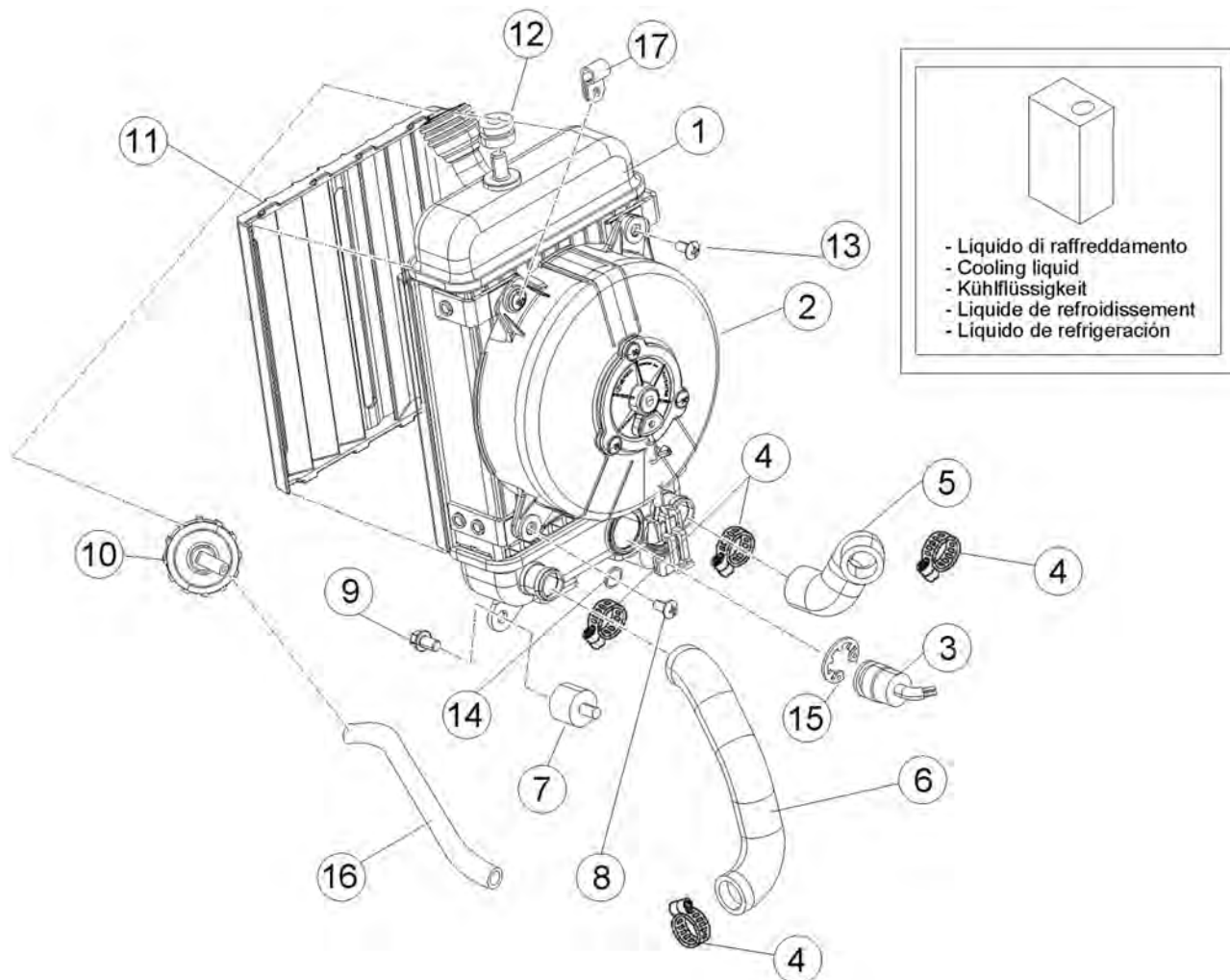

Pos	Numero	Q.tà	Nota	Descrizione	Description	Dé signation	Beschreibung	Descrìpiò n
Loc	Number	Q.ty	Note					
Pos	Numé ro	Q.té	Note					
Ps	Nú mero	M.ge	Nota					
Pos	Nummer	C.ad	Anm.					
1	007.39.200.00.00	1		Radiatore	Cooler	Radiateur	Kühler	Radiador
2	007.39.030.00.00	1		Elettroventola	Electric fan	Electro-ventilateur	Elektroluterrad	Electroventilador
3	007.39.220.00.00	1		Termointerruttore	Thermal switch	Thermo-régulateur	Umschalter	Interruptor térmico
4	15.15230.000	4		Fascetta 15x25	Clamp 15x25	Collier 15x25	Schelle 15x25	Abrazadera 15x25
5	007.39.003.00.00	1		Tubo raffreddamento	Cooling tube	Tuyau de refroid.	Kühlleitung	Conducto refriger.
6	29.15864.000	1		Tubo radiatore-pompa	Radiator-Pump hose	Tuyau radiateur-pompe	Leitung Kühler-Wasserpumpe	Tubo radiador-bomba
7	28.91942.000	2		Silent block	Silentbloc	Silent block	Puffer	Silent block
8	31.30570.000	1		Vite TTLIC 6.20 testa 12	Screw TTLIC 6.20 testa 12	Vis TTLIC 6.20 testa 12	Schraube TTLIC 6.20 testa 12	Tornillo TTLIC 6.20 testa 12
9	11.46501.000	2		Bullone M6x10	Bolt M6x10	Boulon M6x10	Bolzen M6x10	Tornillo M6x10
10	29.01821.000	1	125-200-250cc	Tappo radiatore REV3	Radiator plug REV3	Bouchon radiateur REV3	Kühlerdeckel REV3	Tapa de radiador REV3
10	007.39.014.00.00	1	300cc	Tappo radiatore	Radiator plug	Bouchon radiateur	Kühlerdeckel	Tapa de radiador
11	16.45543.159	1		Griglia radiatore	Radiator grille	Calandre	Kühlergrill	Reja del radiador
12	16.34905.000	1		Gommino kontakm	Odometer gasket	Joint caoutchouc compteurKM	Gummidichtung für Kilometerzähler	Junta de goma cuentaKM
13	31.30520.000	3		Vite 6x16 TTLIC	Screw 6x16 TTLIC	Vis 6x16 TTLIC	Schraube 6x16 TTLIC	Tornillo 6x16 TTLIC
14	27.43000.000	2		Rondella in gomma 6.20.3	Rubber washer 6.20.3	Rondelle en caoutchouc 6.20.3	Gummiunterlegscheibe 6.20.3	Arandela de goma 6.20.3
15	28.25380.000	1		Seeger 20i	Circlip 20i	Circlip 20i	Seeger 20i	Seeger 20i
16	29.15814.000	1		Tubo gomma (0,7m)	Rubber hose (0,7m)	Tuyau en caoutchouc (0,7m)	Gummischlauch (0,7m)	Tubo en goma (0,7m)
17	007.19.001.00.00	1		Fascetta a nastro c/gomma	Band clamp	Collier à bande	Spannband	Abrazadera de banda

Tav.40

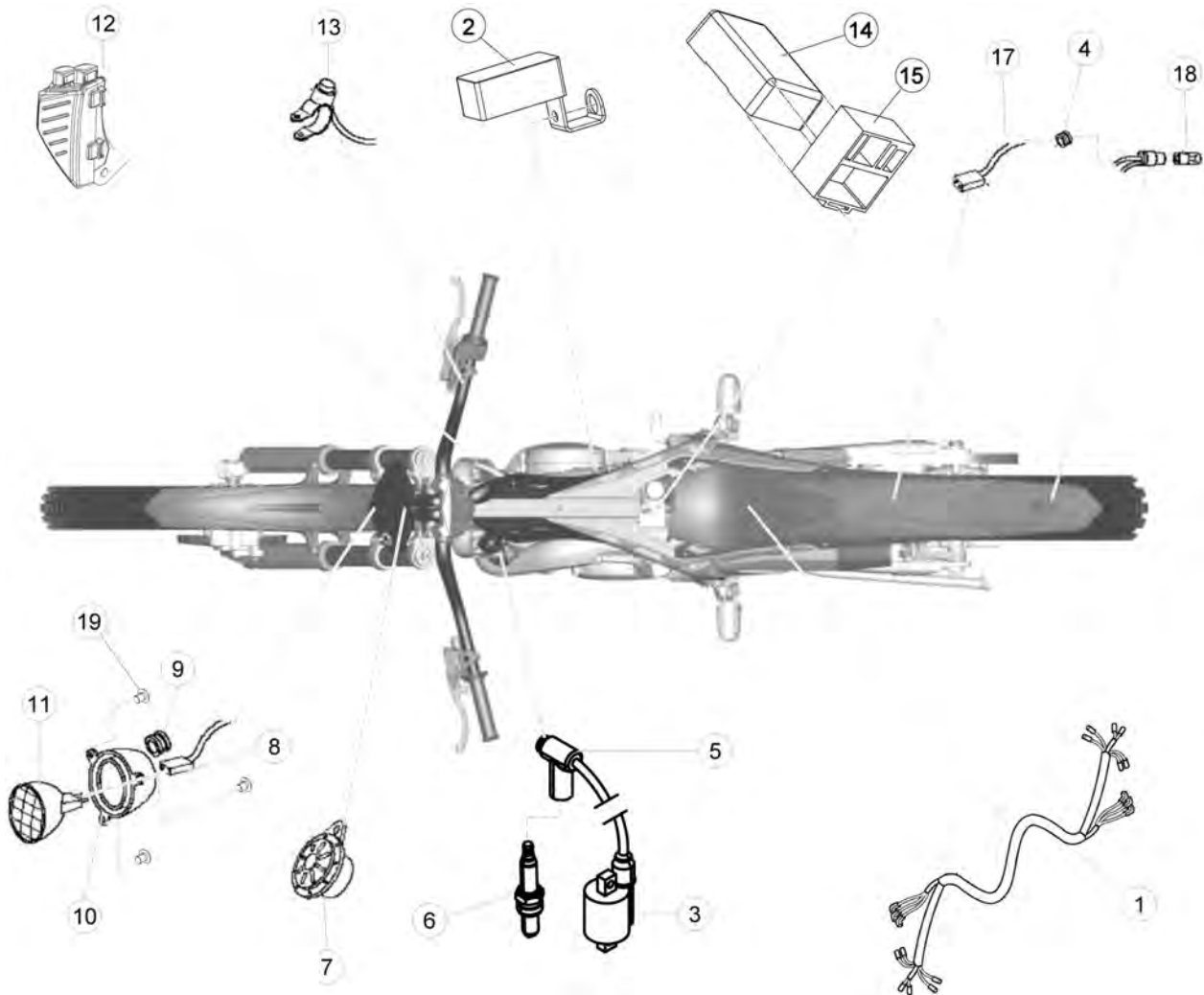

Pos Loc Pos Ps Pos	Numero Number Numéro Número Nummer	Q.tà Q.ty Q.té M.ge C.ad	Nota Note Note Nota Anm.	Descrizione	Description	Dé signation	Beschreibung	Descrisción
1	007.40.310.00.00	1		Impianto centrale	Electric equipment	Installation centrale	Zentraler Kabelbaum	Instalacion central
2	007.40.340.80.00	1		Regolatore	Regulator	Régulateur	Regler	Regulador
3	11.20682.800	1		Bobina	Coil	Bobine	Spule	Bobina
4	16.34903.000	2		Gommino fissaggio cavi	Rubber pad	Pièce caoutchouc	Gummistück	Goma
5	27.13514.000	1		Raccordo candela	Plug fitting	Raccord bougie	Kerzenanschluß	Racor bujía
6	12.25220.000	1	125-200cc	Candela	Spark plug	Bougie	Zündkerze	Bujía
6	036.11.000.00.00	1	250-300cc	Candela	Spark plug	Bougie	Zündkerze	Bujía
7	007.40.050.00.00	1		Avvisatore acustico	Warning horn	Avertisseur sonore	Hupe	Claxon
8	18.01516.000	1		Impianto elettrico anteriore	Front harness	Installation électrique AV.	Elektrische anlage vorne	Sistema eléctrico del.
9	16.34906.000	1		Gommino passacavo	Fairlead rubber ring	Joint en caoutchouc passe-câble	Kabeldurchgangsgummi	Junta de goma pasa-cable
10	12.03161.059	1		Corpo proiettore	Reflector housing	Corps du projecteur	Scheinwerfergehäuse	Cuerpo faro
11	21.16751.000	1		Lampadina proiettore	Headlamp bulb	Ampoule projecteur	Scheinwerferlampe	Lámpara faro
12	007.40.014.80.00	1		Dip luci	Switch	Commodo feux	Lichtschalter	Mando luces
13	007.35.057.00.00	1		Interruttore arresto motore	Switch for engine cut-out	Interrupteur arrêt moteur	Schalter für Motorabstellung	Interruptor parada motor
14	007.10.011.00.00	1	125cc	Centralina digitale	CDI unit	Bobine digital (C.D.I.)	Steuergerät	Centralita digital
14	007.10.048.83.00	1	200cc	Centralina digitale	CDI unit	Bobine digital (C.D.I.)	Steuergerät	Centralita digital
14	007.10.046.83.00	1	250cc	Centralina digitale	CDI unit	Bobine digital (C.D.I.)	Steuergerät	Centralita digital
14	007.10.045.00.00	1	300cc	Centralina digitale	CDI unit	Bobine digital (C.D.I.)	Steuergerät	Centralita digital
15	007.40.037.00.00	1		Gommino supporto centralina	Control unit cushion	Caoutchouc support centrale	Gummihalter Steuerung	Goma soporte centralita
17	007.40.124.00.00	1		Impianto posteriore	Rear harness	Circuit post.	Anlage hinten	Instalación tras.
18	21.15655.000	1		Lampadina fanalino posteriore	Tail lamp bulb	Ampoule feu AR.	Rücklichtlampe	Lámpara piloto
19	31.22550.000	3		Vite 2,9.10 TCIC	Screw 2,9.10 TCIC	Vis 2,9.10 TCIC	Schraube 2,9.10 TCIC	Tornillo 2,9.10 TCIC

Tav.41

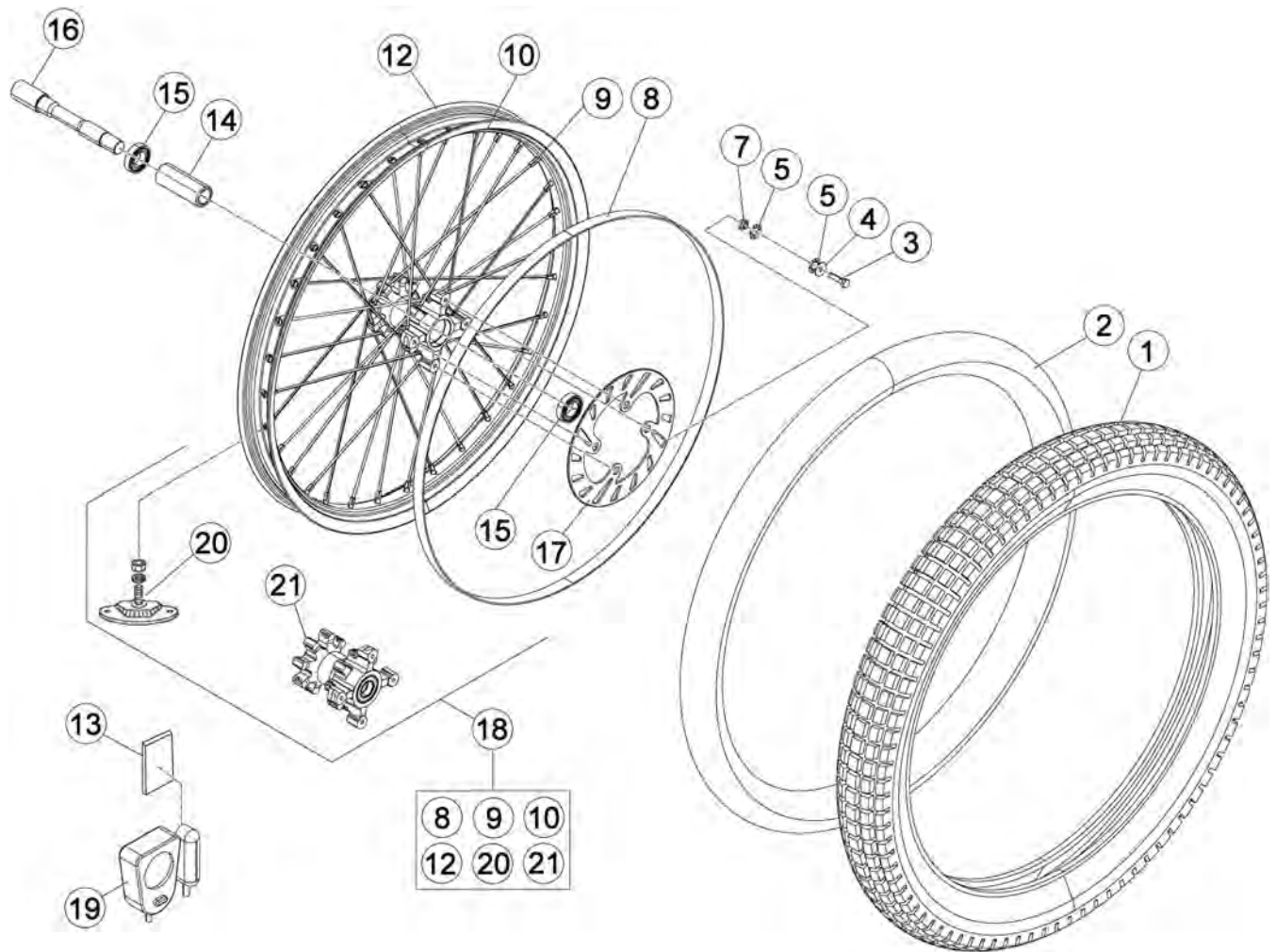

Pos Loc Pos Ps Pos	Numero Number Numé ro Nú mero Nummer	Q.tà Q.ty Q.té M.ge C.ad	Nota Note Nota Anm.	Descrizione	Description	Dé signation	Beschreibung	Descrìpiò n
1	12.79400.000	1		Copertura	Cover	Couvercle	Abdeckung	Cubierta
2	12.16410.000	1		Camera d' aria	Tubular braid	Chambre à air	Schlauch	Camara
3	11.49513.000	4		Vite 6.25	Screw 6.25	Vis 6.25	Schraube 6.25	Tornillo 6.25
4	27.57510.000	4		Rondella	Washer	Rondelle	U.Scheibe	Arandela
5	22.31980.000	8		Molla a tazza	Belleville spring	Ressort à godet	Tassenfeder	Muelle de taza
7	13.62251.000	4		Distanziale	Spacer	Entretoise	Distanzstück	Distanciadór
8	007.41.114.00.00	1		Flap 21x25	Bead 21x25	Flap 21x25	Felgenband 21x25	Cinta tapa radios "flap" 21x25
9	007.41.113.00.00	32		Nipples	Nipples	Nipples	Nippel	Nipples
10	007.41.111.00.00	32		Raggio 3.256	Spoke 3.256	Rayon 3.256	Speiche 3.256	Radio 3.256
12	007.41.050.00.00	1		Cerchio 21.1,6-32 foro 8,5	Rim 21.1,6-32 foro 8,5	Jante roue 21.1,6-32 foro 8,5	Felge 21.1,6-32 foro 8,5	Aro 21.1,6-32 foro 8,5
13	007.35.061.00.00	1		Tampone in gomma	Rubber pad	Tampon en caoutchouc	Gummipuffer	Silent-block de goma
14	007.41.003.00.00	1		Distanziale interno	Inner spacer	Entretoise interne	Inneres Distanzstück	Distanciadór interior
15	12.97900.000	2		Cuscinetto 61904	Bearing 61904	Roulement 61904	Lager 61904	Cojínete 61904
16	007.41.030.00.00	1		Perno ruota anteriore	Front wheel spindle	Pivot roue AV.	Vorderradzapfen	Perno ruoda delantera
17	13.39279.000	1		Disco freno ant.	Front brake disk	Disque frein avant	Vorderbrems Scheibe	Disco freno delantero
18	007.41.201.00.58	1		Ruota anteriore	Fr.wheel	Roue AV.	Vorderrad	Rueda delantera
19	007.35.060.00.00	1		Contakm digitale	Speedometer	Compteur	Tachometer	Cuenta km. tr.
20	15.17500.000	1		Fermafascioni	Tire fastener	Caoutchouc serrure chambre	Reifen Halter	Agarre cubierta ant.
21	007.41.001.80.59	1		Mozzo anteriore c/cuscinetti	Front hub with ballbearing	Moyeu avant avec roulements	Nabe vo.	Buje ant.c/cojínetes

Tav.42

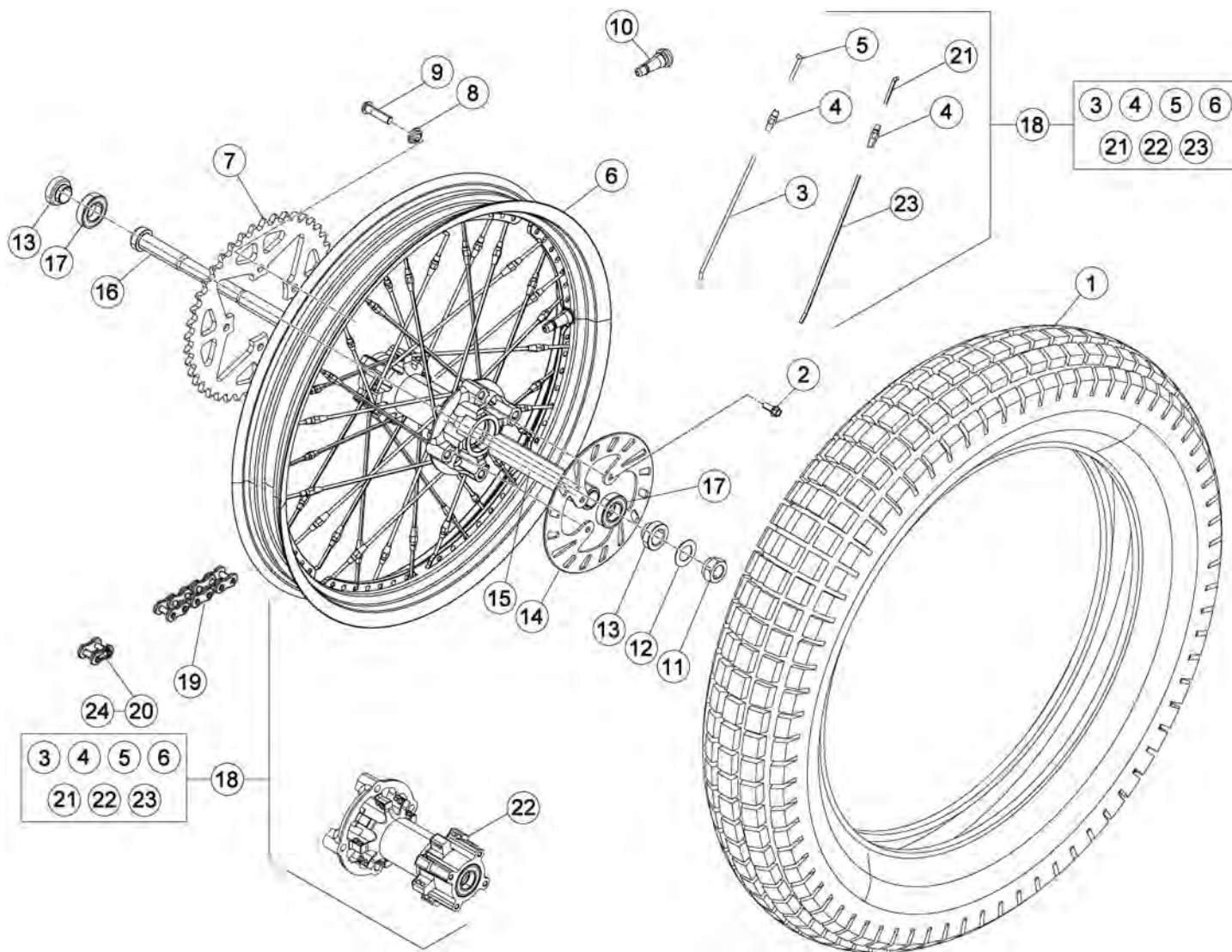

Tav.42

Pos Loc Pos Ps Pos	Numero Number Numé ro Número Nummer	Q.tà Q.ty Q.té M.ge C.ad	Nota Note Note Nota Anm.	Descrizione	Description	Dé signation	Beschreibung	Descrìpziò n
1	12.81470.000	1		Copertura 4,00.18 TR x-11 tbl	Cover 4,00.18 TR x-11 tbl	Couvercle 4,00.18 TR x-11 tbl	Abdeckung 4,00.18 TR x-11 tbl	Cubierta 4,00.18 TR x-11 tbl
2	007.42.016.00.00	4		Vite 6.16 dcro	Screw 6.16 dcro	Vis 6.16 dcro	Schraube 6.16 dcro	Tornillo 6.16 dcro
3	007.42.113.00.00	16		Raggio 3,5*175	Spoke 3,5*175	Rayon 3,5*175	Speiche 3,5*175	Radio 3,5*175
4	007.42.114.00.00	32		Nipples 3,5	Nipples 3,5	Nipples 3,5	Nippel 3,5	Nipples 3,5
5	007.42.117.00.00	16		Attacco raggio 3,5*35	Spoke fixing 3,5*35	Fixation du rayon 3,5*35	Speichebefestigung 3,5*35	Sujeció n radio 3,5*35
6	007.42.150.00.00	1		Cerchio ruota post.	Rear wheel rim	Jante roue AR.	Hinterradfelge	Llanta ruoda trasera
7	007.42.703.42.00	1	125cc	Corona z43	Ring gear z43	Couronne z43	Zahnkranz z43	Corona z43
7	007.42.702.42.00	1	200-250-300cc	Corona z42	Ring gear z42	Couronne z42	Zahnkranz z42	Corona z42
8	13.17123.000	4		Dado TECF M8	Nut TECF M8	Ecrou TECF M8	Mutter TECF M8	Tuerca TECF M8
9	007.42.015.00.00	4		Vite TBCE M8.33	Screw TBCE M8.33	Vis TBCE M8.33	Schraube TBCE M8.33	Tornillo TBCE M8.33
10	007.42.160.00.00	1		Valvola aria	Choke valve	Soupape air	Luftventil	Válvula aire
11	13.29602.000	1		Dado asse ruota post.	Rear wheel axle nut	Ecrou axe roue AR.	Mutter Hinterradachse	Tuerca eje rueda tras.
12	27.71210.000	1		Rondella 17x33x3	Washer 17x33x3	Rondelle 17x33x3	Scheibe 17x33x3	Arandela 17x33x3
13	007.42.020.00.00	2		Distanziale mozzo post.	Spacer rear hub	Entretoise moyeu arriere	Distanzscheibe	Dist. buje tras. der. l/corona
14	007.42.004.00.00	1		Disco freno post	Rear brake disk	Disque frein arrière	Hinterbrems Scheibe	Disco freno trasero
15	007.42.003.00.00	1		Distanziale interno	Inner spacer	Entretoise interne	Innere Distanzstück	Distanciadior interior
16	007.42.030.00.00	1		Perno ruota posteriore	Rear wheel pin	Pivot roue arrière	Hinterradbolzen	Perno ruoda trasera
17	12.98010.000	2		Cuscinetto 20x42x12 stagno	Ball bearing 20x42x12	Roulement 20x42x12 etanche	Kugellager 20x42x12	Cojinete 20.42.12 blindado
18	007.42.701.00.58	1		Ruota posteriore	Rear wheel	Roue AR.	Hinterrad	Rueda trasera
19	12.06771.000	1	125-200cc	Catena speciale 5/8.1/4 P.101	Special chain 5/8.1/4 P.101	Chaî ne spéciale 5/8.1/4 P.101	Spezialkette 5/8.1/4 P.101	Cadena especial 5/8.1/4 P.101
19	12.06770.000	1	250-300cc	Catena speciale 5/8.1/4 P. 100	Special chain 5/8.1/4 P. 100	Chaî ne spéciale 5/8.1/4 P. 100	Spezialkette 5/8.1/4 P. 100	Cadena especial 5/8.1/4 P. 100
20	22.11220.000	1		Maglia congiunzione	Connecting link	Maillon jonction	Kettenschloss	Enganche cadena
21	007.42.118.00.00	16		Attacco raggio 3,5*34	Spoke fixing 3,5*34	Fixation du rayon 3,5*34	Speichebefestigung 3,5*34	Sujeció n radio 3,5*34
22	007.42.001.80.59	1		Mozzo posteriore c/cuscinetti	Rear hub with ballbearing	Moyeu arriere avec roulements	Hinterrad Nabe	Buje del. c/cojinetes
23	007.42.112.00.00	16		Raggio 3,5*165	Spoke 3,5*165	Rayon 3,5*165	Speiche 3,5*165	Radio 3,5*165
24	22.11172.000	1	125-250-300cc	Maglia di giunzione -omolog.-	Connecting link -homolog.-	Maillon de liaison -homolog.-	Verbindungskettenglied -zulassung-	Eslabón de enganche -homologado-

Tav.43

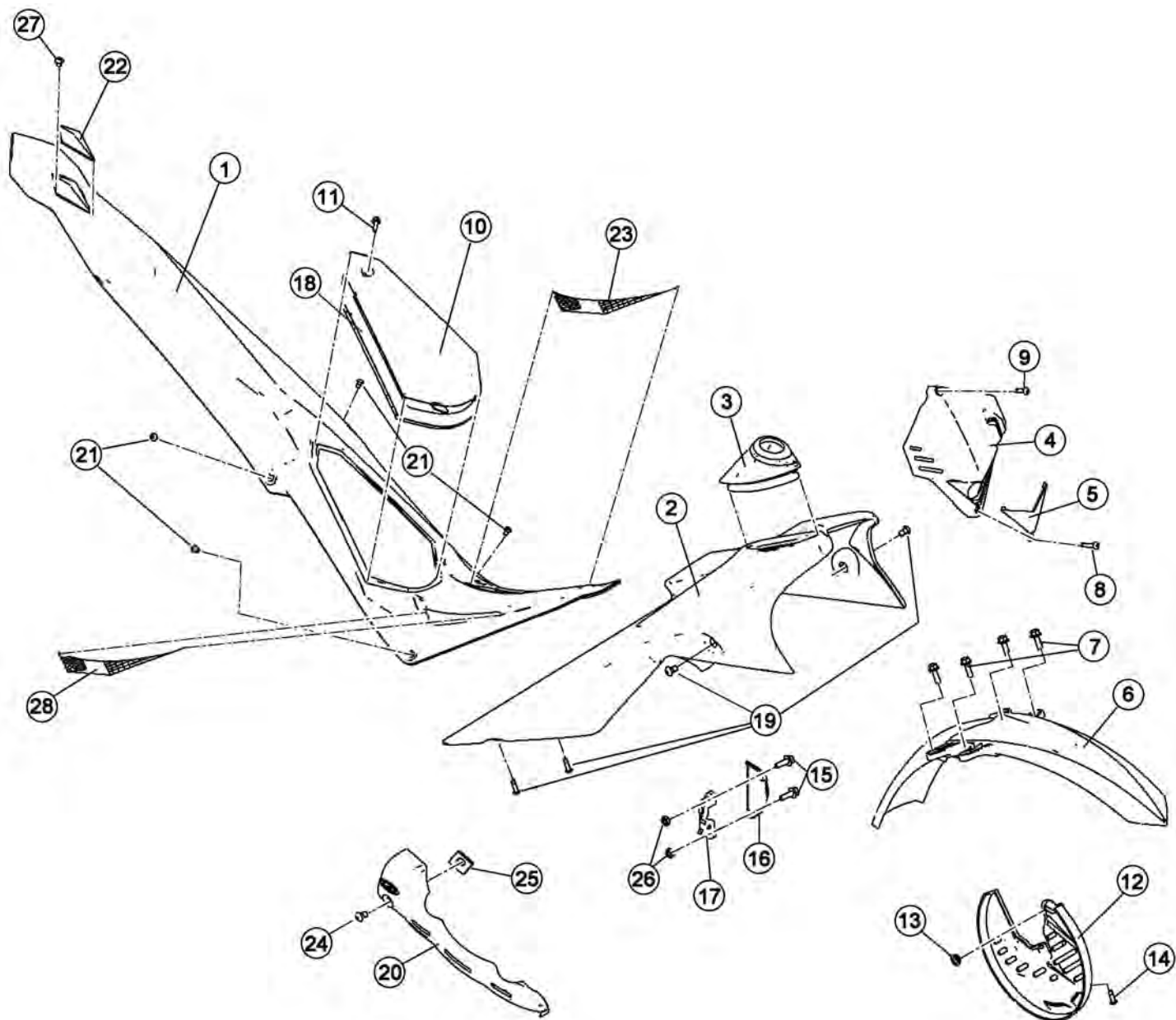

Tav.43

Pos Loc Ps Pos	Numero Number Numéro Nummer	Q.tà Q.ty Q.té M.ge C.ad	Nota Note Note Nota Anm.	Descrizione	Description	Dé signation	Beschreibung	Descrìpziò n
1	007.43.095.80.11	1		Parafango posteriore	Rear mudguard	Garde-boue AR.	Hinterradkotflü gel	Guardabarros tras.
2	007.43.015.10.11	1		Coperchio Serbatoio	Reservoir Lid	Couvercle De Ré servoir	Behälterdeckel	Calderi n Lid
3	007.43.101.00.00	1		Gommino passacavo	Fairlead rubber ring	Joint en caoutchouc passe-câ ble	Kabeldurchgangsgummi	Junta de goma pasa-cable
4	007.43.240.10.11	1		Mascherina EVO	Mask EVO	Masque EVO	Maske EVO	Má scara EVO
5	007.43.041.10.00	1		Mascherina portafaro	Headlight holder	Cache porte-phare	Lampenmaske	Portafaro ant. con adesivo
6	007.43.834.81.11	1		Parafango anteriore	Front mudguard	Garde boue AV.	Vorderradkotflü gel	Guardabarros anterior
7	11.48025.000	4		Bullone 6x16 ch 8 rs	Bolt 6x16 ch 8 rs	Boulon 6x16 ch 8 rs	Bolzen 6x16 ch 8 rs	Tornillo 6x16 ch 8 rs
8	31.96831.000	1		Vite TBCE 5.30	Screw TBCE 5.30	Vis TBCE 5.30	Schraube TBCE 5.30	Tornillo TBCE 5.30
9	31.96830.000	1		Vite TBCE 5.20	Screw TBCE 5.20	Vis TBCE 5.20	Schraube TBCE 5.20	Tornillo TBCE 5.20
10	007.43.093.10.11	1		Coperchio filtro aria	Air cleaner cover	Couvercle filtre à air	Lufifiltergehä use	Tapa filtro de aire
11	11.46360.000	1		Bullone flangiato M5x16	Head Flanged bolt M5x16	Boulon Bridé M5x16	Bundbolzen M5x16	Bulón con Brida M5x16
12	007.43.060.10.59	1		Copridisco anteriore	Disc cover	Couvre-disque	Scheibenabdeckung	Cubredisco
13	13.55240.000	1		Distanziale	Spacer	Entretoise	Distanzstück	Distanciator
14	31.29860.000	1		Vite M5x16 TTLIC	Screw M5x16 TTLIC	Vis M5x16 TTLIC	Schraube M5x16 TTLIC	Tornillo M5x16 TTLIC
15	31.30020.000	2		Vite M5x25 TCCE	Screw M5x25 TCCE	Vis M5x25 TCCE	Schraube M5x25 TCCE	Tornillo M5x25 TCCE
16	007.43.051.10.59	1		Supporto bobina sup.	Upper coil bracket	Support bobine sup.	Ankerplatte Obere, kpl	Soporte bobinas sup.
17	007.43.050.10.59	1		Supporto bobina Inf.	Lower coil bracket	Support bobine inf.	Ankerplatte Untere, kpl	Soporte bobinas inf.
18	007.38.021.00.00	1		Guarnizione coperchio filtro	Filter cover gasket	Joint couvercle filtre	Dichtung Filterabdeckung	Junta tapa filtro
19	31.29826.000	4		Vite 5x10 TBCEI	Screw 5x10 TBCEI	Vis 5x10 TBCEI	Schraube 5x10 TBCEI	Tornillo 5x10 TBCEI
20	007.43.013.10.59	1		Coperchio Cablaggio	Harness Cover	Couvercle Cablage	Vergaser Abdeckung	Tapa Carburador
21	31.95510.000	4		Vite TBCE M6x12	Screw TBCE M6x12	Vis TBCE M6x12	Schraube TBCE M6x12	Tornillo TBCE M6x12
22	15.01823.053	1		Fanalino posteriore	Rear combination lamp	Feu AR.	Rücklicht	Piloto
23	007.43.092.00.50	1		Griglia sx. parafango post.	LH rear mudguard grille	Calandre G. garde boue AR.	Grill links Hinterradkotflü gel	Reja izq. guardabarros tras. der.
24	31.29810.000	1		Vite 5x12	Screw 5x12	Vis 5x12	Schraube 5x12	Tornillo 5x12
25	25.58060.000	1		Clip M5	Clip M5	Clip M5	Clip M5	Clip M5
26	13.11000.000	2		Dado M5	Nut M5	Ecrou M5	Mutter M5	Tuerca M5
27	31.22550.000	1		Vite 2,9.10 TCIC	Screw 2,9.10 TCIC	Vis 2,9.10 TCIC	Schraube 2,9.10 TCIC	Tornillo 2,9.10 TCIC
28	007.43.091.00.50	1		Griglia dx. parafango post.	RH rear mudguard grille	Calandre D. garde boue AR.	Grill rechts Hinterradkotflü gel	Reja der. guardabarros tras. der.

Tav.43A

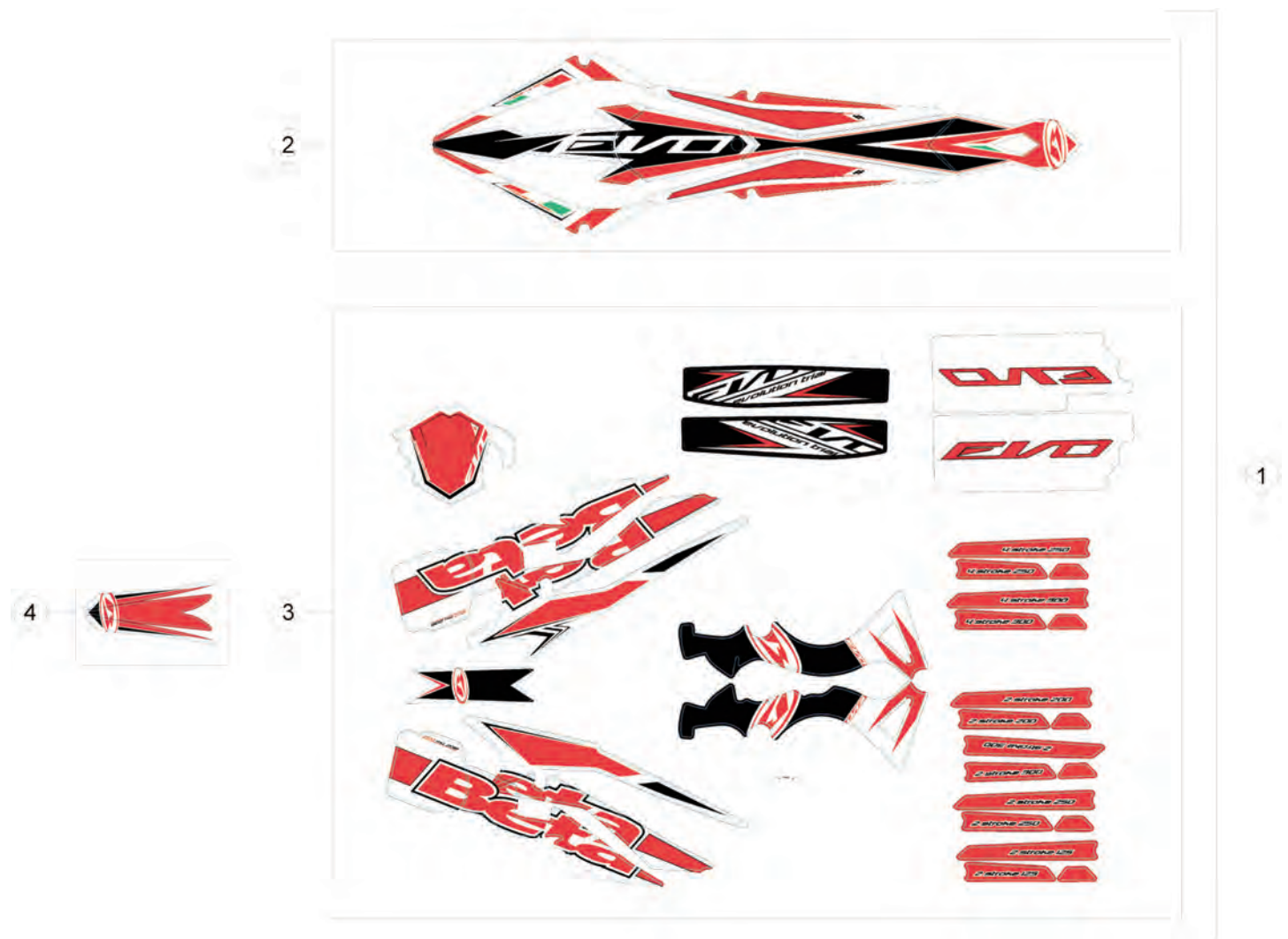

Pos Loc	Numero Number	Q.tà Q.ty	Nota Note	Descrizione	Description	Dé signation	Beschreibung	Descrìpziòn
Pos	Numéro	Q.té	Note					
Ps	Número	M.ge	Nota					
Pos	Nummer	C.ad	Anm.					
1	007.43.833.82.00	1		Kit decalco completo	Trimmings kit, assy	Jeu enjoliv. Complet	Abziehbildsatz, kpl.	Juego calcom. compl.
2	007.43.828.82.00	1		Decalco parafango post.	Rear mudguard sticker	Dé calcomanie garde boue AR.	Hinterradkotflü gel Kleber	Pega guardabarros trasero
3	007.43.832.82.00	1		Decalco completamento	Completion decals kit	Kit compl. Decalco	Satz Kleber rahmen	Kit adhesivos para completar.
4	007.43.831.82.00	1		Decalco parafango ant.	Front mudguard sticker	Dé calcomanie garde boue AV.	Vorderradkotflü gel Kleber	Pega guardabarros delantero

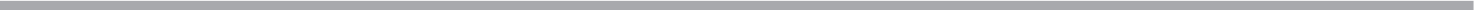

Handwriting practice area consisting of 20 horizontal dotted lines.



