

SPAREPARTSCATALOG

CHASSIS

ART.-NR.: 3CFF247501EN

FC 450 US 2015

FRONT FORK, TRIPLE CLAMP

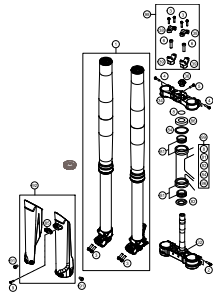

4

FRONT FORK DISASSEMBLED

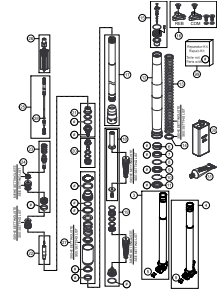

5

HANDLEBAR, CONTROLS

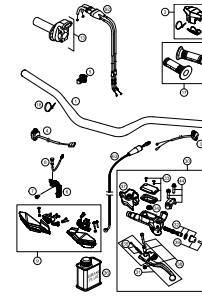

6

FRAME

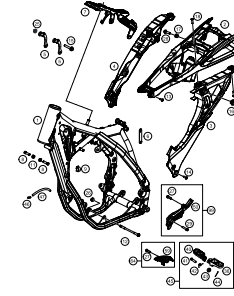

7

SHOCK ABSORBER

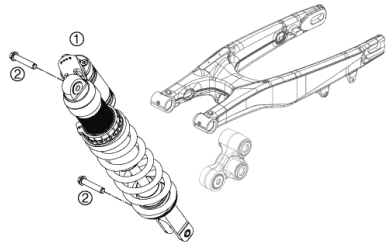

8

SHOCK ABSORBER DISASSEMBLED

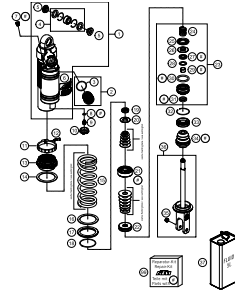

9

PRO LEVER LINKING

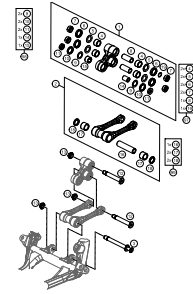

11

SWING ARM

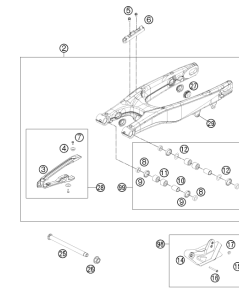

12

EXHAUST SYSTEM

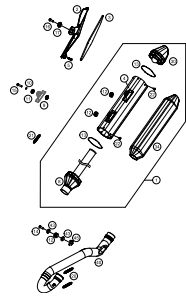

13

AIR FILTER

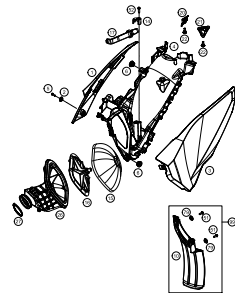

14

TANK, SEAT, COVER

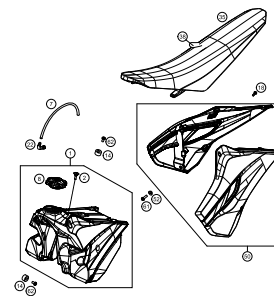

15

FUEL PUMP

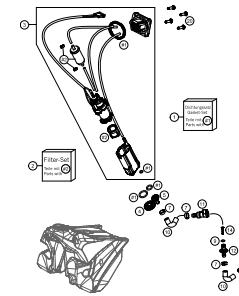

16

MASK, FENDERS

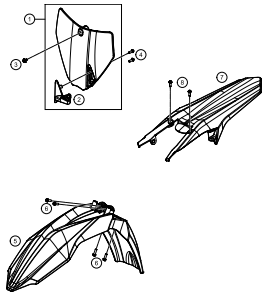

17

DECAL

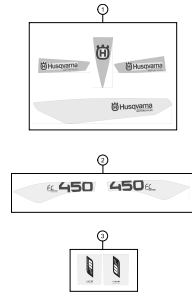

18

FRONT WHEEL

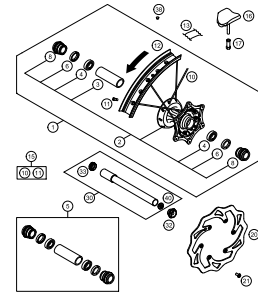

19

REAR WHEEL

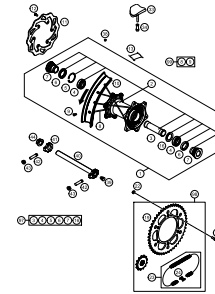

20

WIRING HARNESS

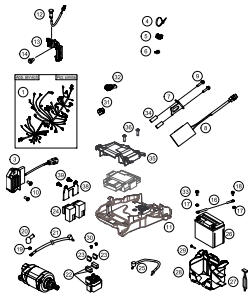

21

HAND BRAKE CYLINDER

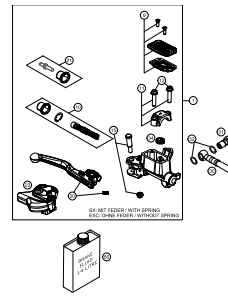

22

REAR BRAKE CONTROL

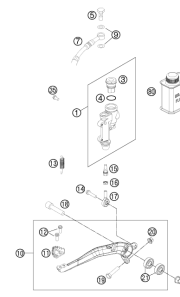

23

BRAKE CALIPER FRONT

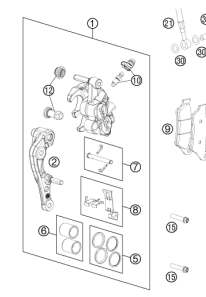

24

BRAKE CALIPER REAR

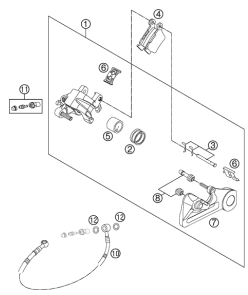

25

ACCESSORIES KIT

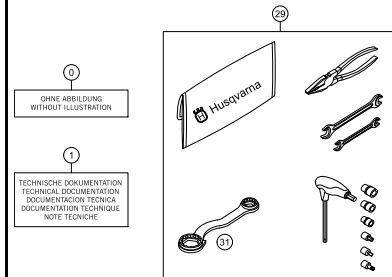

26

WP SHIMS FOR SETTING

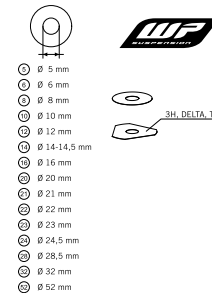

27

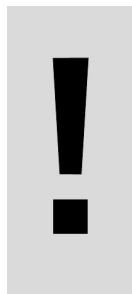

All information contained is without obligation. HUSQVARNA MOTORCYCLES GmbH particularly reserves the right to modify any equipment, technical specifications, prices, colors, shapes, materials, services, service work, constructions, equipment and the like so as to adapt them to local conditions or to cancel any of the above items, all without previous announcement and without giving reasons. KTM may stop manufacturing certain models without previous notice. HUSQVARNA MOTORCYCLES shall not be held liable for any deviations of availability and/or ability to deliver, illustrations, descriptions, printing and/or other errors. The illustrated models partly contain extra equipment, which is not applied to standard models.

© by HUSQVARNA MOTORCYCLES GmbH, Mattighofen AUSTRIA; All rights reserved; Reprint, also in extracts, with written allowance of HUSQVARNA MOTORCYCLES GmbH, Mattighofen only.

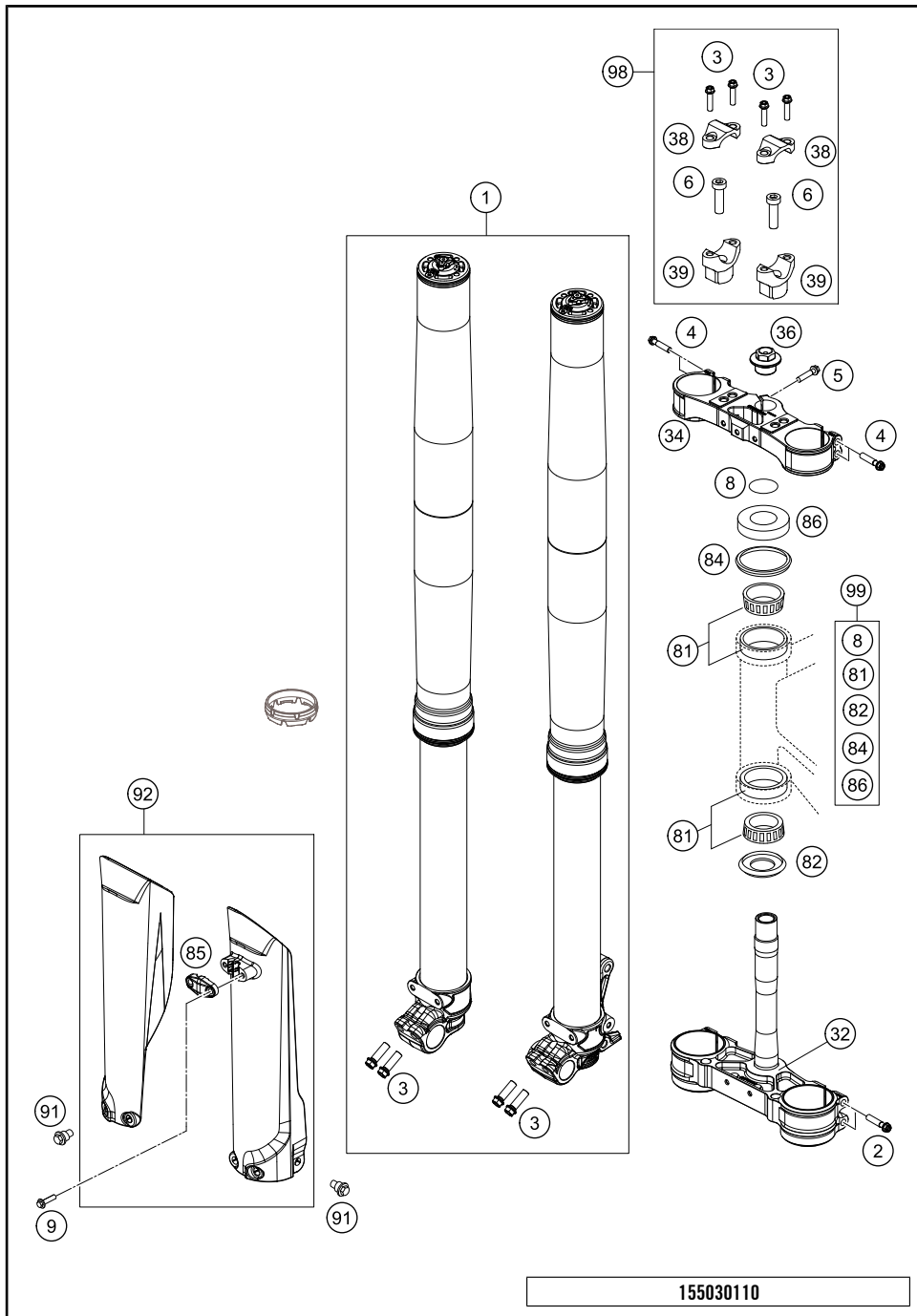

POS	PARTNUMBER	PARTNAME	PIECE
1	2418705701	FORK 350/450 SX-F US 15	1
2	0025080506	HH COLLAR SCREW M8X50 TX40	4
3	0025080256	HH COLLAR SCREW M8X25 TX40	8
4	0025080406	HH COLLAR SCREW M8X40 TX40	4
5	0025080256S	HH COLLAR SCREW M8X25 TX40	1
6	0032100356S	AH-COLLAR SCREW M10X35 ISA45	2
8	0770025035	O-RING 25X3,55 NBR70 05	1
9	0017060206	SCREW F. PLASTIC K60X20AL SW6	2
32	7770103202230	TRIPLE CL. BOTT. CPL. X=22 BL.	1
34	7770103402230	TRIPLE CLAMP TOP X=22 BLACK	1
36	70009082000	AXLESCREW M20X1.5; SW17	1
38	77201038000	HANDLEBAR CLAMP 28MM	2
39	59401039032	HANDLEB.SUPP. D=28MM H=32MM 05	x
39	59401039037	HANDLEB.SUPP. D=28MM H=37MM 05	2
39	59401039042	HANDLEB.SUPP. D=28MM H=42MM 05	x
81	54201081100	TAPERED ROLLER BEARING CPL. 06	2
82	77701084000	O-RING SUPPORT W. SEALING LIP	1
84	54601184000	STEERING HEAD GASKET TOP	1
85	77701085000DA	CLAMP BRAKE HOSE	1
86	78101086000	STEERING HEAD COVER	1
91	59001092050	SPECIAL SCREW M6X12,5 WS=8	6
92	77701094000DA	FORK PROTECTION L/S+R/S	1
98	00050000921	HANDLEBAR SUPPORT KIT D28/H37	x
99	00050000930	STEERING HEAD REP. KIT 06-15	x

155030110

C158130117

* NEW PART X ON DEMAND

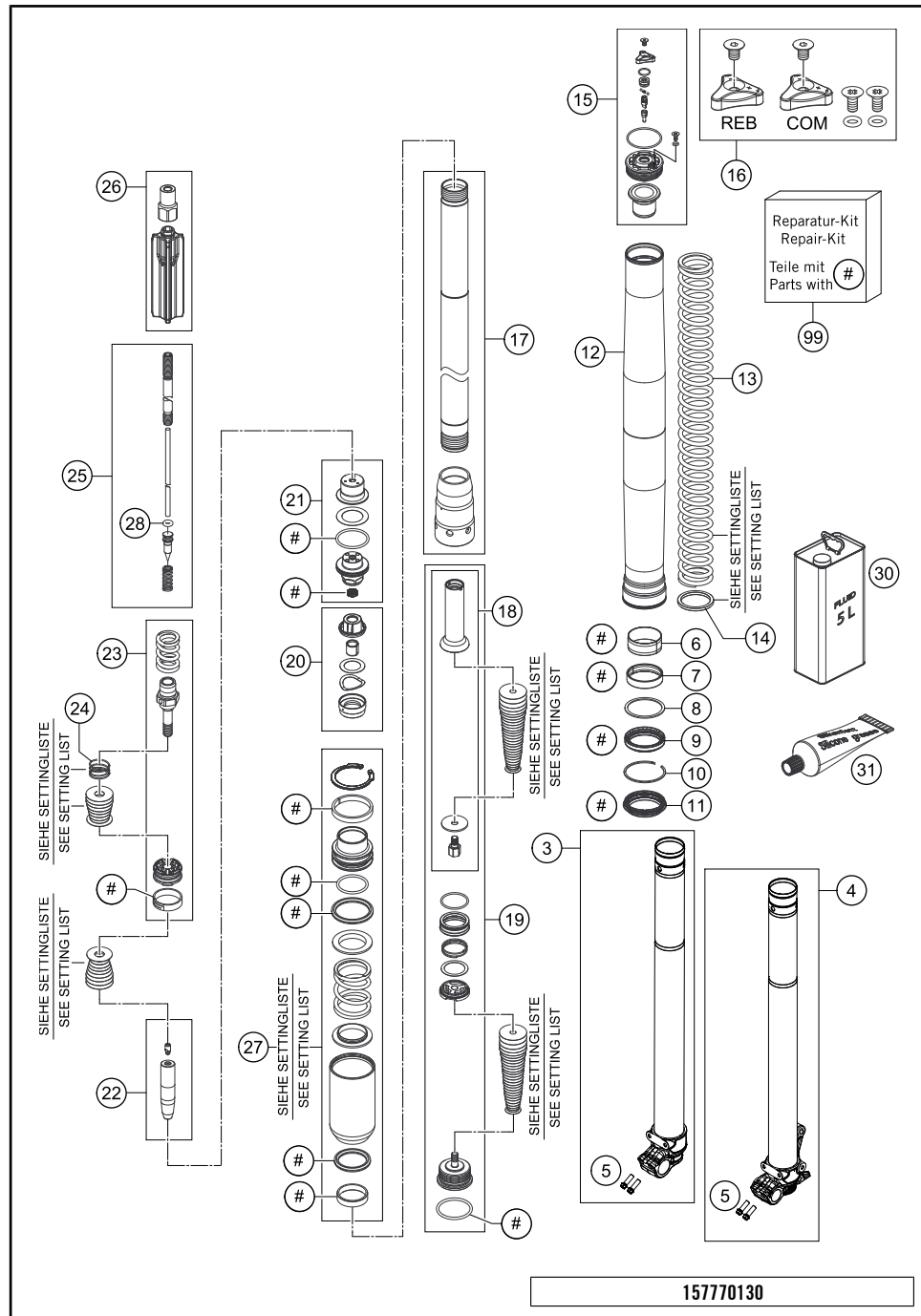

POS	PARTNUMBER	PARTNAME	PIECE
3	48601327S1	AXLE CLAMP R/S WITH INNER TUBE	1
4	48601326S1	AXLE CLAMP L/S WITH INNER TUBE	1
5	0025080256	HH COLLAR SCREW M8X25 TX40	4
6	48601008	GUIDING BUSH 47X49X20 R11	2
7	48601009	GUIDING BUSH 48X52X12 R11	2
8	48600013	SUPPORT RING 50 X 57,6 X 1,5	2
9	48601179	OIL SEALRING D48X57,9X11,4 RED	2
10	48600070	LOCK WASHER SB58	2
11	48601178	DUST SEAL DL48X58,4X5,7 RED	2
12	48600736	OUTER TUBE L577 D54/60MM 2L	2
13	91410100S	SPRING 4,0N/MM SET D=4,9MM	x
13	91410101S	SPRING 4,2N/MM SET D=4,9MM	x
13	91410102S	SPRING 4,4N/MM SET D=4,9MM	x
13	91410103S	SPRING 4,6N/MM SET D=4,9MM	x
13	91410104S	SPRING 4,8N/MM SET D=4,9MM	x
13	91410105S	SPRING 5,0N/MM SET D=4,9MM	x
14	48600456	SPACER 43X35X2,5	x
14	48600458	SPACER 43X35X1,5	x
15	48601116E	SCREW CAP M51X1,5 CPL.	1
15	48601050E	SCREW CAP M51X1,5 REB. KPL.	1
16	R14033	SCREW CAP SMALL PART KIT	1
17	48601031S	CARTRIDGE KIT	2
18	R14044	HYDROSTOP KIT	2
19	48601403S	BASE VALVE KIT	2
20	48601025S1	CHECK VALVE D21 CPL.	2
21	R14035	SCREW SLEEVE KIT	2
22	48601123S	NEEDLE KIT	2
23	R14045	TAP KIT	2
24	48600382	SHUTTLE VALVE SPRING C=0,4	2
25	48601343S	PISTON ROD CPL.	2
26	48601035S1	SPRING GUIDE CPL.	2
27	48601315S1	PRESSURE TANK FOR 24187073 CPL	x
27	48601315S2	PRESSURE TANK FOR 24187051 CPL	x
27	48601315S3	PRESSURE TANK FOR 24187057 CPL	x
28	46811265	O-RING VITON 2,2X1,6	2
30	48601166S1	FORK OIL SAE4 5L	1
31	T511	SILICONE GREASE F. DUST STRI	1
99	R24001	REPAIR - KIT	x

157770130

C15770130

* NEW PART X ON DEMAND

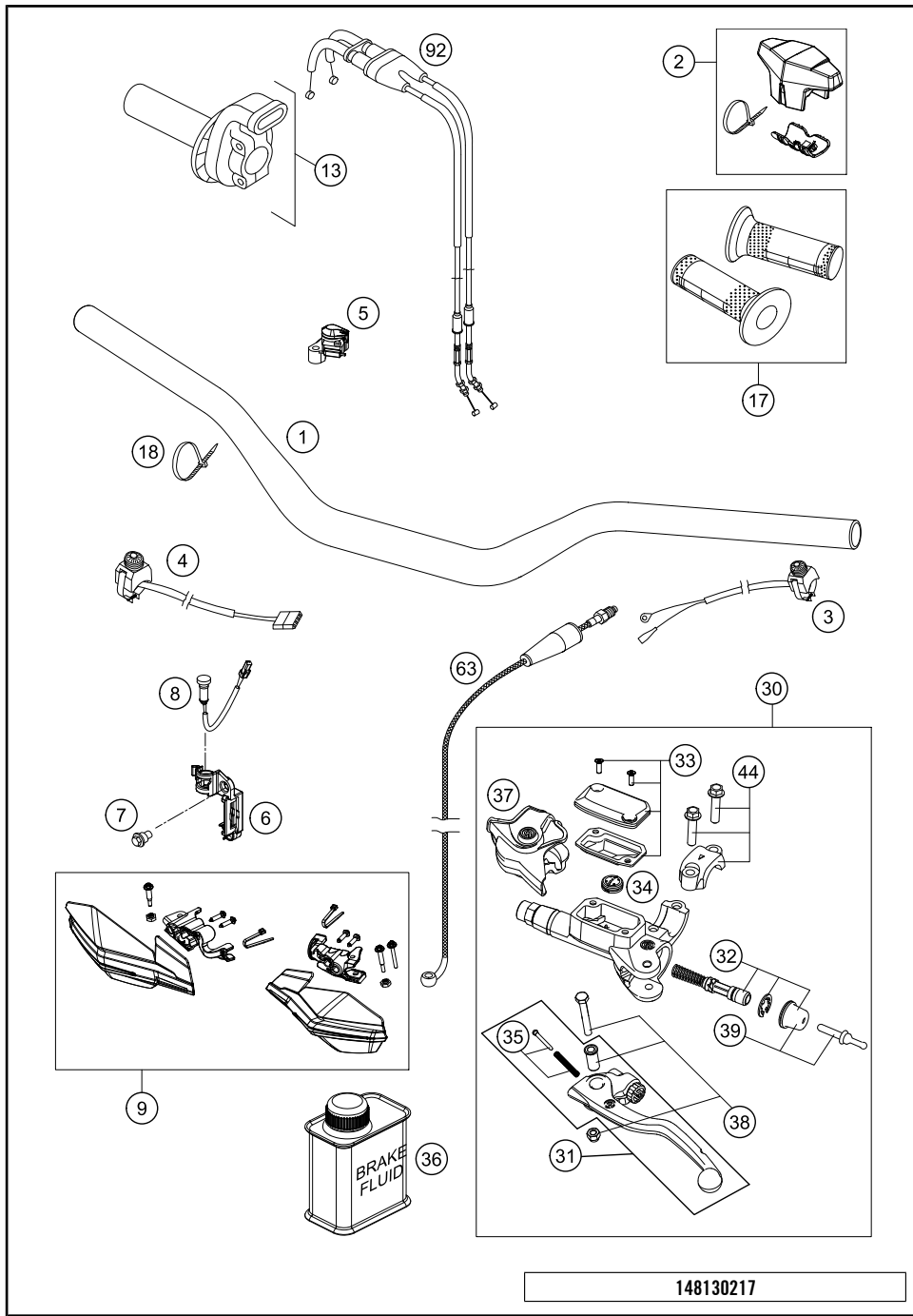

POS	PARTNUMBER	PARTNAME	PIECE
1	7770200110030	HANDLEBAR BLACK	1
2	80302602144	BAR PAD 2015	1
3	50311089200	SHORT CIRCUIT BUTTON 02	1
4	78111074000	STARTER BUTTON GREY 13	1
5	77239974100	MAP SWITCH SET	1
6	77214098000	HOLDER INDICATOR LIGHT SX	1
7	59001092050	SPECIAL SCREW M6X12,5 WS=8	1
8	81214083000	INDICATOR LIGHT LED YELLOW FI	1
9	7770217900028	HAND GUARDS CPL. L/S+R/S WHITE	1
13	78102010000	THROTTLE GRIP CPL.	1
17	80302021000	GRIP SET BLACK/WHITE	1
18	44011076200	CABLE TIE 200/3,6MM BLACK	x
18	44011076140	CABLE TIE 140/2,5MM BLACK	x
30	54802030144	MASTER CYLINDER CPL.	1
31	54802031000	CLUTCH LEVER CPL. BREMBO 06	1
32	54802032000	REP. KIT PISTON 06	1
33	5480200310030	COVER HYD. CLUTCH CPL. 2014	1
34	54802051000	VALVE	1
35	54802052000	BOLT KPL.	1
36	00062030000	BRAKE FLUID DOT5.1 0,25L	1
37	54802037000	PROTECTION CAP 06	1
38	54802038100	LEVER SCREW CPL. 06	1
39	54802046000	PUSH ROD CPL.	1
44	54802005100	CLAMP CPL. 06	1
63	54832063000	CLUTCH PIPE 06	1
92	78102091000	THROTTLE CABLE 4ST. 13	1

148130217

C158130223

* NEW PART X ON DEMAND

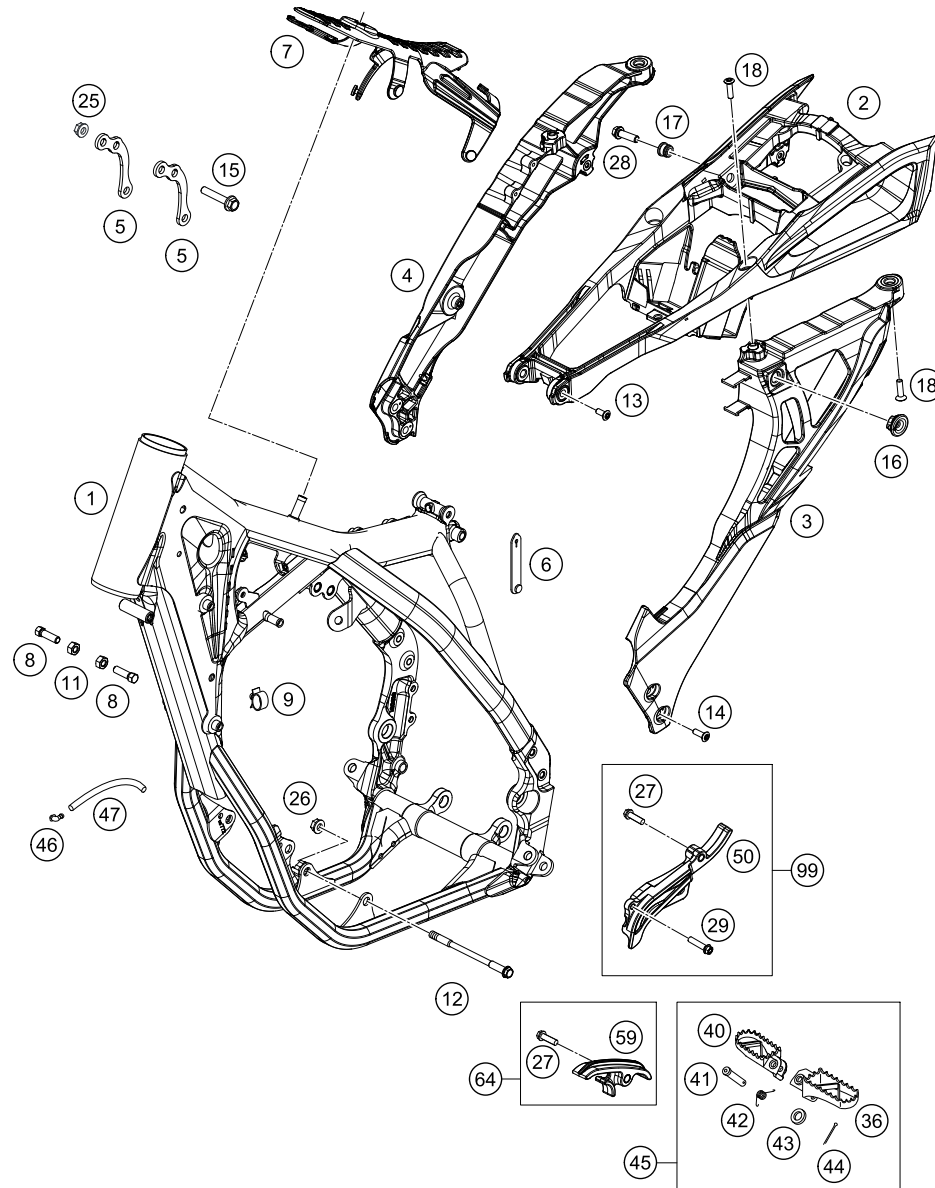

158130313

POS	PARTNUMBER	PARTNAME	PIECE
1	8130360100028	FRAME 450 FC 2014	1
2	8130310201049	SUBFRAME UPPER PART	1
3*	8130310202049	SUBFRAME LEFT PART	1
4	8130310203049	SUBFRAME RIGHT PART	1
5	78903013000	REINFORCING	2
6	60011093075	RUBBER CABLE TIE 75MM 03	1
7	77207012000	TANK REST RUBBER	1
8	59001037000	SPECIAL SCREW M8X26 WS=10	2
9	57013072100	WIRING HOLDER 16MM	1
11	0934080003	HEXAGON NUT DIN0934-M 8	2
12	59003013000	ENGINEBRAC.SCREW M10X123 WS=13	2
13	0035080306S	AH-COLLAR SCREW M8X30 ISA45	2
14	0035080206S	AH-COLLAR SCREW M8X20 ISA45	4
15	56530079000S	HH COLLAR SCREW M8X44 WS13	3
16	47106003160	QUICK CONNECTOR CLUTCH	2
17	81303002011	SPACER BUSHING 12X9X6,2	2
18	0019080306S	COUNTER-SUNK SCREW ISA45 M8X30	4
25	06923080003	HEXAGON NUT DIN EN1661 M8 SW13	3
26	54310086100	SELF LOCKING NUT M10 CU WS=14	2
27	0025080306	HH COLLAR SCREW M8X30 TX40	2
28	0025060206	HH COLLAR SCREW M6X20 TX30	2
29	0025060306	HH COLLAR SCREW M6X30 TX30	1
36	78003040050	FOOTREST L/S 08	1
40	78003041050	FOOTREST R/S 08	1
41	54803044000	PIN FOR FOOT PED 51.5X9.8 MM	2
42	54603041000	FOOTREST SPRING L/S & R/S	2
43	0125100003	WASHER DIN0125-A10,5	2
44	0094032253	PIN DIN0094-3,2X25 STEEL	2
45	78003040033	FOOTREST L/S + R/S CPL. 09	1
46	50303089000	ANGLE PIECE '97	2
47	55007016001	PVC-HOSE 7X10 PER METER	0
50	78103096000	CHAIN GUARD 450/500 EXC 12	1
59	77203053000	CHAIN SLIDER LOWER PART CPL.	1
64	77203053010	CHAIN SLIDING KIT BELOW CPL.11	1
99	78103096010	SPROCKET COVER KIT	x

C158130322

* NEW PART

X ON DEMAND

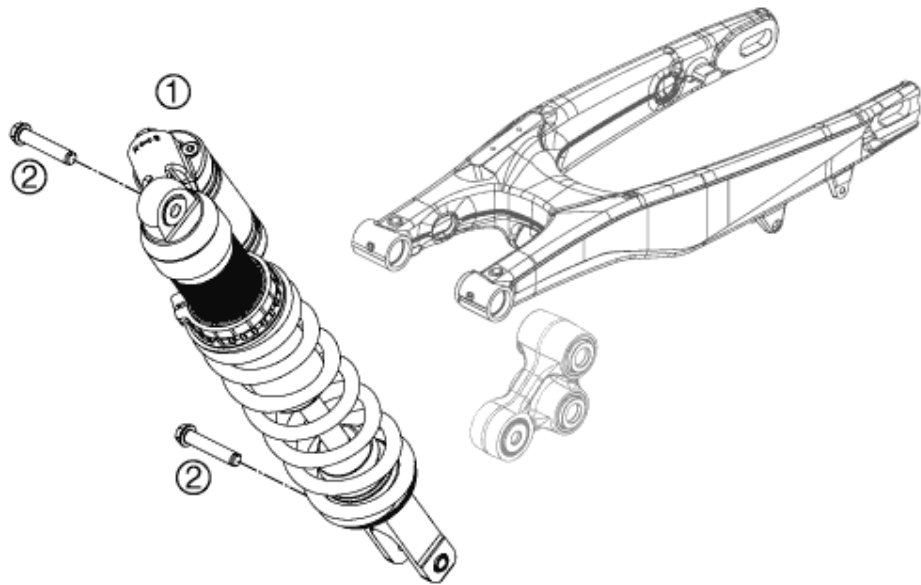

POS	PARTNUMBER	PARTNAME	PIECE
1	1818705901	MONOSHOCK 450 SX-F USA	1
2	77204089000	HH COLLAR SCREW M10X52 SW13	2

117710410

C158130412

* NEW PART

X ON DEMAND

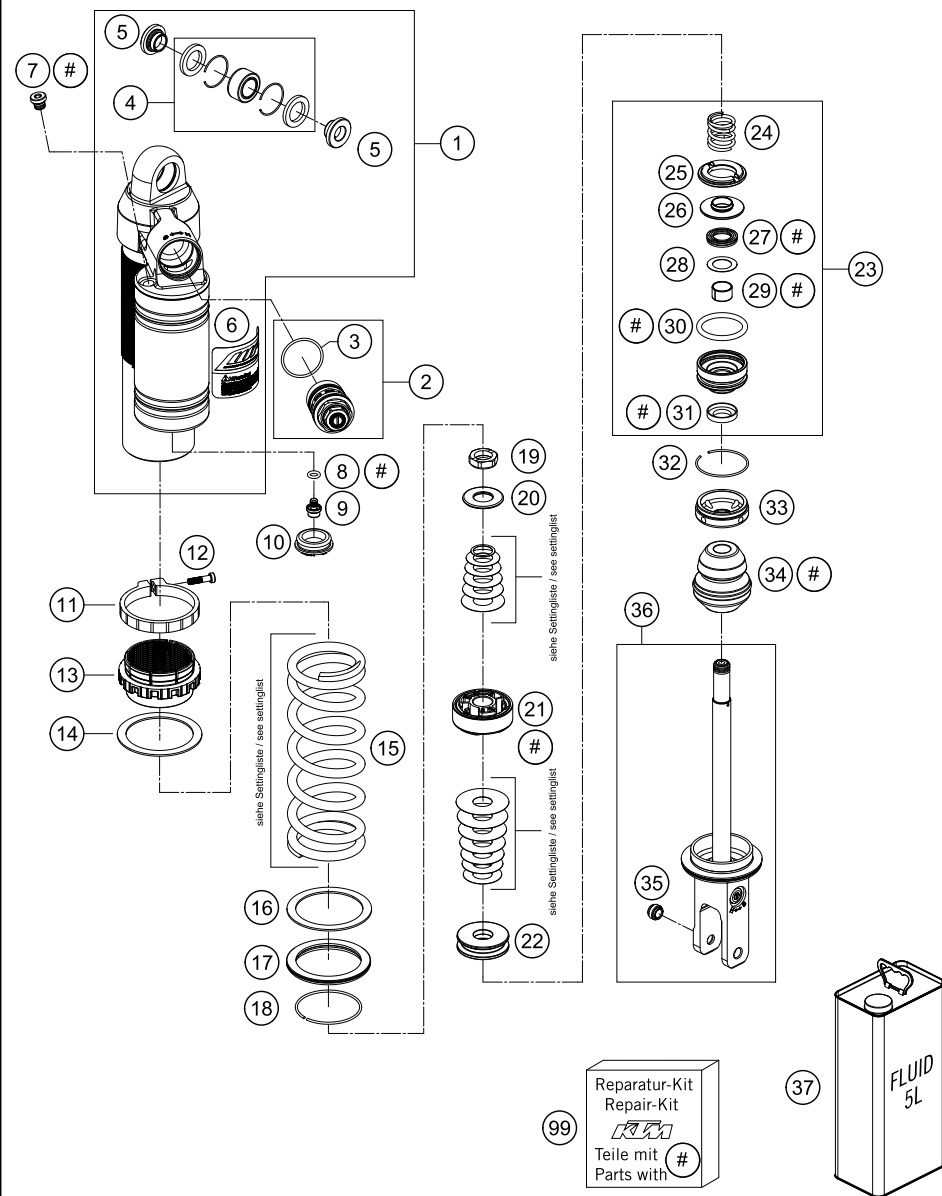

POS	PARTNUMBER	PARTNAME	PIECE
1	50180944S1	MONOSHOCK UPPER PART CPL.	1
2	50180213S21	DCC COMPR. DAMP. CON. CPL. 13	1
3	50180218	O-RING 25X1,5 VITON	1
4	R12012	REP. KIT BEAR./SEAL UP. 07	1
5	46180010	BUSH KGW 10X24	2
6	52000087	STICKER WP MONOSHOCK	1
7	50180095	BLEED PLUG R 1/8	1
8	46810893	O-RING NBR 5,28X1,78	1
9	36120151	SCREW PLUG M5X6	1
10	46811208	RUBBER CAP "DO NOT OPEN"	1
11	50180937	TENSIONING RING D64 H10	1
12	14460042	%ALLENHEAD SCREW M5 L=20 STAIN	1
13	50180938	ADJUSTING NUT PLASTIC	1
14	50180114	SPACER RING FOR SPRING	1
15	91210100S	SPRING 260 45 N/MM	x
15	91210101S	SPRING 260 48 N/MM	x
15	91210102S	SPRING 260 51 N/MM	x
15	91210103S	SPRING 260 54 N/MM	x
15	91210104S	SPRING 260 57 N/MM	x
15	91210105S	SPRING 260 60 N/MM	x
16	50180793	SPACER RING ADJUSTING NUT	1
17	50180824	VALVE SPRING D80 CLOSED	1
18	50180273	CIRCLIP 58,2X2	1
19	50180141	PISTON ROD NUT M16X1	1
20	50180836	REBOUND DISC 16X34 T2 H0	1
21	50180786E	PISTON D50	1
22	50180801	REBOUND DISC D16X43 H8	1
23	50180603SA	ADAPTER D50 H28 CPL.	1
24	50180780	REBOUND SPRING	1
25	50180798	REBOUND RUBBER	1
26	50180800	SPRING RING	1
27	50180605S	SEAL D18X30X5 08	1
28	50180604	SHIM D29,75 X D19 X T0,4 08	1
29	46180119	DU-BUSH 18X20X12	1
30	50180103	O-RING 41X5	1
31	50180606	DUST SEAL 1828 08	1
32	50180126	CIRCLIP 53X1,75	1
33	50180626	RESERVOIR CAP D=50 H=10 09	1

148130430

C157770430

* NEW PART

X ON DEMAND

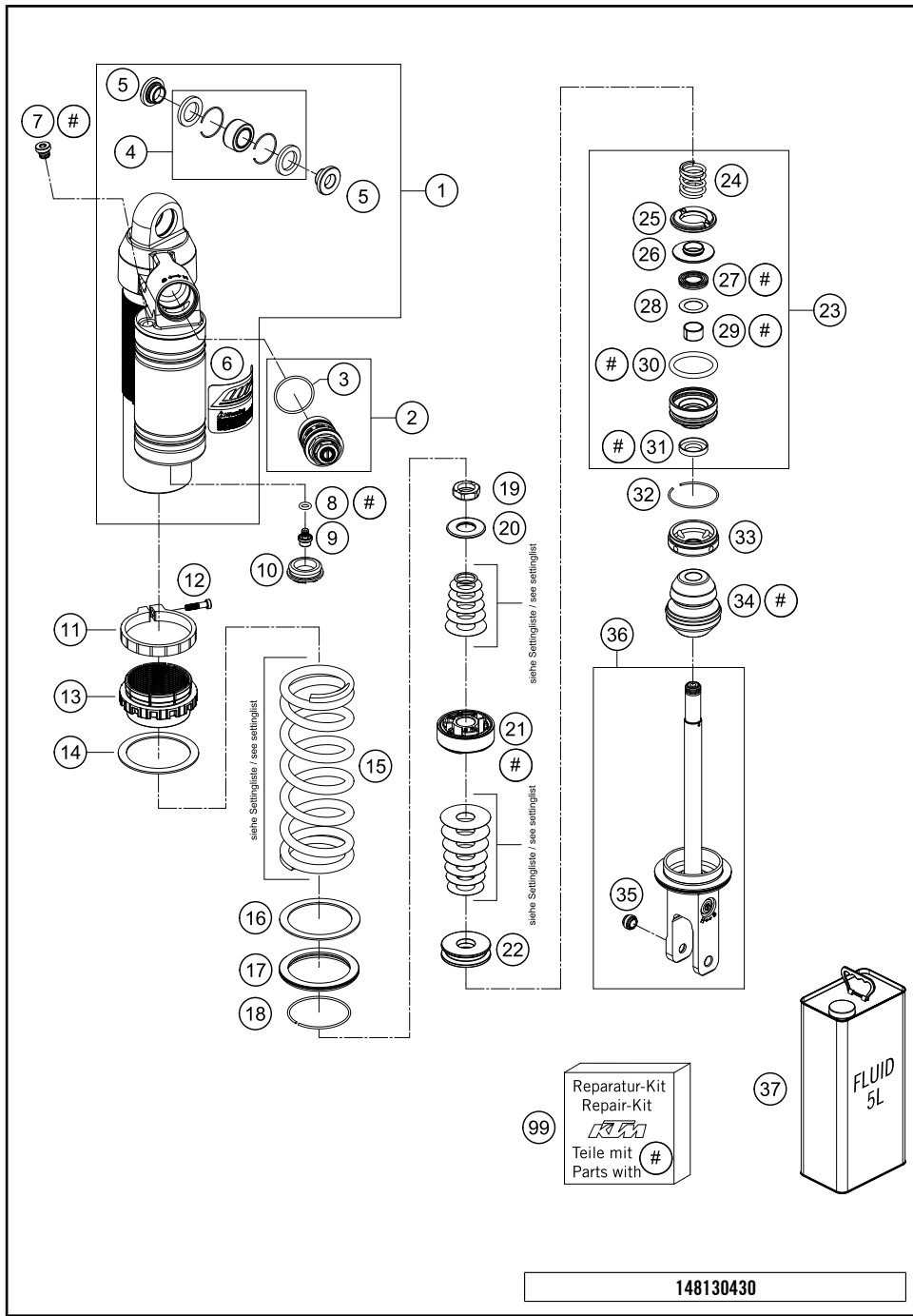

POS	PARTNUMBER	PARTNAME	PIECE
34	50180775	BUMP RUBBER	1
35	46811205	ADAPTOR-BUSH M10x1,50, D=15	1
36	50180773SA1	MONOSHOCK BOTTOM PART CPL.	1
37	50180751S1	SHOCK ABSORBER FLUID 5 LT	1
99	R12018	REPAIR-KIT	x

148130430

C157770430

* NEW PART X ON DEMAND

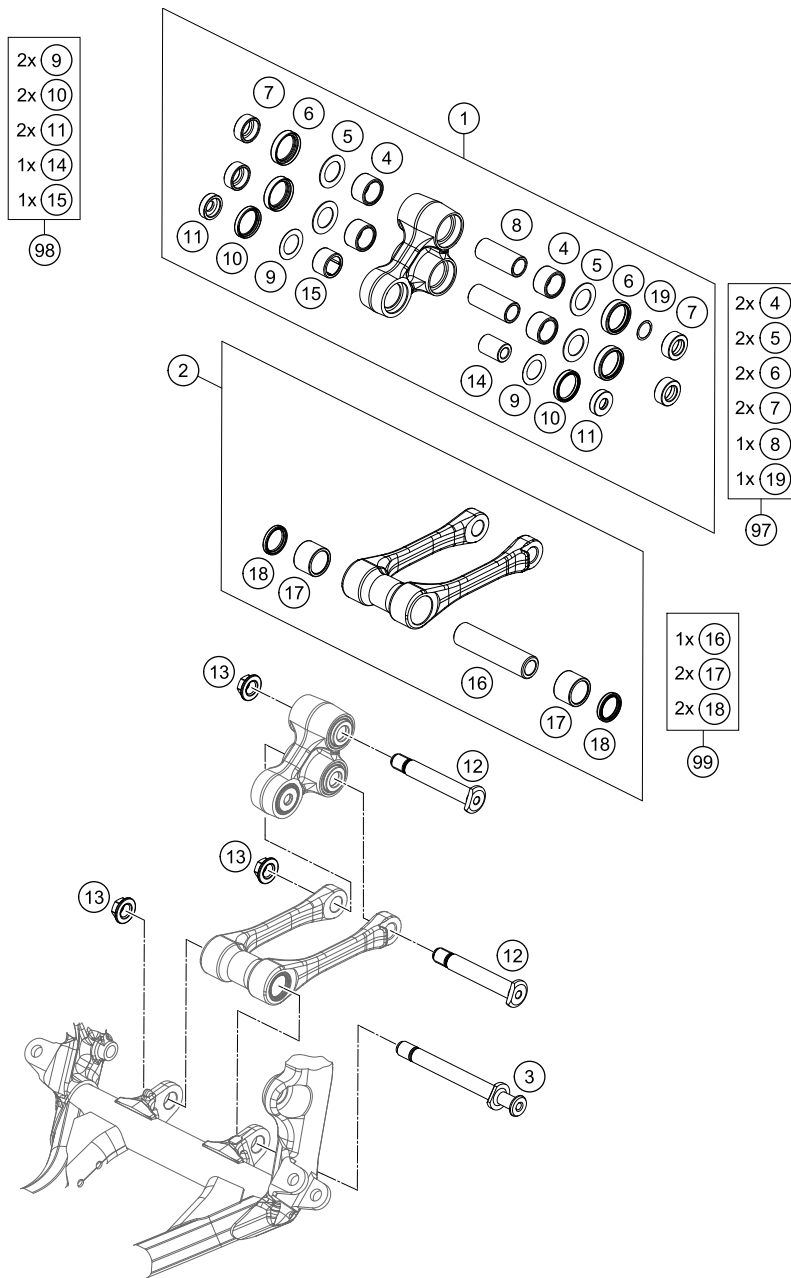

POS	PARTNUMBER	PARTNAME	PIECE
1	7770408004401	TRIANGLE LEVER CPL. SX 2014	1
2	7770408304401	PULL ROD CPL. SX 15	1
3	77204084000	PULL ROD ANCHOR BOLT	1
4	54603097000	NEEDLE BUSH HK 2016	4
5	59033080000	SHIM 20X32X1	4
6	0760253270	SHAFT SEAL RING 25X32X7	4
7	77204080130	BUCKET SHAFT SEAL RING 25X11	4
8	54603081000	BUSHING SLEEVE 15 X 20 X 48	2
9	50180604	SHIM D29,75 X D19 X T0,4 08	2
10	0760243050	SHAFT SEAL RING 24X30X5	2
11	77204080020	BUCKET FOR SHAFT SEAL RING	2
12	77204085000	BOLT FOR CANTILEVER M14	2
13	77204087000	HEX NUT M14X1.5 SW17	3
14	77204080010	BEARING SLEEVE 10X18X25,5	1
15	0618182416	NEEDLE BUSH HN1816 RS 18/24/16	1
16	77204084010	BEARING SLEEVE	1
17	0618222820	NEEDLE BEARING HK2220 22X28X20	2
18	0760222841	SHAFT SEAL RING G22x28x4	2
19	54603090010	STEEL WASHER 15,2X19X0,1	x
19	54603090020	STEEL WASHER 15,2X19X0,2	x
19	54603090030	STEEL WASHER 15,2X19X0,3	x
97	77204080110	TRIANGLE LEVER REP. KIT REAR	x
98	77204080090	TRIANGLE LEVER REP. KIT FRONT	x
99	77204083010	PULL ROD REP. KIT SX/SX-F	x

147890460

C158130462

* NEW PART

X ON DEMAND

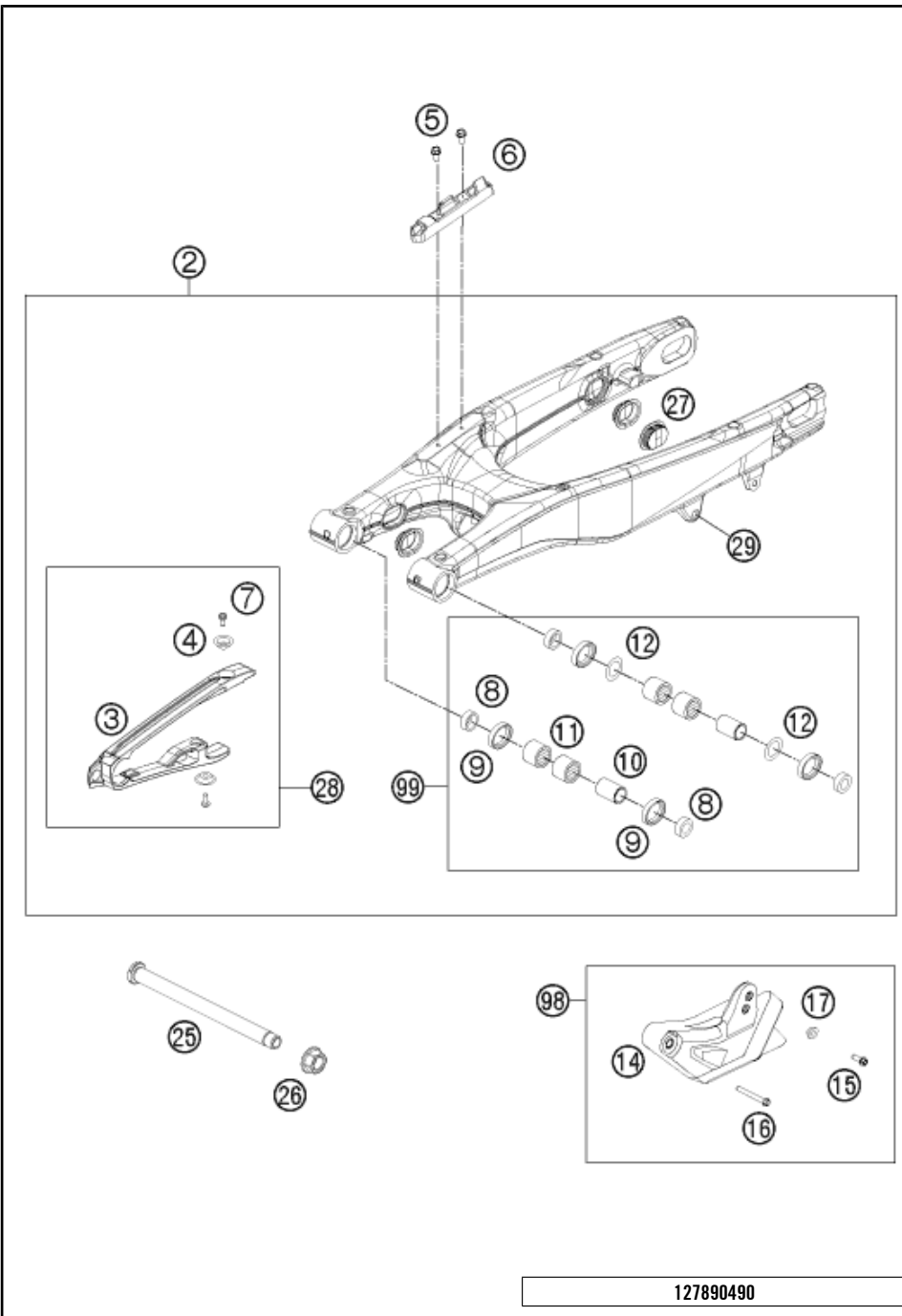

POS	PARTNUMBER	PARTNAME	PIECE
2	78904030444	SWING ARM CPL.	1
3	77204066100	CHAIN SLIDING PROTECTION	1
4	77304066050	BUSHING F. CHAIN SLIDING PR.07	2
5	0009050106	EJOT SPIRAL SCREW SF M5X10-K	2
6	76504042000	BRAKE LINE GUIDE 08	1
7	59009062013	SPECIAL SCREW M6X13 WS=8 10.9	2
8	54804034000	BUCKET F. SHAFT SEAL RING 03	4
9	0760253270	SHAFT SEAL RING 25X32X7	4
10	59404032000	BEARING SLEEVE 17X22X38,7 03	2
11	0618222812	NEEDLEBEAR HK2212V 22/28/12 MB	4
12	54603036000	STOP DISK 22,2X31,7X1	2
14	77704070000	CHAIN GUIDE REAR CPL. SX 2013	1
15	59009062019	SPECIAL SCREW M6X19 WS=8 10.9	1
16	0025060456	HH COLLAR SCREW M6X45 TX30	1
17	77304070130	BUSH. F. CHAIN FAIL. PROT. 07	1
25	77304037000	SWINGARM BOLT M16X1,5 07	1
26	54804038000	SELF LOCK.NUT M16X1,5 WS=19 03	1
27	77204041000	CLOSING COVER	4
28	77204066110	CHAIN GUARD CPL. 450 SX-F 15	1
29	54603055051	PRESS IN NUT M6 STEEL ZINC	1
98	77704070210	CHAIN GUIDE KIT REAR SX-F 14	1
99	78904230010	SWINGARM REPAIR KIT SX-F/XC-F	x

* NEW PART X ON DEMAND

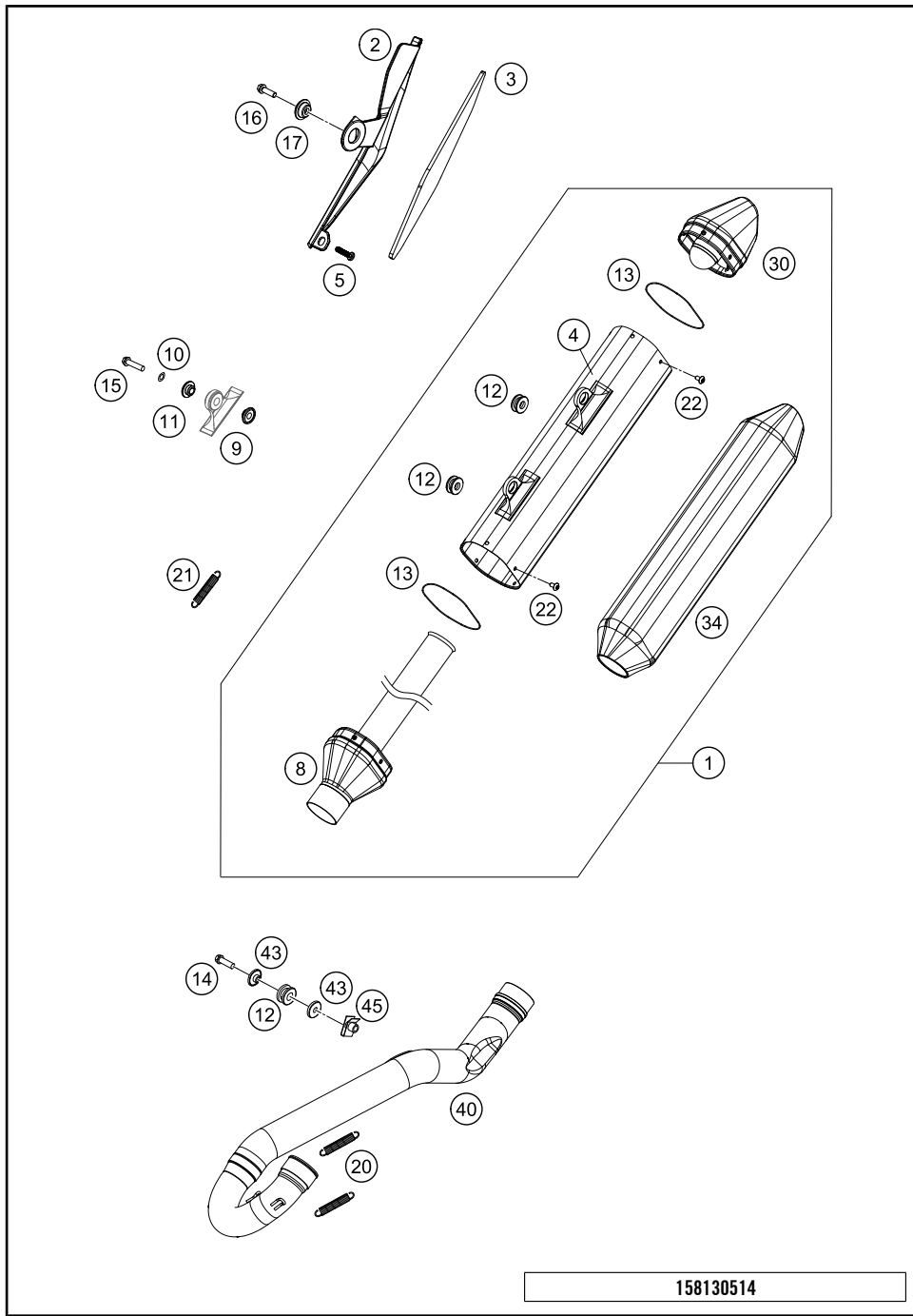

POS	PARTNUMBER	PARTNAME	PIECE
1	81305579000	SILENCER 250FC	1
2	8130501100030	HEAT SHIELD BLACK	1
3	81305011050	THERMAL PROTECTION FOIL	1
4	81305679080	SILENCER HOUSING	1
5	0081050121	SCREW FOR PLASTIC K50X12 T20	1
8	77705079050	CONNECTING CAP CPL.	1
9	81305069000	BUSHING 7,5X12X20	2
10	0137060003	SPRING WASHER DIN0137-B 6	2
11	77205169000	BUSHING 7.5x12x28x8.3 11	2
12	77205068000	DAMP. COMPON. BLACK	3
13	0770740015	O-RING 74,00X1,50 FKM 75SH	2
14	0025060256	HH COLLAR SCREW M6X25 TX30	1
15	0025060356	HH COLLAR SCREW M6X35 TX30	2
16	0025060206	HH COLLAR SCREW M6X20 TX30	1
17	77308013010	COLLAR BUSH. F.REAR FENDER 07	1
20	50305016000	TEN.SPRING L=62MM EY.MOVEABLE	2
21	50305116000	TEN.SPRING L=75MM EY.MOVEABLE	1
22	78105081010	SCREW TORX M5X10	10
30	77705079060	ENDCAP CPL.	1
34	77705078640	ROCKWOOL PREFORMED	1
40	78905007000	EXHAUST SX-F	1
43	59405069000	BUSHING FOR EXHAUST SUPPORT 03	2
45	54603048000	RANGE CHANGE METAL NUT M8	1

158130514

C158130519

* NEW PART

X ON DEMAND

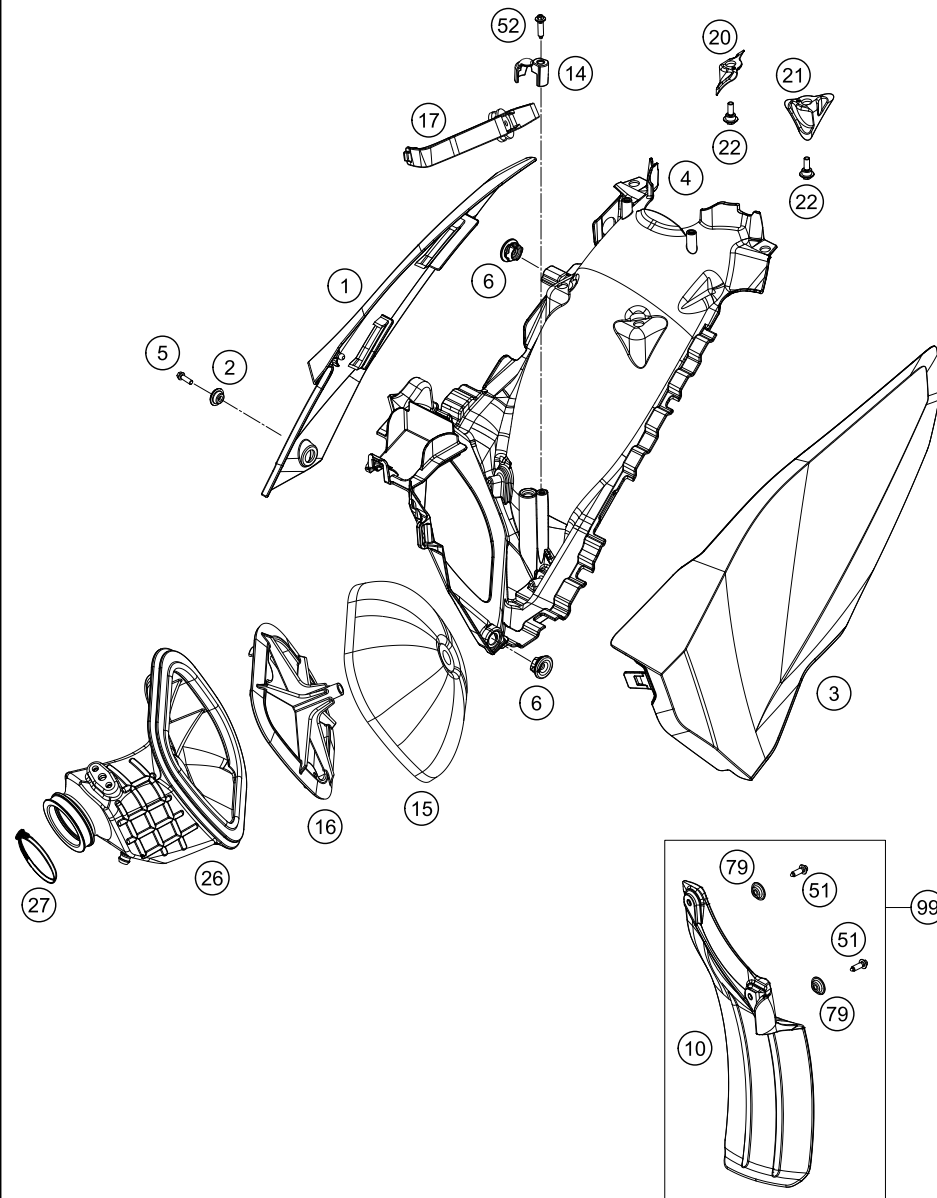

POS	PARTNUMBER	PARTNAME	PIECE
1	8130600400028E	FILTER BOX COVER R/S TE/FE 15 WITH DECAL	1
2	77308013010	COLLAR BUSH. F.REAR FENDER 07	1
3	8130600300028E	FILTER BOX COVER L/S TE/FE 15 WITH DECAL	1
4	8130610130030	AIR BOX PART	1
5	0025060206	HH COLLAR SCREW M6X20 TX30	1
6	47106003160	QUICK CONNECTOR CLUTCH	2
10	77306010000	FENDER FOR FILTER BOX	1
14	81306001010	FIXING CAP	1
15	77206015000	AIR FILTER	1
16	54806516000	FILTER CARRIER	1
17	81306017000	FILTER SUPPORT CPL.	1
20	8130600105130	COVER L/S	1
21	8130600105030	COVER R/S	1
22	83008100020	SCREW M6X20X5,5	4
26	78906026000	INTAKEBOOT	1
27	78006027000	HOSE CLAMP 45-65MM	1
51	0017060206	SCREW F. PLASTIC K60X20AL SW6	2
52	0017060255	EJOT PT SCREW K60X25-Z SW6	1
79	77304066050	BUSHING F. CHAIN SLIDING PR.07	2
99	77306010010	SPLASH PROTECTOR KIT SX/EXC	x

148130614

C158130621

* NEW PART

X ON DEMAND

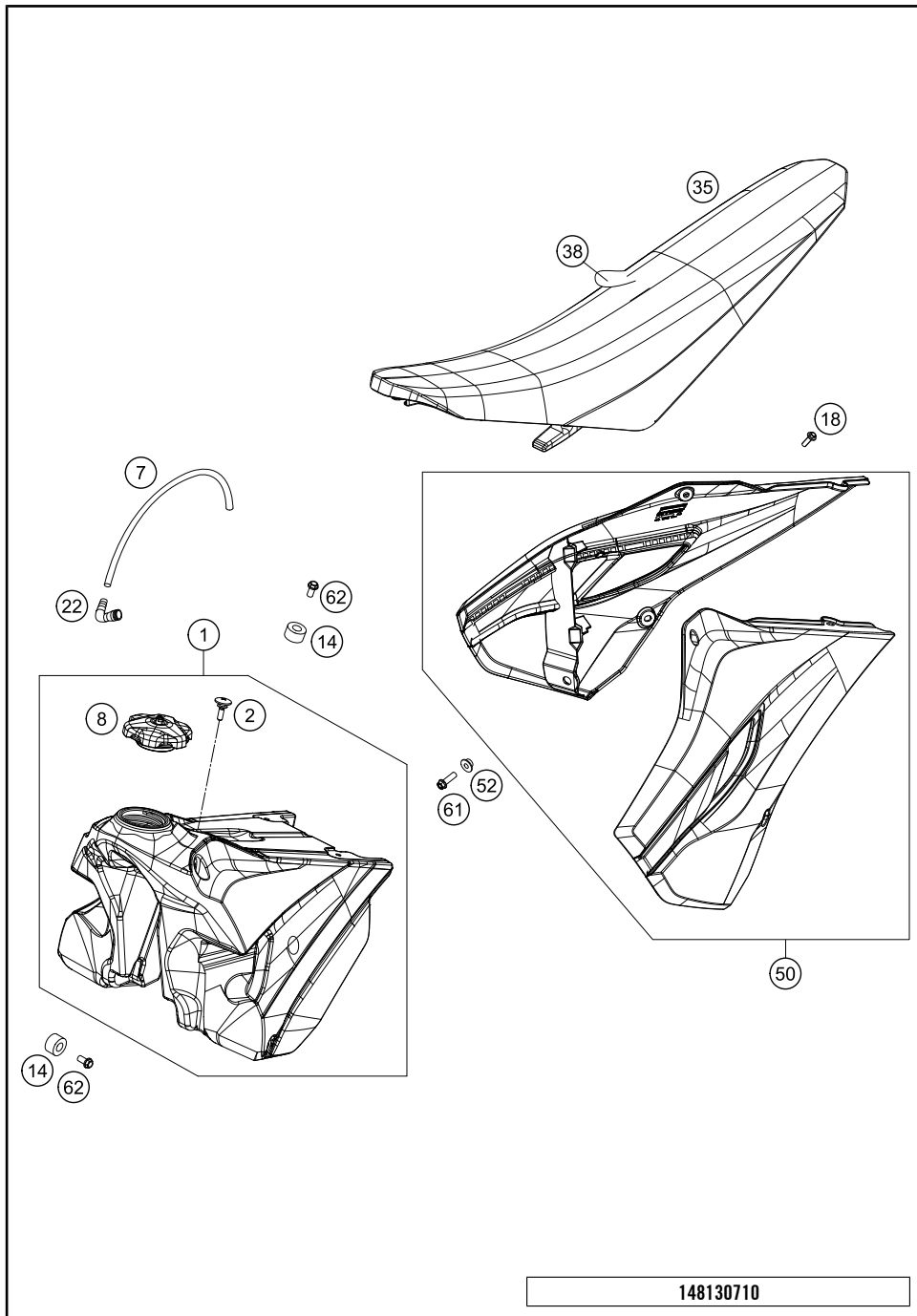

POS	PARTNUMBER	PARTNAME	PIECE
1	8130781304430	FUEL TANK CPL. 7,5L BLACK	1
2	50307011000	SCREW SEAT FASTENING D=6X23/18	1
7	78007000270	PVC-HOSE 5,6X10X270MM	1
8	7770700814455	TANK PLUG CPL. 2014	1
14	50307014000	TANK ROLLER 12X26X12 '98	3
18	0017060206	SCREW F. PLASTIC K60X20AL SW6	6
22	51030022000	ANGLE PIECE 90 DEGREE M10X1	1
35	81307840200	SEAT 2015	1
38	81307840250	SEAT COVER TC/FC 15	1
50	8130805400028D	SPOILER KIT WHITE TC/FC 2015 WITH DECAL	1
52	50308052000	BUSH FOR SPOILER 6X11X16X5 MM	2
61	0025060206	HH COLLAR SCREW M6X20 TX30	2
62	0026060136	COLLAR SCREW M6X13 ISA30	3

148130710

C158130720

* NEW PART X ON DEMAND

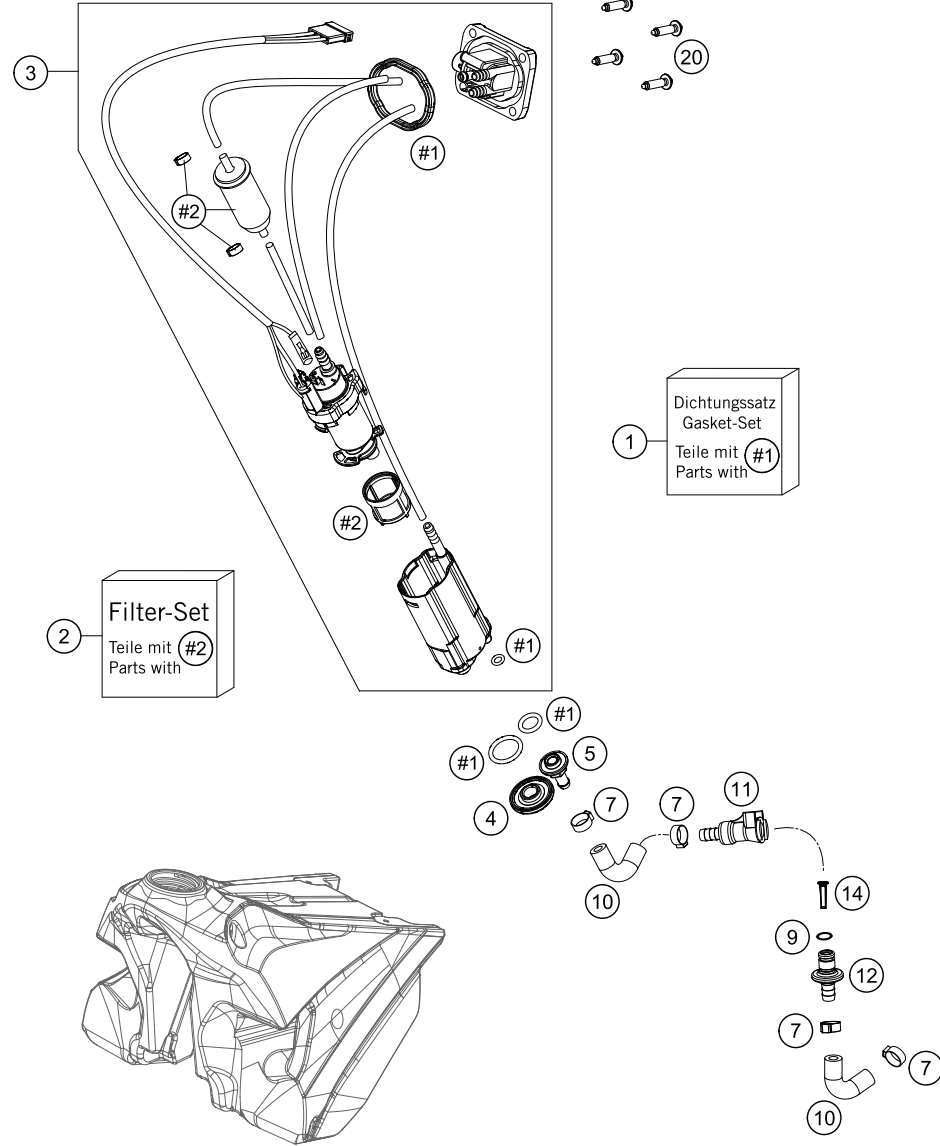

POS	PARTNUMBER	PARTNAME	PIECE
1	78107089000	GASKET KIT	1
2	81207090000	FILTER KIT	1
3	78107088000	FUEL PUMP CPL. EXC	1
4	78107088014	NUT F. FUEL PUMP M12	1
5	78107088017	FUEL CONNECTOR M8	1
7	00050157706	VARIABLE ONE-EAR CLAMP 15,7MM	4
9	58507012000	O-RING VITON F. PLUG CPC 05	1
10	77207016000	FUEL HOSE DKK	2
11	5850701050030	CLUTCH CPC BLACK 05	1
12	77707010000	CONNECTOR FUEL PUMP	1
14	78141013190	FUEL FILTER	1
20	0017060253	%EJOT PT SCREW K60X25-Z SW6	4

148130730

C158130730

* NEW PART

X ON DEMAND

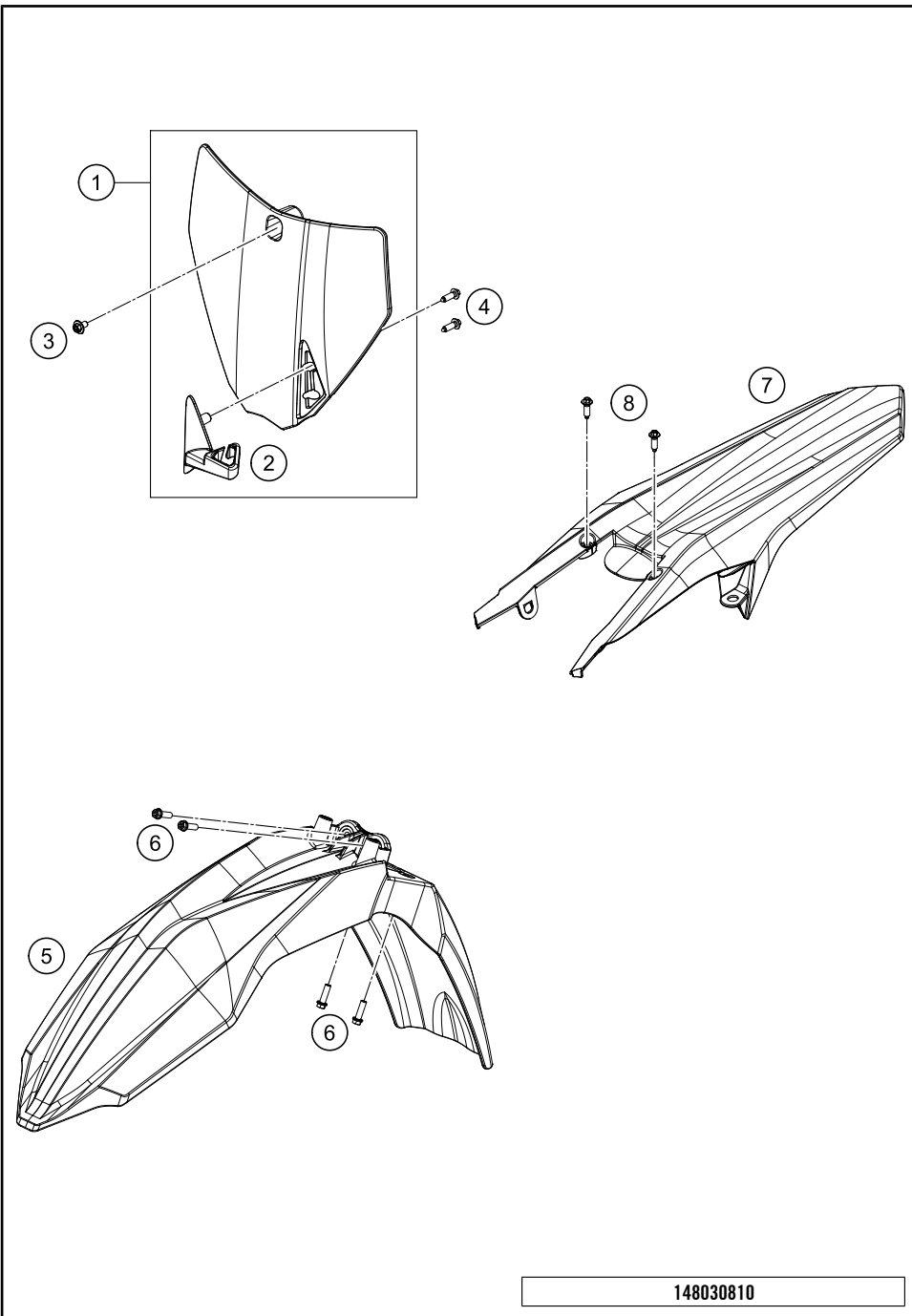

POS	PARTNUMBER	PARTNAME	PIECE
1	8130800704428	START NUMBER PLATE WHITE CPL.	1
2	8130802200030	BRAKE HOSE GUIDE 2014	1
3	0024060106	HH COLLAR SCREW M6X10 TX30	1
4	0017060206	SCREW F. PLASTIC K60X20AL SW6	2
5	8130811000028	FRONT FENDER WHITE 2014	1
6	0025060206	HH COLLAR SCREW M6X20 TX30	4
7	8130801310028	REAR FENDER	1
8	0017060205	SCREW FOR PLASTIC K60X20 SW6	2

148030810
C158130814
* NEW PART
X ON DEMAND

1

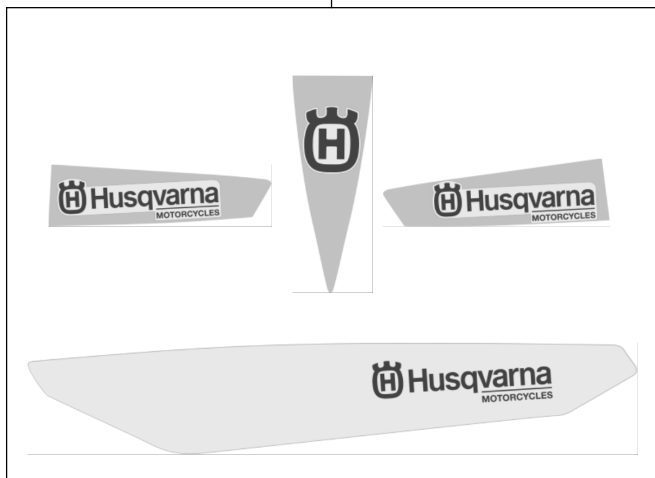

2



3



158130832

POS	PARTNUMBER	PARTNAME	PIECE
1	80308599100	DECAL KIT TE/FE/TC/FC 2015	1
2	80308698400	DISPLACEMENT STICKERS 450FC 15	1
3	52000115	STICKER FRONT FORK-SET WP"4CS"	1

C158130841

* NEW PART

X ON DEMAND

FRONT WHEEL

FC 450 US 2015

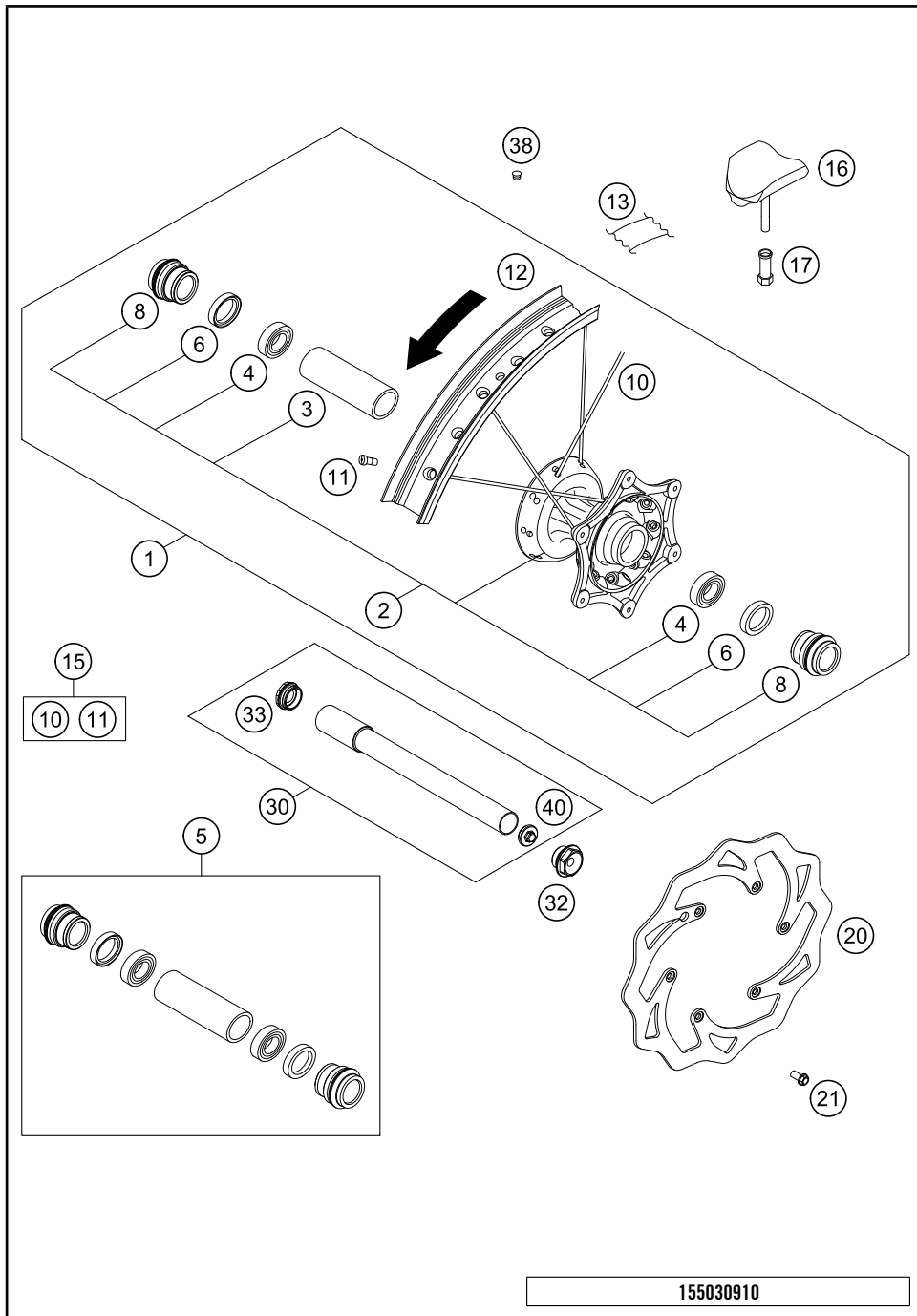

POS	PARTNUMBER	PARTNAME	PIECE
1	8030960104430	FRONT WHEEL CPL. 1,6X21" DID15	1
2	25009010044	FRONT WHEEL HUB CPL. 22MM 15	1
3	54809011000	BEA.SPACERTUBE 35X2 L=79,4 03	1
4	0625069068	GR.BALL BEAR.6906 DDU2CG23S6NM	2
5	77709015000	FRONT WHEEL REP. KIT SX-F USA	1
6	0760354771	SHAFT SEAL RING 35X47X7 TC	2
8	77709012000	SPACER BUSHING F. FR. WHEEL	2
10	77109071226	SPOKE M4,5x226-21" 11	36
11	77109072000	SPOKE NIPPLE M4,5 AL 11	36
12	8120907010030	RIM FRONT 1,60X21" DID	1
13	50309073000	RIM BAND 21"	1
15	00050000916	SPOKE KIT FRONT "21"	x
16	78109090000	RIM LOCK 1,60"	1
17	77110090050	NUT FOR WHEEL HOLDER	1
20	77309060000	BRAKE DISC FRONT 260	1
21	59009062013	SPECIAL SCREW M6X13 WS=8 10.9	6
30	77709081033	WHEEL SPIN.FR. CPL. D=22 15	1
32	70009082000	AXLESCREW M20X1.5; SW17	1
33	70009081050	PLUG BUSHING SW17 '12	1
38	55003135000	PLUG FOR RIM	x
40	7770908107055	AUXILIARY SCREW FRONT	1

155030910

C158130911

* NEW PART X ON DEMAND

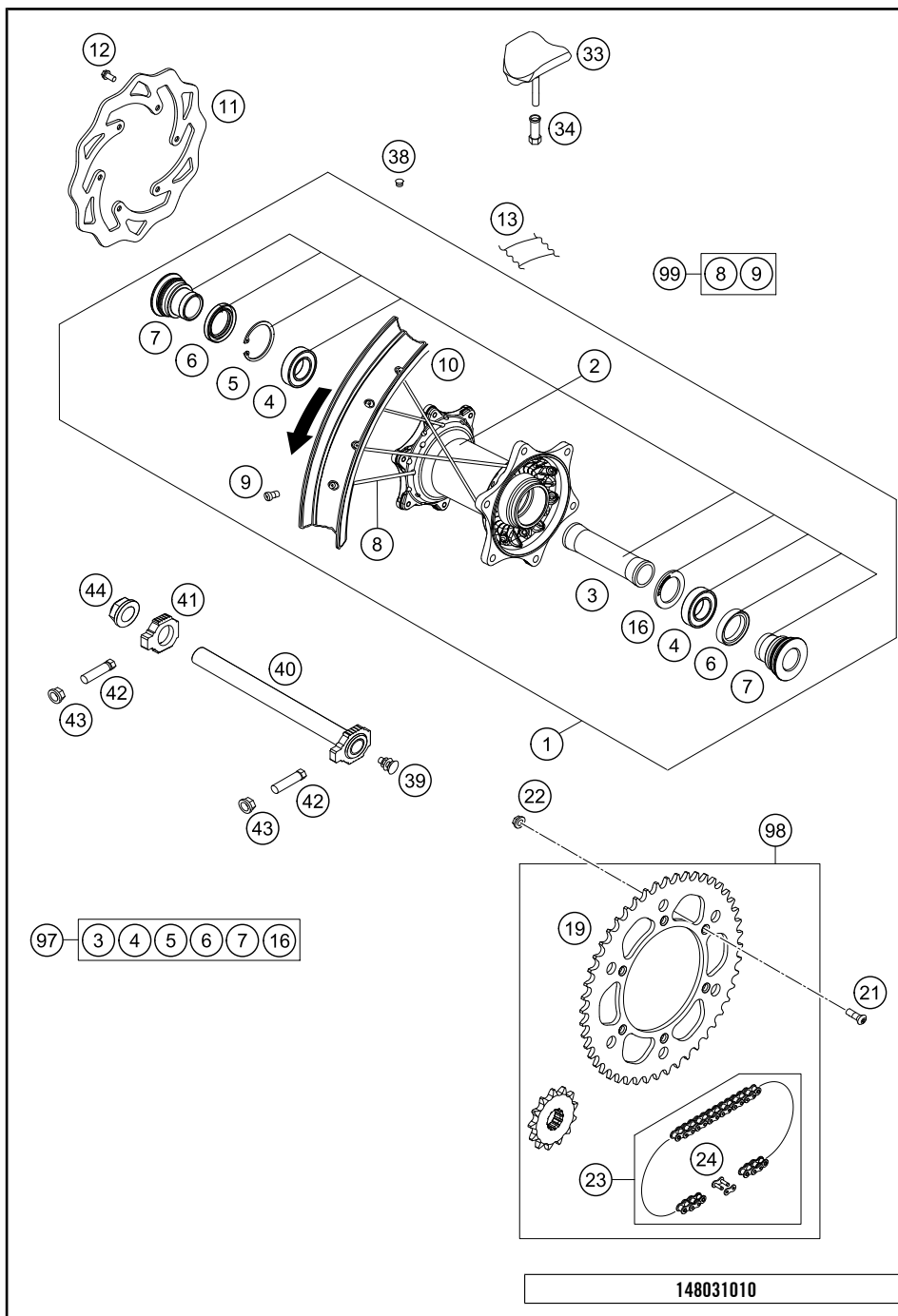

POS	PARTNUMBER	PARTNAME	PIECE
1	8031050124430	REAR WHEEL KPL.2,15X19"DID 25M	1
2	78010010244	REAR WHEEL HUB CPL. 2013	1
3	77710011000	BEARING DISTANCE TUBE 121,5MM	1
4	0625060058	GR.BALL BEAR.6005 DDU2CG23S6NM	2
5	0472047175	CIRCLIP DIN0472-47X1,75	1
6	0760324771	SHAFT SEAL RING 32X47X7 BSL	2
7	77710016000	DISTANCE BUSHING REAR WHEEL	2
8	77110071205	SPOKE M4,5x205-19" 11	36
9	77109072000	SPOKE NIPPLE M4,5 AL 11	36
10	8121017010030	RIM 2,15X19 DID BLACK	1
11	77310060000	BRAKE DISC REAR 220	1
12	59009062013	SPECIAL SCREW M6X13 WS=8 10.9	6
13	50310073200	RIM BAND 18" AND 19"	1
16	77710015000	DISTANCE RING	1
19	7771015104830	SPROCKET 48-T BLACK	x
19	7771015105030	SPROCKET 50-T BLACK	1
19	7771015105230	SPROCKET 52-T BLACK	x
21	0019080266S	COUNTER-SUNK SCREW ISA45 M8X26	6
22	06923080003	HEXAGON NUT DIN EN1661 M8 SW13	6
23	50310165118	CHAIN 5/8X1/4" MX	1
24	50310166000	CONNECTING LINK F. 50310165118	1
33	78110090000	RIM LOCK 2,15"	1
34	77110090050	NUT FOR WHEEL HOLDER	1
38	55003135000	PLUG FOR RIM	x
39	50210086000	COVERING CAP SFL16	x
40	77710085044	WHEEL SPINDLE CPL. '13	1
41	77710084000	CHAIN TENSIONER R/S	1
42	50304040100	SCREW M10X1,25X50 WS=10	2
43	58414030000	HH COLLAR NUT M10X1,25 WS=13	2
44	61010086000	COLLAR NUT M25X1,5 WS=32 05	1
97	77710015010	REAR WHEEL REP. KIT	x
98	00050002044	DRIVETRAIN KIT HQV 13T/50T	x
99	00050000917	SPOKE KIT REAR "19"	x

148031010

C158131015

* NEW PART X ON DEMAND

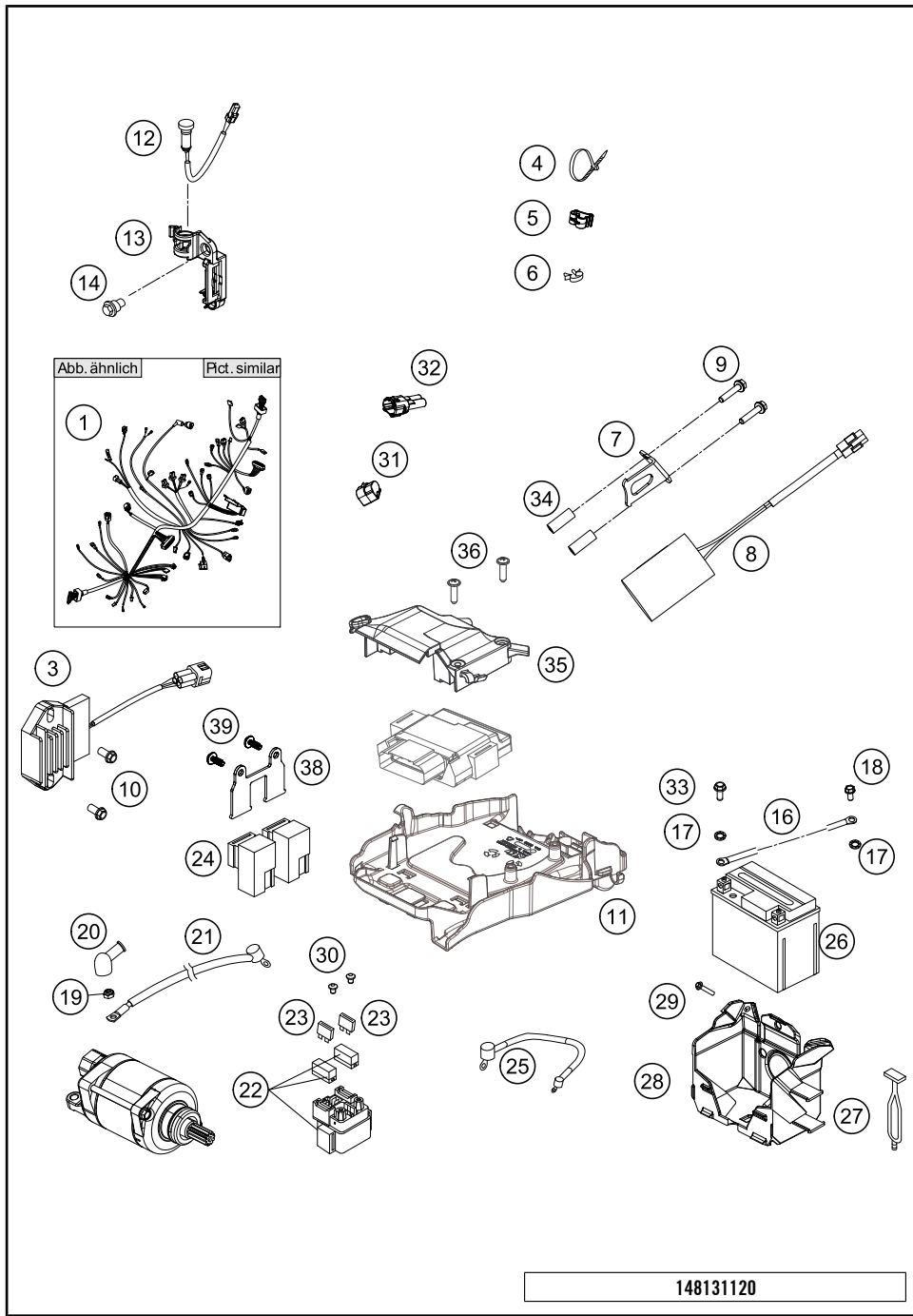

POS	PARTNUMBER	PARTNAME	PIECE
1	77711075200	WIRING HARNESS SX-F 2014	1
3	77211034000	VOLTAGE REGULATOR 09	1
4	44011076140	CABLE TIE 140/2,5MM BLACK	x
4	44011076200	CABLE TIE 200/3,6MM BLACK	x
4	44011076305	CABLE TIE 300/4,8MM BLACK	x
5	83013026000	CABLE GUIDE	2
6	57013072100	WIRING HOLDER 16MM	x
7	77711036000	RETAINING PLATE CONDENSATOR	1
8	77711035000	CONDENSATOR	1
9	0025050306	HH COLLAR SCREW M5X30 TX30	2
10	0025060206	HH COLLAR SCREW M6X20 TX30	2
11	77711094000	ELECTRIC BOX	1
12	81214083000	INDICATOR LIGHT LED YELLOW FI	1
13	77214098000	HOLDER INDICATOR LIGHT SX	1
14	59001092050	SPECIAL SCREW M6X12,5 WS=8	1
16	58411097100	GROUND CABLE D=6MM L=140MM '97	1
17	58411098100	CONTACT WASHER M6 VSV-K6	3
18	0009050106	EJOT SPIRAL SCREW SF M5X10-K	1
19	0985060003	SELF LOCK. NUT DIN0985-M 6	1
20	77240099000	PROTECTION CAP F. STARTER ENG.	1
21	81311059000	STARTER CABLE	1
22	76211058000	STARTER RELAY 07	1
23	58011109110	FUSE 10 A 2000	2
24	61111057000	RELAY CM1A-R-12V-H80 07	1
25	81311059050	WIRING HARNESS BATTERY	1
26	77311053000	BATTERY 12V 3AH YTX4L-BS	1
27	50303018000	RUBBER L=145MM	1
28	77211055000	BATTERY BOX	1
29	0017060205	SCREW FOR PLASTIC K60X20 SW6	3
30	0902060083	AH OVAL SCREW ISO 7380 M 6X8	2
31	77211010050	DUMMY PLUG MAPSELECTSWITCH	1
32	69011040000	END PLUG CAN-BUS 08	1
33	0025050126	HH COLLAR SCREW M5X12 TX30	2
34	77711036050	BUSHING CONDENSATOR BRACKET	2
35	77711094050	ECU SPLASH PROTECT.	1
36	0081645121	EJOT DELTA PT SCREW 45X12-Z	2
38	81311037000	BRACKET POWERRELAIS	1
39	0081050121	SCREW FOR PLASTIC K50X12 T20	2

148131120

C148131123

* NEW PART X ON DEMAND

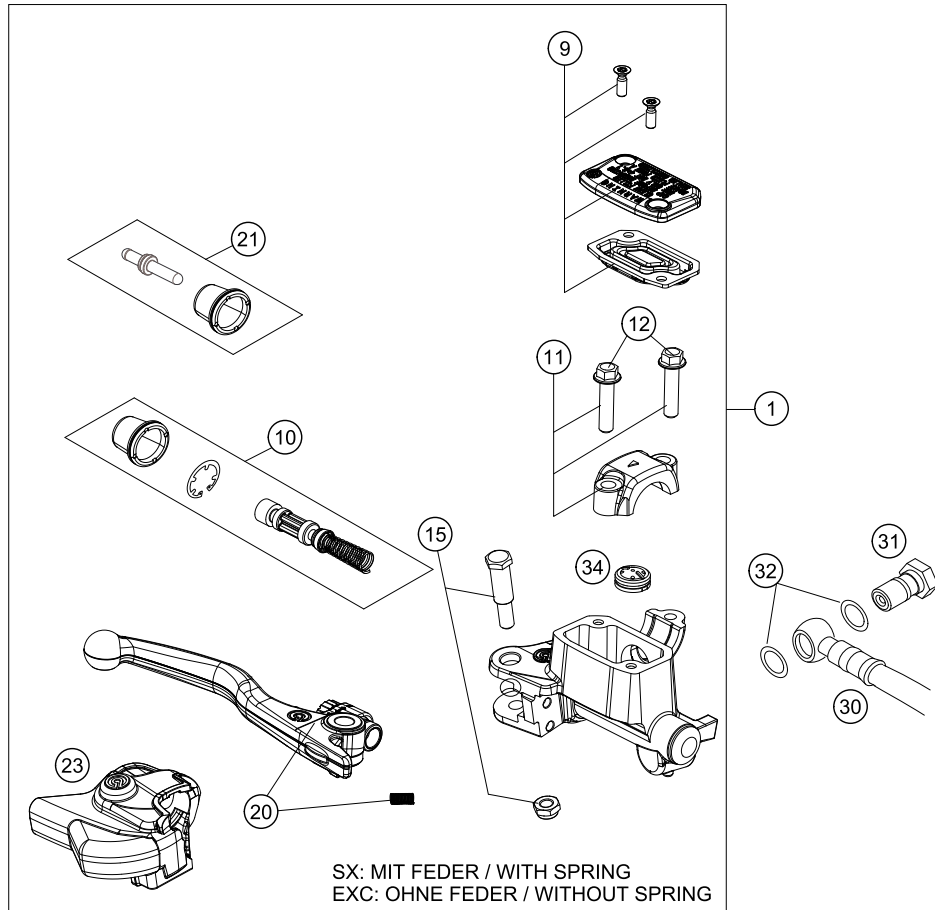

POS	PARTNUMBER	PARTNAME	PIECE
1	77713001044	HAND BREAK CYLIND. CPL. X 2014	1
9	77713003000	HAND BRAKE CYL. COVER	1
10	77713008000	REPAIR KIT PISTON SX 2014	1
11	54802005100	CLAMP CPL. 06	1
12	0025060256	HH COLLAR SCREW M6X25 TX30	2
15	77713006000	LEVER SCREW	1
20	77713002000	HAND BRAKE LEVER +SPRING SX 14 SX WITH SPRING, EXC W/O SPR.	1
21	77713007000	PUSH ROD CPL. SX 2014	1
23	77713004000	PROTECTION CAP HAND BRAKE CYL.	1
30	59013010000	BRAKEHO. FRONT 1235MM 2000	1
31	54813020100	HOLLOW SCREW BLACK M10X1X19	1
32	0603100141	COPPER GASKET DIN7603-10X14X1	2
34	54802051000	VALVE	1
80	00062030000	BRAKE FLUID DOT5.1 0,25L	1

147781310

C148031310

* NEW PART

X ON DEMAND

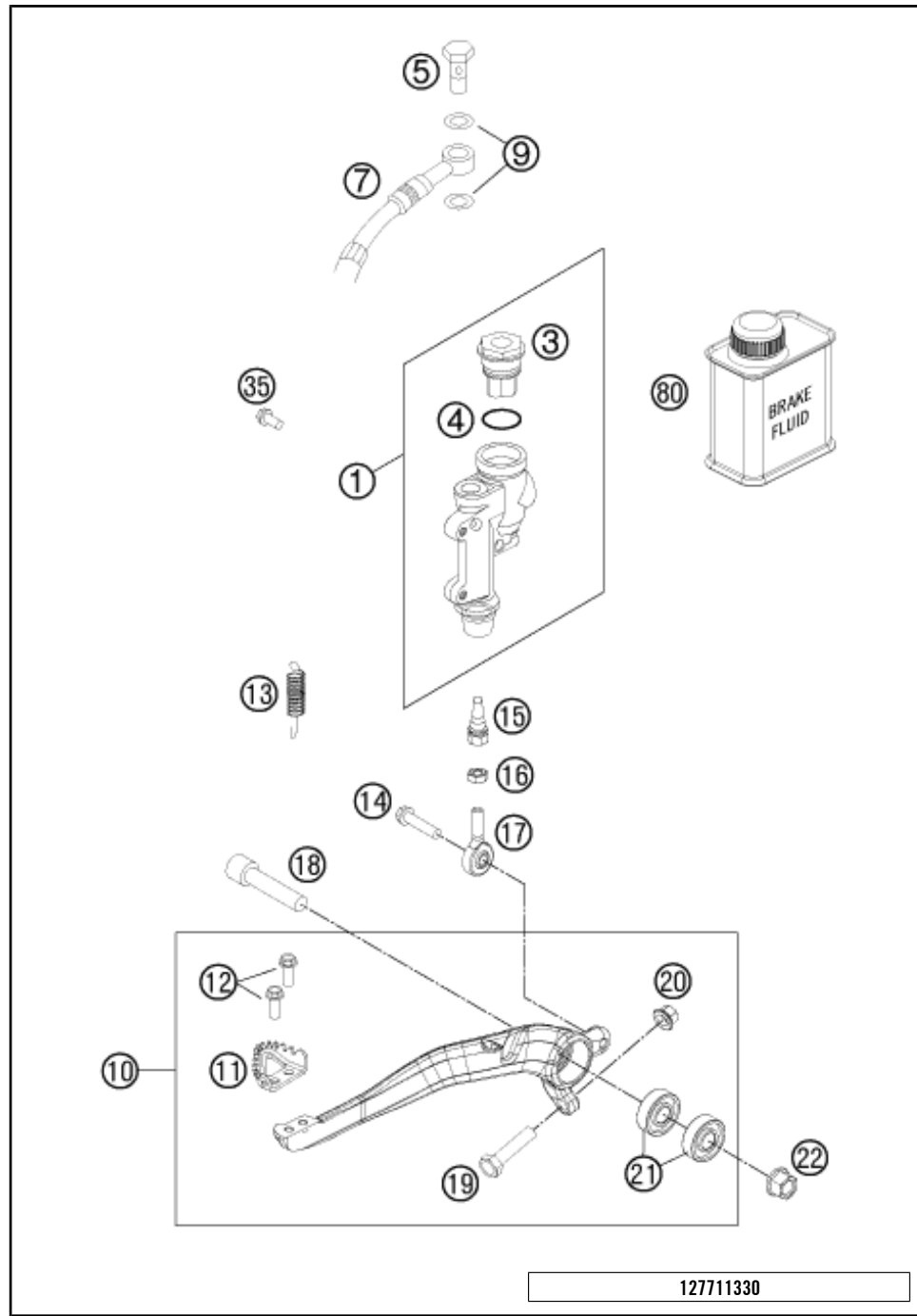

POS	PARTNUMBER	PARTNAME	PIECE
1	77013060044	REAR BRAKE CYLINDER CPL.SX 09	1
3	54813062100	REAR BRAKE CYL. COVER CPL. 04	1
4	54813063000	FOOT-BRAKE CYL. GASKET SX 03	1
5	54813020100	HOLLOW SCREW BLACK M10X1X19	1
7	77213070000	% BRAKE HOSE REAR XXXMM 11	1
9	0603100141	COPPER GASKET DIN7603-10X14X1	2
10	77213050044	FOOT BRAKE LEVER CPL.	1
11	54813051000	STEP PLATE FOR BRAKE LEVER	1
12	0025050126	HH COLLAR SCREW M5X12 TX30	2
13	54603062000	% RETURN SPRING FOR BRAKELEVER	1
14	0025060206S	HH COLLAR SCREW M6X20 TX30	1
15	54813056000	PUSH ROD L=28MM 03	1
16	0985060003	SELF LOCK. NUT DIN0985-M 6	1
17	54813055000	SWIVEL HEAD KA6 03	1
18	0032100406S	AH-COLLAR SCREW M10X40 ISA45	1
19	59001037000	SPECIAL SCREW M8X26 WS=10	1
20	46030045000	COLLAR NUT M8 WS=10	1
21	0625060002	BALL BEARING SKF 6000-2RS1	2
22	54630044000	COLLAR NUT M10 WS=13	1
35	0025060126	HH COLLAR SCREW M6X12 TX30	2
80	00062030000	BRAKE FLUID DOT5.1 0,25L	1

127711330

C157771330

* NEW PART X ON DEMAND

BRAKE CALIPER FRONT

FC 450 US 2015

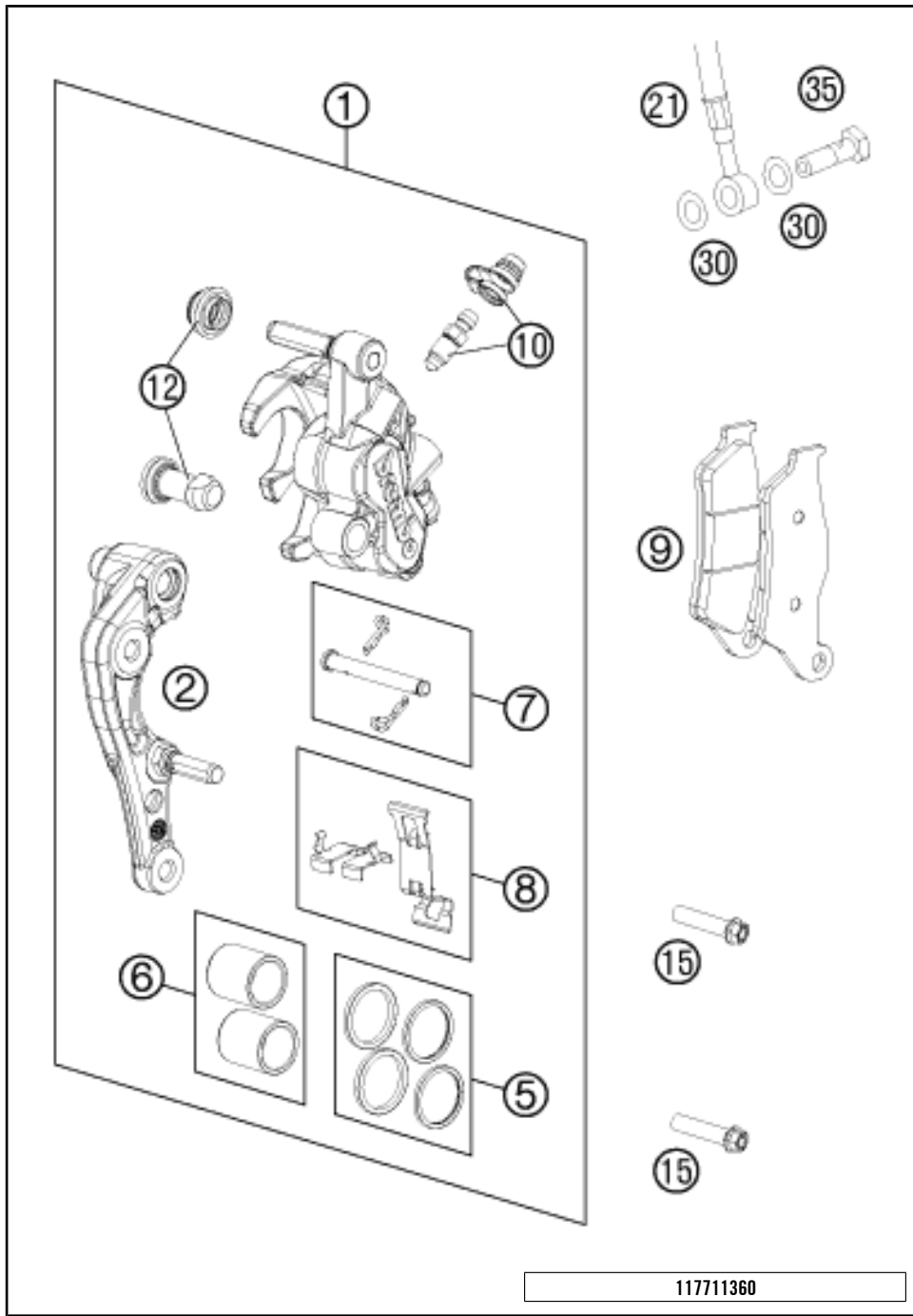

POS	PARTNUMBER	PARTNAME	PIECE
1	7701301500101	CALIPER NAT. WITHOUT PADS	1
2	77013014000	BRAKE CALIPER SUPPORT FRONT 09	1
5	77013021000	REP. KIT SEALS 24MM	1
6	77013019000	REP. KIT PISTON 24MM	1
7	77013017000	BOLT CPL. 09	1
8	77013018000	RETAINING PLATE SET BREMBO	1
9	77713030000	BRAKE PADS FRONT	1
10	61013020100	BLEEDER SCREW WITH CAP	1
12	54613218000	CUP SET SHORT	1
15	0025080306S	HH COLLAR SCREW M8X30 TX40	2
21	59013010000	BRAKEHO. FRONT 1235MM 2000	1
30	0603100141	COPPER GASKET DIN7603-10X14X1	2
35	50213025000	HOLLOW SCREW M10X1X19	1

117711360

C158131361

* NEW PART X ON DEMAND

BRAKE CALIPER REAR

FC 450 US 2015

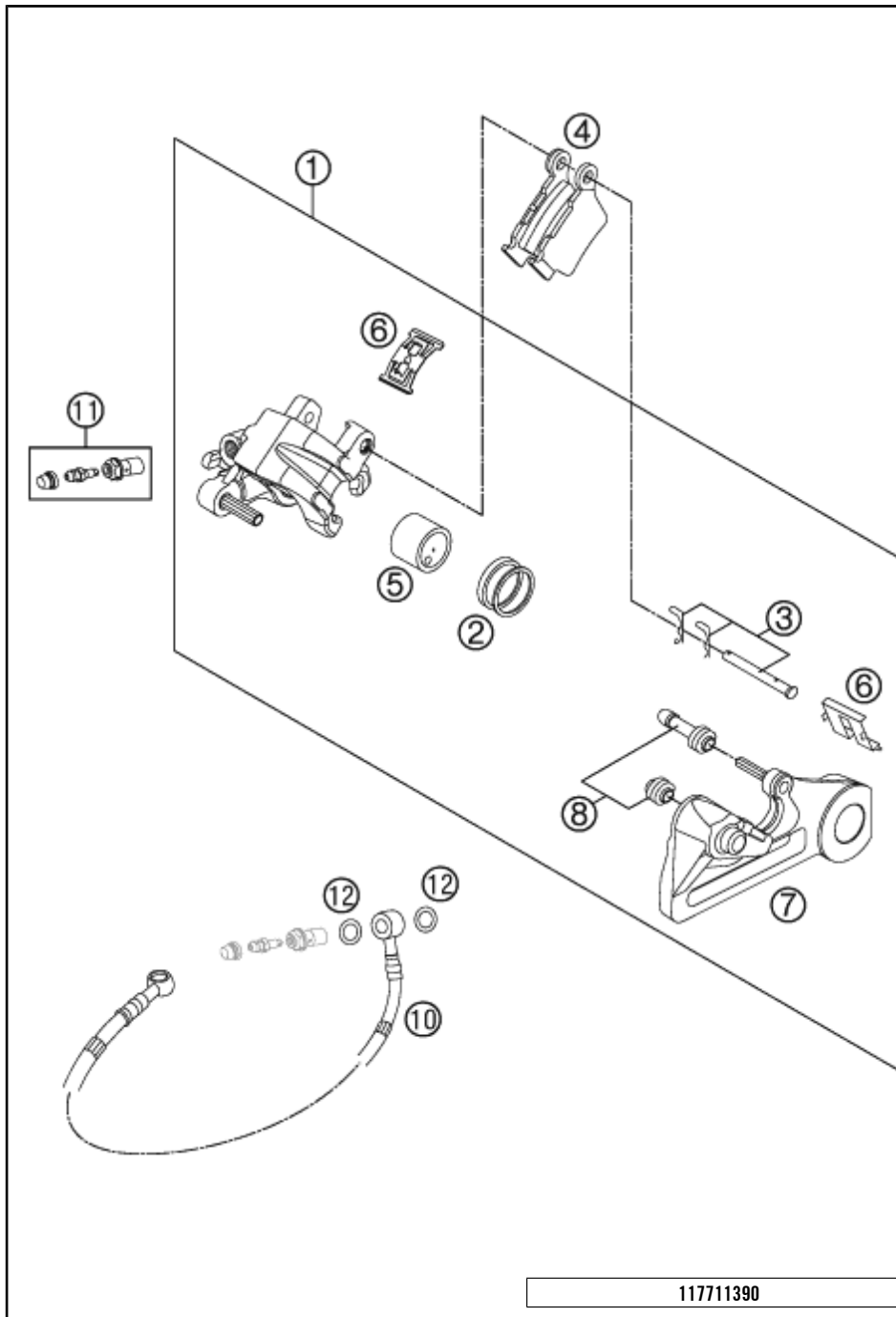

POS	PARTNUMBER	PARTNAME	PIECE
1	77713080001	BRAKE CAL. REAR - WITHOUT PADS	1
2	50313081200	REPAIR KIT SEALING RINGS 26MM	1
3	54813082000	BOLT SET FOR BRAKE CALIPER 03	1
4	54813090300	BRAKE PAD SET REAR TOYO	1
5	77713083000	BRAKE PISTON 26MM 2013	1
6	54813018000	RETAINING SPRING SET 2003	1
7	77713075000	BRAKE CALIPER BRACKET REAR	1
8	54613218000	CUP SET SHORT	1
10	77213070100	BRAKE HOSE REAR	1
11	62513020000	BLEEDER SCREW CPL. 05	1
12	0603100141	COPPER GASKET DIN7603-10X14X1	2

117711390

C157771390

* NEW PART

X ON DEMAND

0
OHNE ABBILDUNG
WITHOUT ILLUSTRATION

1
TECHNISCHE DOKUMENTATION
TECHNICAL DOCUMENTATION
DOCUMENTACION TECNICA
DOCUMENTATION TECHNIQUE
NOTE TECNICHE

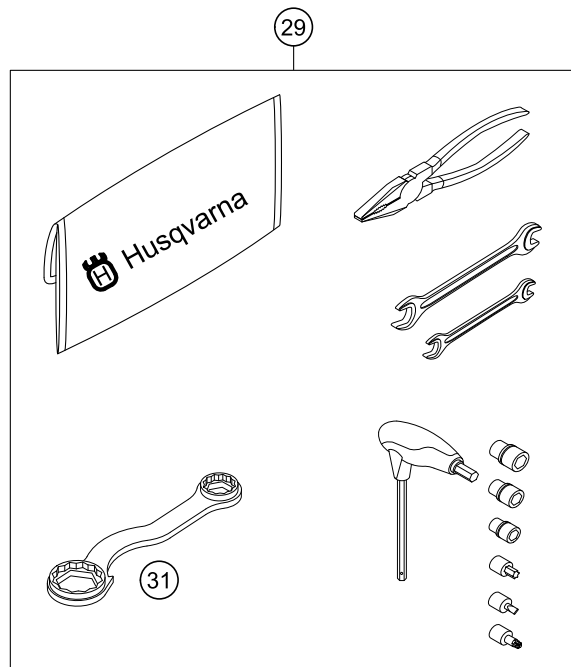

POS	PARTNUMBER	PARTNAME	PIECE
0	HQV0110	HUSQVARNA BALLPOINT PEN	1
0	80312002000	DOCUMENTS BAG HUSQVARNA	1
0	HQV0109	HUSQVARNA NOTE-PAD	1
0	00063004202	PRINT LABEL 60X51 MM	1
0	78003040033	FOOTREST L/S + R/S CPL. 09	1
0	80302602144	BAR PAD 2015	1
0	0025050126	HH COLLAR SCREW M5X12 TX30	2
0	58411098100	CONTACT WASHER M6 VSV-K6	2
0	7770217900028	HAND GUARDS CPL. L/S+R/S WHITE	1
0	77703020000	PLUG-IN STAND	1
0	8130811003328A	FRONT FENDER W. DECAL 2015	1
0	0025060206	HH COLLAR SCREW M6X20 TX30	4
0	77311053000	BATTERY 12V 3AH YTX4L-BS	1
0	81212016100	WASH CAP SET	1
0	78029072000	SPARK PLUG SOCKET	1
0	78141013190	FUEL FILTER	3
0	HQV0010GB/ES	HUSKY STYLE FOLDER 2015	1
0	52000115	STICKER FRONT FORK-SET WP"4CS"	1
1	3402021EN	OWNERS MANUAL 450 FC 15	1
29	80329899000	TOOL KIT	1
31	50329080100	WRENCH SW=17/21/27/32 B&F	1

148132000

C158132019

* NEW PART

X ON DEMAND



- ⑤ Ø 5 mm
- ⑥ Ø 6 mm
- ⑧ Ø 8 mm
- ⑩ Ø 10 mm
- ⑫ Ø 12 mm
- ⑭ Ø 14-14,5 mm
- ⑯ Ø 16 mm
- ⑳ Ø 20 mm
- ㉑ Ø 21 mm
- ㉒ Ø 22 mm
- ㉓ Ø 23 mm
- ㉔ Ø 24,5 mm
- ㉘ Ø 28,5 mm
- ㉚ Ø 32 mm
- ㉜ Ø 52 mm

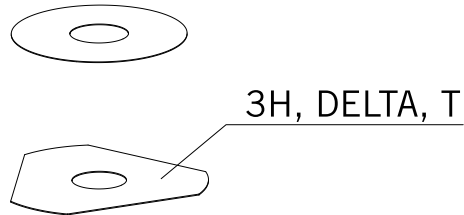

POS	PARTNUMBER	PARTNAME	PIECE
5	44906890	WASHER 5X15X2	X
6	40540400	SHIM 6X12X0,1	X
6	40540401	SHIM 6X14X0,1	X
6	40540402	SHIM 6X16X0,1	X
6	40540403	SHIM 6X18X0,1	X
6	40540404	SHIM 6X12X0,15	X
6	40540405	SHIM 6X14X0,15	X
6	40540406	SHIM 6X16X0,15	X
6	40540407	SHIM 6X18X0,15	X
6	40540408	SHIM 6X12X0,2	X
6	40540409	SHIM 6X14X0,2	X
6	40540410	SHIM 6X16X0,2	X
6	40540411	SHIM 6X18X0,2	X
6	48600095	* SHIM 6X20X0,20	X
6	40540412	SHIM 6X12X0,25	X
6	40540413	SHIM 6X14X0,25	X
6	40540414	SHIM 6X16X0,25	X
6	40540415	SHIM 6X18X0,25	X
6	40540417	SHIM 6X8,5X0,10	X
6	40540418	SHIM 6X9X0,10	X
6	40540419	SHIM 6X9,5X0,10	X
6	40540423	SHIM 6X9,5X0,15	X
6	40540425	SHIM 6X8,5X0,20	X
6	40540426	SHIM 6X9X0,20	X
6	40540427	SHIM 6X9,5X0,20	X
6	40540447	SHIM 6X10X0,3	X
6	40540449	SHIM 6X9X0,3	X
6	40540450	SHIM 6X9,5X0,3	X
6	40540494	SHIM 6X18X0,4	X
6	40540774	SHIM 6X18X0,1 DELTA	X
6	40541383	SHIM 6X11X0,1	X
6	40541391	SHIM 6X11X0,3	X
6	40541402	SHIM 6X11X0,2	X
6	40541403	SHIM 6X10X0,20	X
6	40541404	SHIM 6X10X0,1	X
6	40541405	SHIM 6X10X0,15	X
6	40541406	SHIM 6X11X0,15	X
6	40541408	SHIM 6X8,0X0,30	X

080000190

C130009090

* NEW PART

X ON DEMAND



- ⑤ Ø 5 mm
- ⑥ Ø 6 mm
- ⑧ Ø 8 mm
- ⑩ Ø 10 mm
- ⑫ Ø 12 mm
- ⑭ Ø 14-14,5 mm
- ⑯ Ø 16 mm
- ⑳ Ø 20 mm
- ㉑ Ø 21 mm
- ㉒ Ø 22 mm
- ㉓ Ø 23 mm
- ㉔ Ø 24,5 mm
- ㉘ Ø 28,5 mm
- ㉚ Ø 32 mm
- ㉜ Ø 52 mm



POS	PARTNUMBER	PARTNAME	PIECE
6	40541414	SHIM 6X8,0X0,10	X
6	40541416	SHIM 6X8X0,3	X
6	40541417	SHIM 6X11X0,25	X
6	48600102	* SHIM 6X24X0,25	X
6	48600063	SHIM 6X24X0,1	X
6	48600064	SHIM 6X22X0,1	X
6	48600065	SHIM 6X20X0,1	X
6	48600069	SHIM 6X20X0,15	X
6	48600100	SHIM 6X24X0,15	X
6	48600116	SHIM 6X24X0,1 DELTA	X
6	48600139	SHIM 6X22X0,1 DELTA	X
6	48600217	BACKPLATE 6X10X0,25	X
6	48600325	SHIM 6X13X0,1	X
6	48600327	SHIM 6X15X0,1	X
6	48600329	SHIM 6X17X0,1	X
6	48600331	SHIM 6X19X0,1	X
6	48600096	* SHIM 6X20X0,25	X
6	48600097	SHIM 6X22X0,15	X
6	48600099	* SHIM 6X22X0,25	X
6	40540448	BACKPLATE 6X8,5X0,30	X
6	48600479	SHIM 6X20X0,1 T/3H	X
6	48600332	SHIM 6X21X0,1	X
6	48600333	SHIM 6X23X0,1	X
6	40541393	* SHIM 6X12X0,3	X
6	48600330	SHIM 6X17X0,15	X
6	48600988	SHIM 6X28X0,10	X
6	48600989	SHIM 6X26X0,10	X
6	48601091	SHIM 6X28X0,15	X
6	48601093	SHIM 6X26X0,15	X
8	40540477	SHIM 8X18X0,4	X
8	43570120	SHIM 8X18X0,10	X
8	44916098	WASHER 8,4X16X0,8	X
8	44916130	WASHER 8,2X15X1	X
8	44916180	WASHER 8,2X11X1	X
8	48600214	SHIM 8X16X0,1	X
8	48600385	SHIM 8x14x0.25	X
8	48600346	SHIM 8X11X0,2	X
8	48600215	CHECK VALVE 8X20X0,1	X

080000190

C130009090

* NEW PART

X ON DEMAND



- ⑤ Ø 5 mm
- ⑥ Ø 6 mm
- ⑧ Ø 8 mm
- ⑩ Ø 10 mm
- ⑫ Ø 12 mm
- ⑭ Ø 14-14,5 mm
- ⑯ Ø 16 mm
- ⑳ Ø 20 mm
- ㉑ Ø 21 mm
- ㉒ Ø 22 mm
- ㉓ Ø 23 mm
- ㉔ Ø 24,5 mm
- ㉘ Ø 28,5 mm
- ㉚ Ø 32 mm
- ㉞ Ø 52 mm



POS	PARTNUMBER	PARTNAME	PIECE
8	48600485	SHIM 8X10X0,10	X
8	48601402	SHIM 8X13X0,10	X
8	48600061	CHECK VALVE 8X24X0,4	X
8	48600062	CHECK VALVE 8X24X0,1	X
8	48600216	CHECK VALVE 8X22X0,1	X
8	48600480	SHIM 8X10X0,20	X
8	48600555	SHIM 8X16X0,20	X
8	48600213	SHIM 8X14X0,10	X
8	48600357	CHECK VALVE 8X11X0,1	X
8	48600351	CHECK VALVE 8X12X0,1	X
8	48600607	SHUTTLE VALVE 8X20X0,4	X
8	48601095	SHIM 8X17X0,10	X
8	48600352	CHECK VALVE 8X11X0,4	X
10	36120284	SHIM 10X16X0,10	X
10	36120298	SHIM 10X16X0,2	X
10	36120312	SHIM 10X16X0,30	X
10	36120314	SHIM 10X18X0,30	X
10	36120325	SHIM 10X19X0,15	X
10	36120327	SHIM 10X23X0,15	X
10	36120328	SHIM 10X25X0,15	X
10	36120329	SHIM 10X27X0,15	X
10	36120330	SHIM 10X29X0,15	X
10	36120331	SHIM 10X31X0,15	X
10	36120332	SHIM 10X33X0,15	X
10	36120334	SHIM 10X21X0,20	X
10	36120335	SHIM 10X23X0,20	X
10	36120336	SHIM 10X25X0,20	X
10	36120337	SHIM 10X27X0,20	X
10	36120338	SHIM 10X29X0,20	X
10	36120339	SHIM 10X31X0,20	X
10	36120340	SHIM 10X33X0,20	X
10	36120342	SHIM 10X21X0,25	X
10	36120343	SHIM 10X23X0,25	X
10	36120344	SHIM 10X25X0,25	X
10	36120345	SHIM 10X27X0,25	X
10	36120349	SHIM 10X19X0,30	X
10	36120350	SHIM 10X21X0,30	X
10	40140275	WASHER 10X35X0,15	X

080000190

C130009090

* NEW PART

X ON DEMAND



- ⑤ Ø 5 mm
- ⑥ Ø 6 mm
- ⑧ Ø 8 mm
- ⑩ Ø 10 mm
- ⑫ Ø 12 mm
- ⑭ Ø 14-14,5 mm
- ⑯ Ø 16 mm
- ⑳ Ø 20 mm
- ㉑ Ø 21 mm
- ㉒ Ø 22 mm
- ㉓ Ø 23 mm
- ㉔ Ø 24,5 mm
- ㉘ Ø 28,5 mm
- ㉚ Ø 32 mm
- ㉜ Ø 52 mm



POS	PARTNUMBER	PARTNAME	PIECE
10	36120346	* SHIM 10X29X0,25	X
10	50180010	* SHIM 16X24X0,10	X
10	36120604	SHIM D10XD22X2,5	X
12	46810490	SHIM 12X24X0,20	X
12	46810491	SHIM 12X26X0,20	X
12	46810492	SHIM 12X28X0,20	X
12	46810493	SHIM 12X30X0,20	X
12	46810494	SHIM 12X32X0,20	X
12	46810495	SHIM 12X34X0,20	X
12	46810496	SHIM 12X36X0,20	X
12	46810497	SHIM 12X38X0,20	X
12	46810498	SHIM 12X40X0,20	X
12	46810499	SHIM 12X24X0,25	X
12	46810500	SHIM 12X26X0,25	X
12	46810501	SHIM 12X28X0,25	X
12	46810502	SHIM 12X30X0,25	X
12	46810504	SHIM 12X34X0,25	X
12	46810505	SHIM 12X36X0,25	X
12	46810507	SHIM 12X40X0,25	X
12	46810508	SHIM 12X24X0,30	X
12	46810509	SHIM 12X26X0,30	X
12	46810510	SHIM 12X28X0,30	X
12	46810512	SHIM 12X32X0,30	X
12	46810513	SHIM 12X34X0,30	X
12	46810518	SHIM 12X26X0,15	X
12	46810519	SHIM 12X28X0,15	X
12	46810520	SHIM 12X30X0,15	X
12	46810521	SHIM 12X32X0,15	X
12	46810522	SHIM 12X34X0,15	X
12	46810523	SHIM 12X36X0,15	X
12	46810524	SHIM 12X38X0,15	X
12	46810525	SHIM 12X40X0,15	X
12	46810604	SHIM 12X20X0,10	X
12	46810606	SHIM 12X22X0,10	X
12	46810607	SHIM 12X23X0,10	X
12	46810608	SHIM 12X24X0,10	X
12	46810610	SHIM 12X27X0,15	X
12	46810611	SHIM 12X18X0,15	X

080000190

C130009090

* NEW PART

X ON DEMAND



- ⑤ Ø 5 mm
- ⑥ Ø 6 mm
- ⑧ Ø 8 mm
- ⑩ Ø 10 mm
- ⑫ Ø 12 mm
- ⑭ Ø 14-14,5 mm
- ⑯ Ø 16 mm
- ⑳ Ø 20 mm
- ㉑ Ø 21 mm
- ㉒ Ø 22 mm
- ㉓ Ø 23 mm
- ㉔ Ø 24,5 mm
- ㉘ Ø 28,5 mm
- ㉚ Ø 32 mm
- ㉜ Ø 52 mm



POS	PARTNUMBER	PARTNAME	PIECE
12	46810612	SHIM 12X19X0,15	X
12	46810615	SHIM 12X22X0,15	X
12	46810636	BACKPLATE 12X16X0,30	X
12	46810637	BACKPLATE 12X17X0,30	X
12	46810638	BACKPLATE 12X18X0,30	X
12	46810639	SHIM 12X19X0,30	X
12	46810641	BACKPLATE 12X21X0,30	X
12	46811582	BACKPLATE 12X30X0,10	X
12	46810631	SHIM 12X20X0,25	X
12	46810633	SHIM 12X22X0,25	X
12	46811580	SHIM 12X32X0,10	X
12	46810503	SHIM 12X32X0,25	X
12	46810517	* SHIM 12X24X0,15	X
12	46810640	SHIM 12X20X0,30	X
12	46811258	RING 12X24X2,5	X
12	46812018	SHIM 12X42X0,25	X
12	46812015	SHIM 12X44X0,20	X
14	46811046	SHIM 14,5X35,4X1,25	X
16	50180023	* SHIM 16X23X0,20	X
16	50180030	SHIM	X
16	50180006	BACKPLATE 16X20X0,10	X
16	50180007	SHIM 16X21X0,10	X
16	50180028	SHIM 16X21X0,25	X
16	50180210	WASHER 16X21X1	X
16	50180008	SHIM 16X22X0,10	X
16	50180022	SHIM 16X22X0,20	X
16	50180037	SHIM 16X23X0,30	X
16	50180038	SHIM 16X24X0,30	X
16	50180032	SHIM 15X25X0,25	X
16	50180039	SHIM 16X25X0,30	X
16	50180012	SHIM 16X26X0,10	X
16	50180019	SHIM 16X26X0,15	X
16	50180026	SHIM 16X26X0,20	X
16	50180040	SHIM 16X26X0,30	X
16	50180041	SHIM 16X28X0,10	X
16	50180045	SHIM 16X28X0,15	X
16	50180054	SHIM 16X28X0,20	X
16	50180063	SHIM 16X28X0,25	X

080000190

C130009090

* NEW PART

X ON DEMAND



- ⑤ Ø 5 mm
- ⑥ Ø 6 mm
- ⑧ Ø 8 mm
- ⑩ Ø 10 mm
- ⑫ Ø 12 mm
- ⑭ Ø 14-14,5 mm
- ⑯ Ø 16 mm
- ⑳ Ø 20 mm
- ㉑ Ø 21 mm
- ㉒ Ø 22 mm
- ㉓ Ø 23 mm
- ㉔ Ø 24,5 mm
- ㉘ Ø 28,5 mm
- ㉚ Ø 32 mm
- ㉜ Ø 52 mm



POS	PARTNUMBER	PARTNAME	PIECE
16	50180072	SHIM 16X28X0,30	X
16	50180046	SHIM 16X30X0,15	X
16	50180055	SHIM 16X30X0,20	X
16	50180064	SHIM 16X30X0,25	X
16	50180073	SHIM 16X30X0,30	X
16	50180047	SHIM 16X32X0,15	X
16	50180056	SHIM 16X32X0,20	X
16	50180065	SHIM 16X32X0,25	X
16	50180074	SHIM 16X32X0,30	X
16	50180044	SHIM 16X34X0,10	X
16	50180048	SHIM 16X34X0,15	X
16	50180057	SHIM 16X34X0,20	X
16	50180066	SHIM 16X34X0,25	X
16	50180075	SHIM 16X34X0,30	X
16	50180049	SHIM 16X36X0,15	X
16	50180058	SHIM 16X36X0,20	X
16	50180067	SHIM 16X36X0,25	X
16	50180076	SHIM 16X36X0,30	X
16	50180050	SHIM 16X38X0,15	X
16	50180059	SHIM 16X38X0,20	X
16	50180068	SHIM 16X38X0,25	X
16	50180077	SHIM 16X38X0,30	X
16	50180051	SHIM 16X40X0,15	X
16	50180060	SHIM 16X40X0,20	X
16	50180069	SHIM 16X40X0,25	X
16	50180078	SHIM 16X40X0,30	X
16	50180052	SHIM 16X42X0,15	X
16	50180061	SHIM 16X42X0,20	X
16	50180070	SHIM 16X42X0,25	X
16	50180079	SHIM 16X42X0,30	X
16	50180053	SHIM 16X44X0,15	X
16	50180062	SHIM 16X44X0,20	X
16	50180071	SHIM 16X44X0,25	X
16	50180080	SHIM 16X44X0,30	X
16	50180177	WASHER 16X8,2X0,6	X
16	50180033	SHIM 16X26X0,25	X
16	50180034	BACKPLATE 16X20X0,30	X
16	50180035	BACKPLATE 16X21X0,30	X

080000190

C130009090

* NEW PART

X ON DEMAND



- ⑤ Ø 5 mm
- ⑥ Ø 6 mm
- ⑧ Ø 8 mm
- ⑩ Ø 10 mm
- ⑫ Ø 12 mm
- ⑭ Ø 14-14,5 mm
- ⑯ Ø 16 mm
- ⑳ Ø 20 mm
- ㉑ Ø 21 mm
- ㉒ Ø 22 mm
- ㉓ Ø 23 mm
- ㉔ Ø 24,5 mm
- ㉘ Ø 28,5 mm
- ㉚ Ø 32 mm
- ㉜ Ø 52 mm



POS	PARTNUMBER	PARTNAME	PIECE
16	50180036	BACKPLATE 16X22X0,30	X
16	50180043	SHIM	X
16	50180024	* SHIM 16X24X0,20	X
16	50180027	* SHIM 16X20X0,25	X
16	50180031	SHIM	X
16	50180029	SHIM	X
20	48600212	PRESSURE-RING 20X16,25X0,20	X
20	50180666	SHIM 20X24X0,30	X
20	50180654	SHIM 20X36X0,20	X
20	50180655	SHIM 20X38X0,20	X
20	50180656	SHIM 20X40X0,20	X
20	50180665	SHIM 20X40X0,25	X
20	50180662	SHIM 20X34X0,25	X
20	50180657	SHIM 20X24X0,25	X
20	50180653	SHIM 20X34X0,20	X
20	50180634	RING 20X22,9X1	X
20	50180650	SHIM 20,2X28X0,20	X
20	50180663	SHIM 20X36X0,25	X
20	50180664	SHIM 20X38X0,25	X
20	50180659	SHIM 20,2X28X0,25	X
21	50180209	WASHER 21X36X0,25	X
22	50180330	* PRESS. RING 22X18X0,30	X
23	50180635	SHUTTLE VALVE 23X38X0,25	X
23	50180578	SHIM D23XD16X2	X
24	40541061	WASHER 24,5X34X2	X
28	36120469	SHIM 28,5X14X2	X
28	36120471	SHIM 28,5X14X5	X
32	48600460	WASHER 32X42X2,5	X
32	50600065	SHIM 32X45X2	X
32	46811637	PRESSURE RING 36X32,25	X
52	50600002	SHIM 52X59X2,2	X

080000190

C130009090

* NEW PART

X ON DEMAND

A large, empty rectangular box with a thin black border, occupying the majority of the page. It is intended for handwritten notes.

A large, empty rectangular box with a thin black border, occupying the majority of the page. It is intended for the user to write their notes.

A large, empty rectangular box with a thin black border, occupying the majority of the page. It is intended for handwritten notes.



3CFF247501EN



Husqvarna Motorcycles GmbH
Stallhofnerstraße 3 | 5230 Mattighofen | Austria
www.husqvarna-motorcycles.com



THE PIONEERS OF MOTOCROSS

SPAREPARTSCATALOG

ENGINE

ART.-NR.: 3CM0895770EN

FC 450 2015

ENGINE CASE

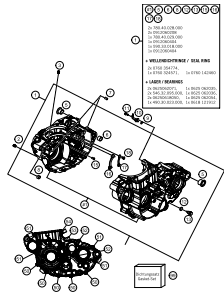

3

CLUTCH COVER

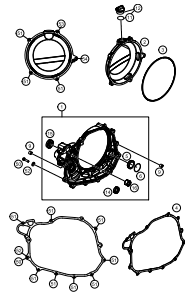

4

BALANCER SHAFT

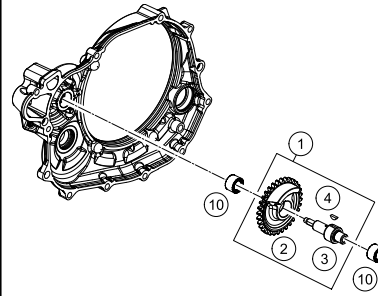

5

CYLINDER

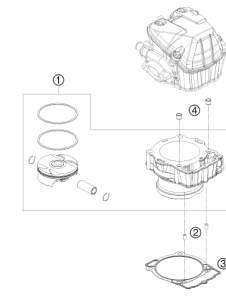

6

CRANKSHAFT, PISTON

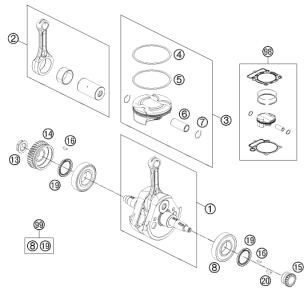

7

CLUTCH

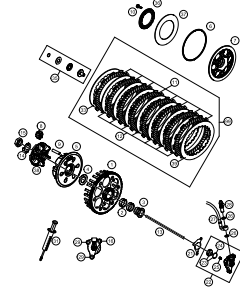

8

TRANSMISSION I - MAIN SHAFT

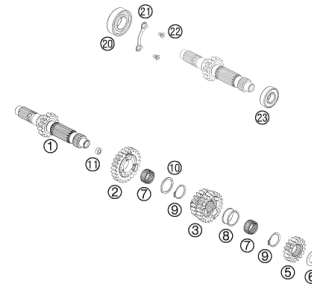

9

TRANSMISSION II - COUNTERSHAFT

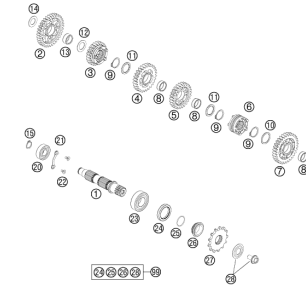

10

SHIFTING MECHANISM

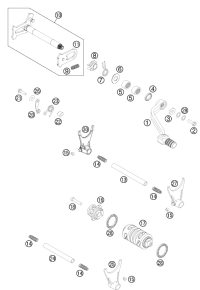

11

WATER PUMP

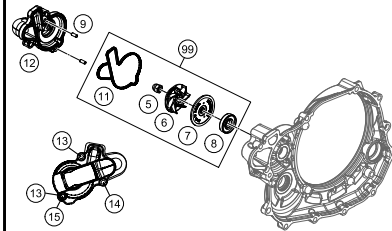

12

COOLING SYSTEM

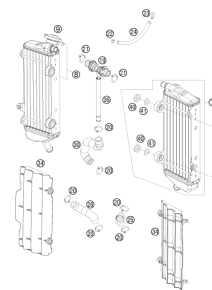

13

VALVE DRIVE

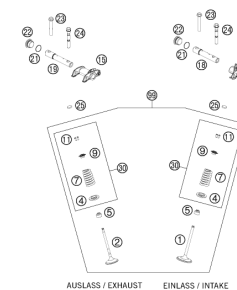

AUSLASS / EXHAUST EINLASS / INTAKE

14

TIMING DRIVE

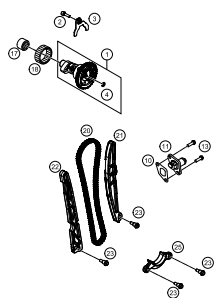

16

CYLINDER HEAD

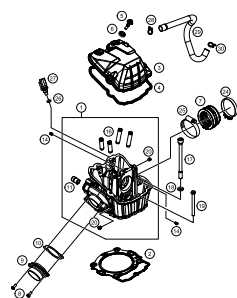

17

LUBRICATING SYSTEM

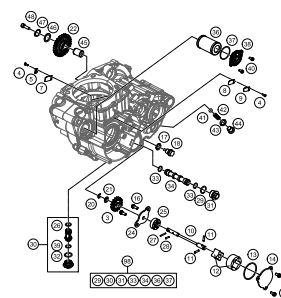

18

IGNITION SYSTEM

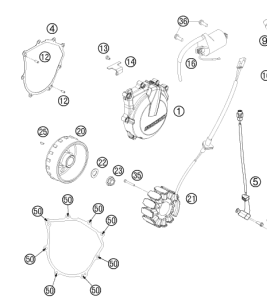

20

ELECTRIC STARTER

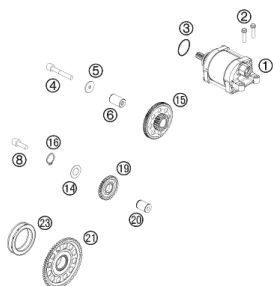

21

THROTTLE BODY

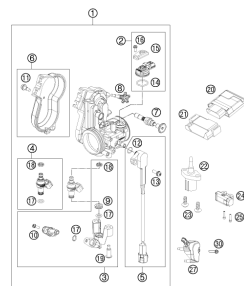

22



All information contained is without obligation. HUSQVARNA MOTORCYCLES GmbH particularly reserves the right to modify any equipment, technical specifications, prices, colors, shapes, materials, services, service work, constructions, equipment and the like so as to adapt them to local conditions or to cancel any of the above items, all without previous announcement and without giving reasons. KTM may stop manufacturing certain models without previous notice. HUSQVARNA MOTORCYCLES shall not be held liable for any deviations of availability and/or ability to deliver, illustrations, descriptions, printing and/or other errors. The illustrated models partly contain extra equipment, which is not applied to standard models.

© by HUSQVARNA MOTORCYCLES GmbH, Mattighofen AUSTRIA; All rights reserved; Reprint, also in extracts, with written allowance of HUSQVARNA MOTORCYCLES GmbH, Mattighofen only.

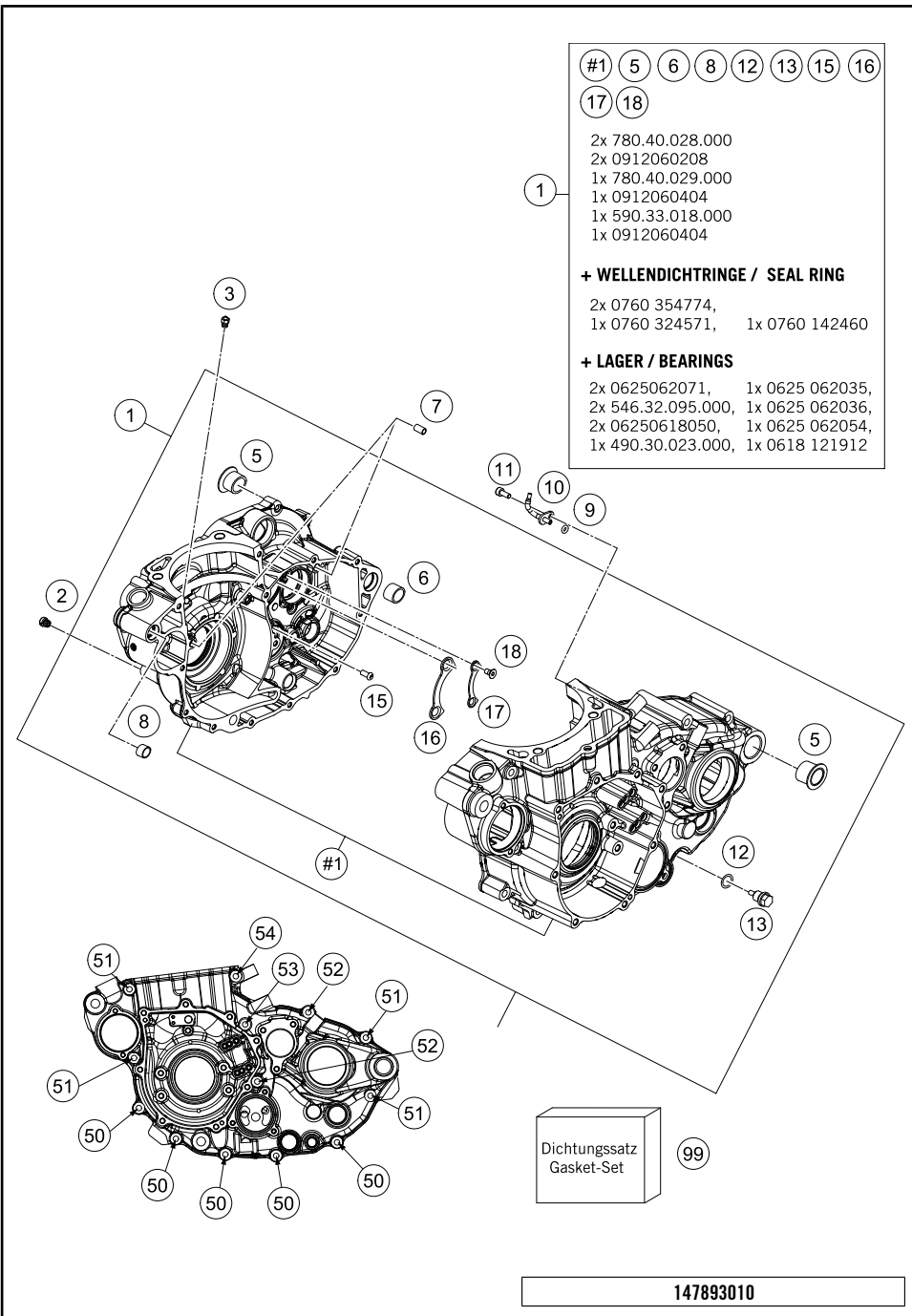

POS	PARTNUMBER	PARTNAME	PIECE
1	78130100033	ENGINE CASE CPL.	1
2	57031523145	MAIN JET 145	1
3	60030063070	OIL JET 70 M5	1
5	75030010100	CASE BUSH	2
6	54830027000	DOWEL 21X12 03	1
7	59030023000	DOWEL 6X8X11,5	2
8	51030026100	DOWEL 17 X 13 X 12	1
9	0770035020	O-RING 3,5X2,00 NBR	1
10	81230064000	OIL JET ANGLED 70	1
11	0912040103	AH.SCREW DIN0912-M 4X10	1
12	58038022000	CU-SEAL RING DIN7603-12X18X1,5	1
13	58030021000	OILDRAIN PLUG W.MAG. M 12X1,5	1
15	0018050103	INT. TORX OVAL HEAD M 5X10 8.8	1
16	78033032000	TAB WASHER BEARING MAIN SHAFT	1
17	78033132000	TAB WASHER BEARING COUNT.SHAFT	1
18	0019050121S	INT. TORX FLAT HEAD M5X12 T25	4
50	0025060406	HH COLLAR SCREW M6X40 TX30	5
51	0025060606	HH COLLAR SCREW M6X60 TX30	4
52	0025060756	HH COLLAR SCREW M6X75 TX30	2
53	0025060806	HH COLLAR SCREW M6X80 TX30	1
54	0025060856	HH COLLAR SCREW M6X85 TX30	1
99	78130099000	GASKET SET 450/500 EXC 12	1

C147893010

* NEW PART X ON DEMAND

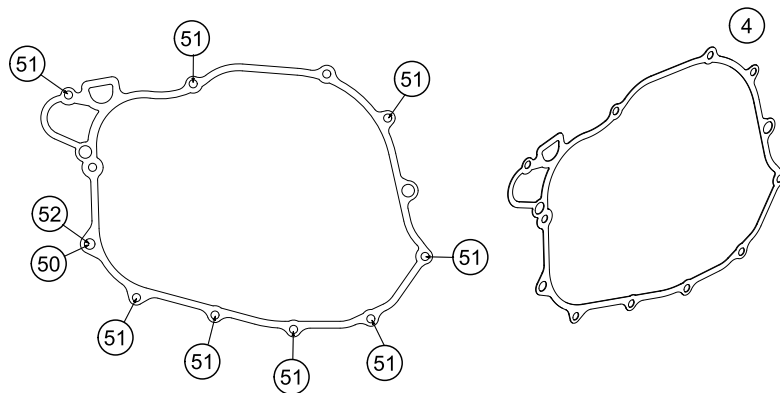
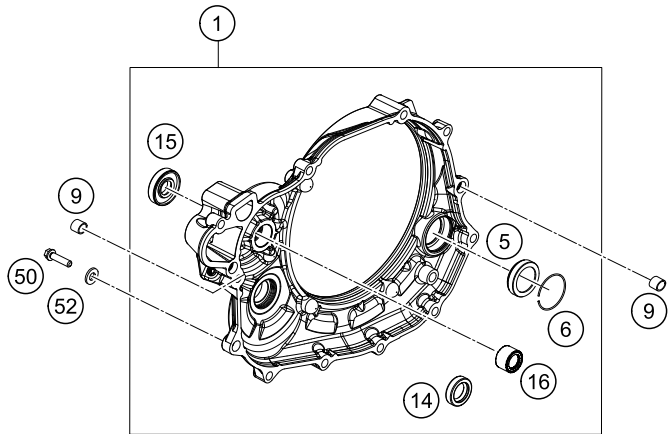
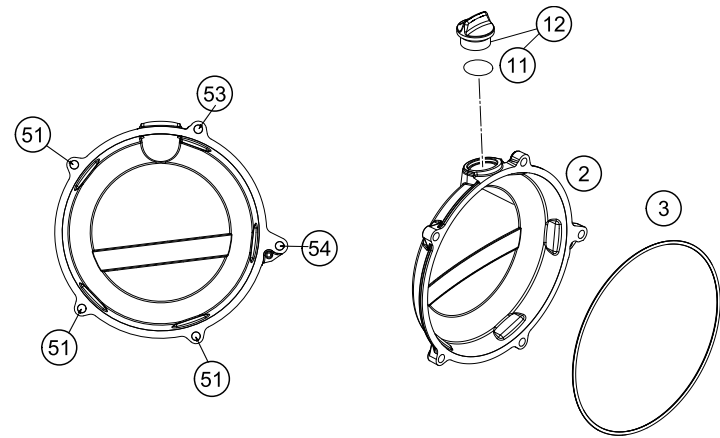

POS	PARTNUMBER	PARTNAME	PIECE
1	78130101044	CLUTCH COVER CPL.	1
2	78130626000KA	OUTER CLUTCH COVER "HQV"	1
3	78130027000	GASKET - CLUTCH OUTER COVER	1
4	78130125000	CLUTCH COVER GASKET	1
5	78030095100	OIL LEVEL GLASS VITON	1
6	61030019050	CIRCLIP OIL LEVEL GLASS O3	1
9	49030090000	DOWEL 9,8 X 7 X 10	2
11	0770191015	O-RING 19,00X3,00 NBR	1
12	58030120000	OIL FILLER CAP M24x3 WITH O-R	1
14	0760142460	SHAFT SEAL RING 14X24X6 B	1
15	0760123073	SHAFT SEAL RING 12X30X7 PTFE	1
16	0618121912	NEEDLE BUSH NK1212	1
50	78030080000	LOCATING SCREW	1
51	0025060256	HH COLLAR SCREW M6X25 TX30	11
52	58030081000	CU-SEAL RING 8 X 14 X 3	1
53	0025060556	HH COLLAR SCREW M6X55 TX30	1
54	0025060606	HH COLLAR SCREW M6X60 TX30	1

137893021

C147893020

* NEW PART

X ON DEMAND

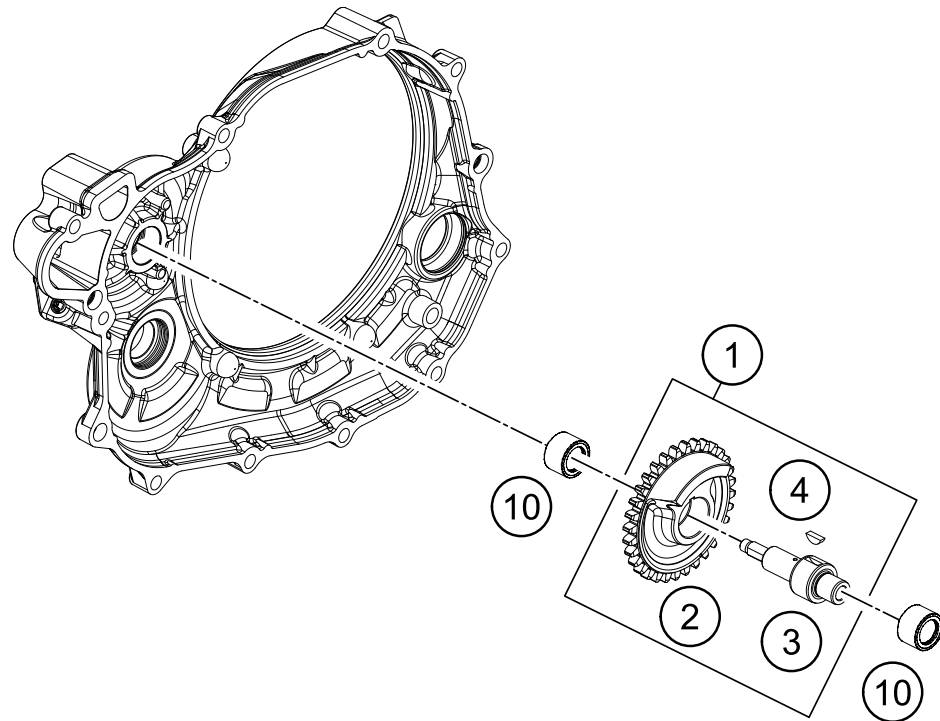

POS	PARTNUMBER	PARTNAME	PIECE
1	78130056100	BALANCE SHAFT	1
2	78130056132	BALANCE SHAFT GEAR	1
3	78130056101	BALANCE SHAFT	1
4	0888030037	WOODRUFF KEY DIN6888-3X3,7	1
10	0618121912	NEEDLE BUSH NK1212	2

137893031

C137893031

* NEW PART

X ON DEMAND

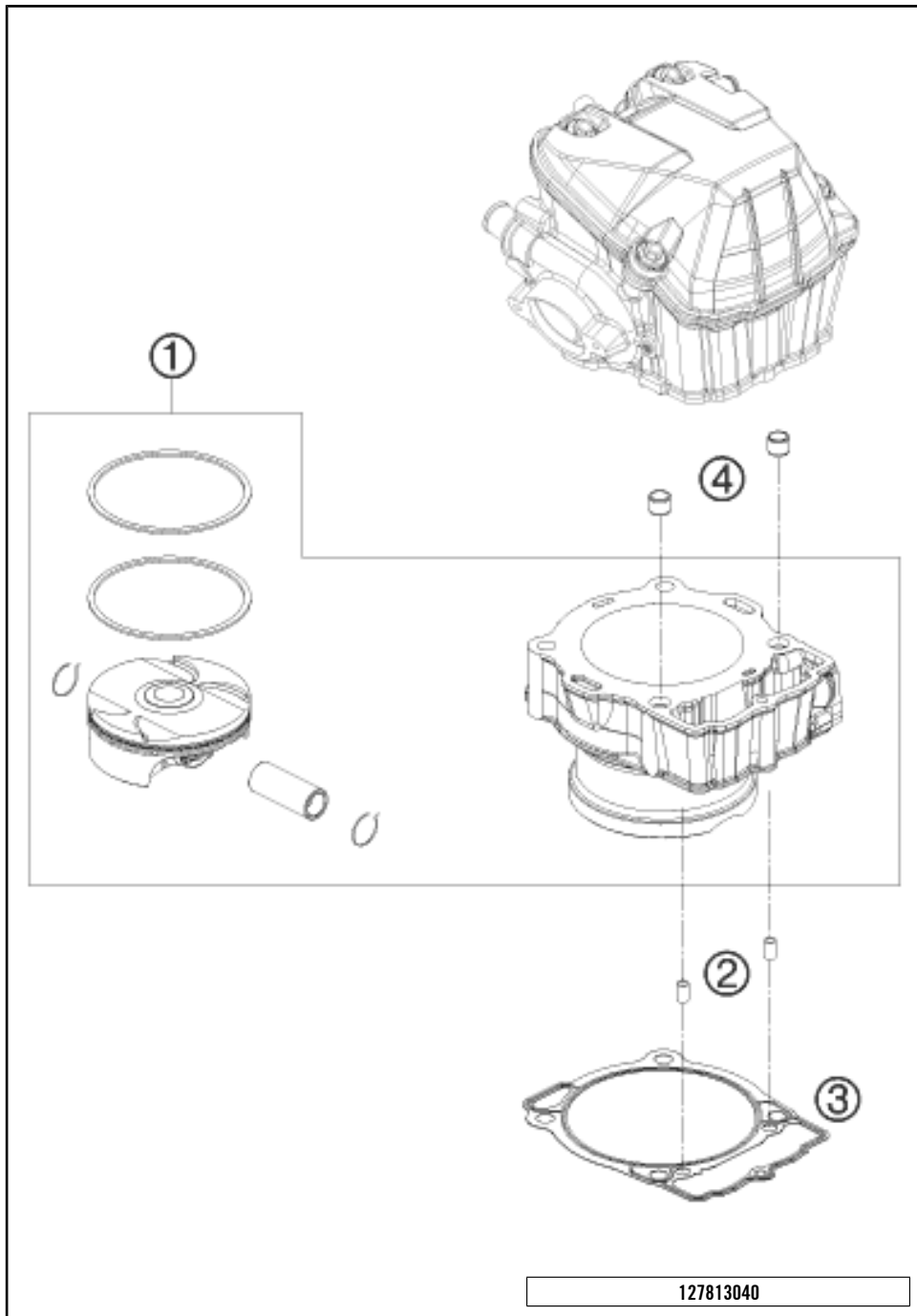

POS	PARTNUMBER	PARTNAME	PIECE
1	78930038100	CYLINDER + PISTON CPL.	1
2	59030023000	DOWEL 6X8X11,5	2
3	78030035000	CYLINDER BASE GASKET	1
4	58530014100	DOWEL BUSHING 10,2X12,5X10	2

127813040

C147893041

* NEW PART

X ON DEMAND

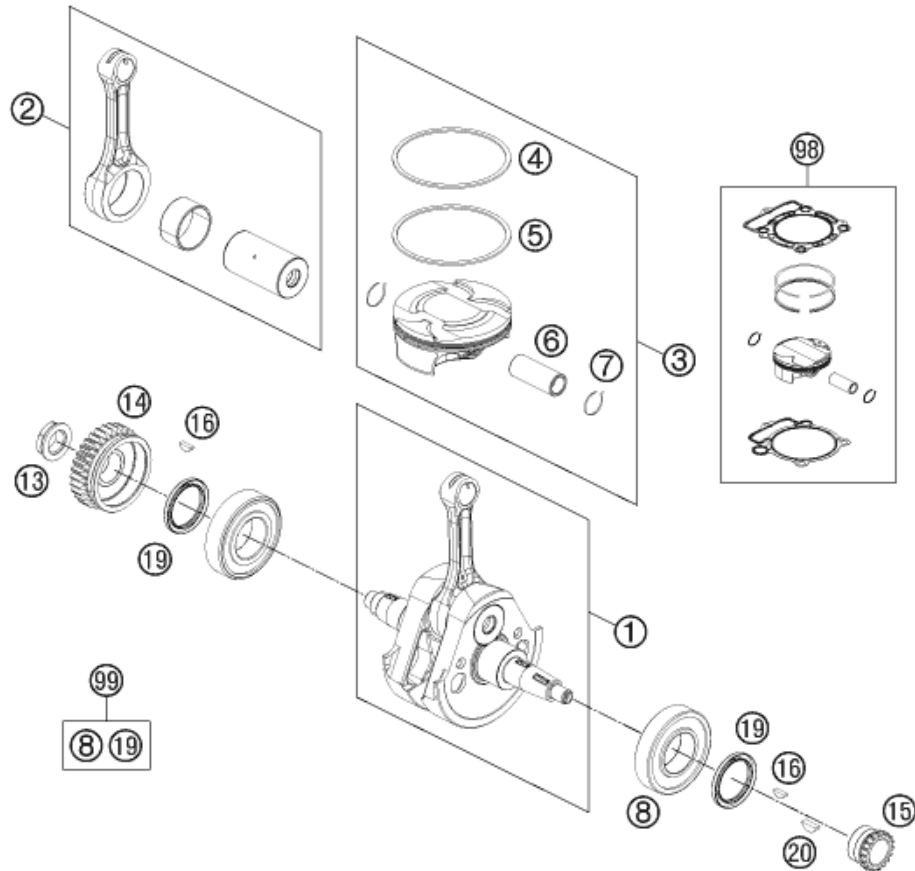

POS	PARTNUMBER	PARTNAME	PIECE
1	78930018000	CRANKSHAFT CPL.	1
2	78930015044	CON. ROD. REP. KIT	1
3	78930007100 I	PISTON D=95MM	1
3	78930007100 II	PISTON D=95MM	1
4	78930030000	COMPRESSION RING	1
5	78930032000	OIL SCRAPER RING	1
6	78930033000	PISTON PIN	1
7	78930074000	CIRCLIP	2
8	0625062071	BALL BEARING 6207 TM-SX07E 39	2
13	78030029200	NUT PRIMARY WHEEL M20X1,5	1
14	78132000032	PRIMARY GEAR	1
15	78036014200	TIMING GEAR 18T.	1
16	0888030037	WOODRUFF KEY DIN6888-3X3,7	2
19	0760354774	SHAFT SEAL RING 35X47X7 VITON	2
20	0888030050	WOODRUFF KEY DIN6888-3X5X13	1
98	00050000218	PISTON KIT GR.I 450 SX-F 13-14	x
98	00050000219	PISTON KIT GR.II 450 SX-F13-14	x
99	00050002310	CRANKSHAFT REP. KIT 450 SX-F13	x

137893060

C147893061

* NEW PART

X ON DEMAND

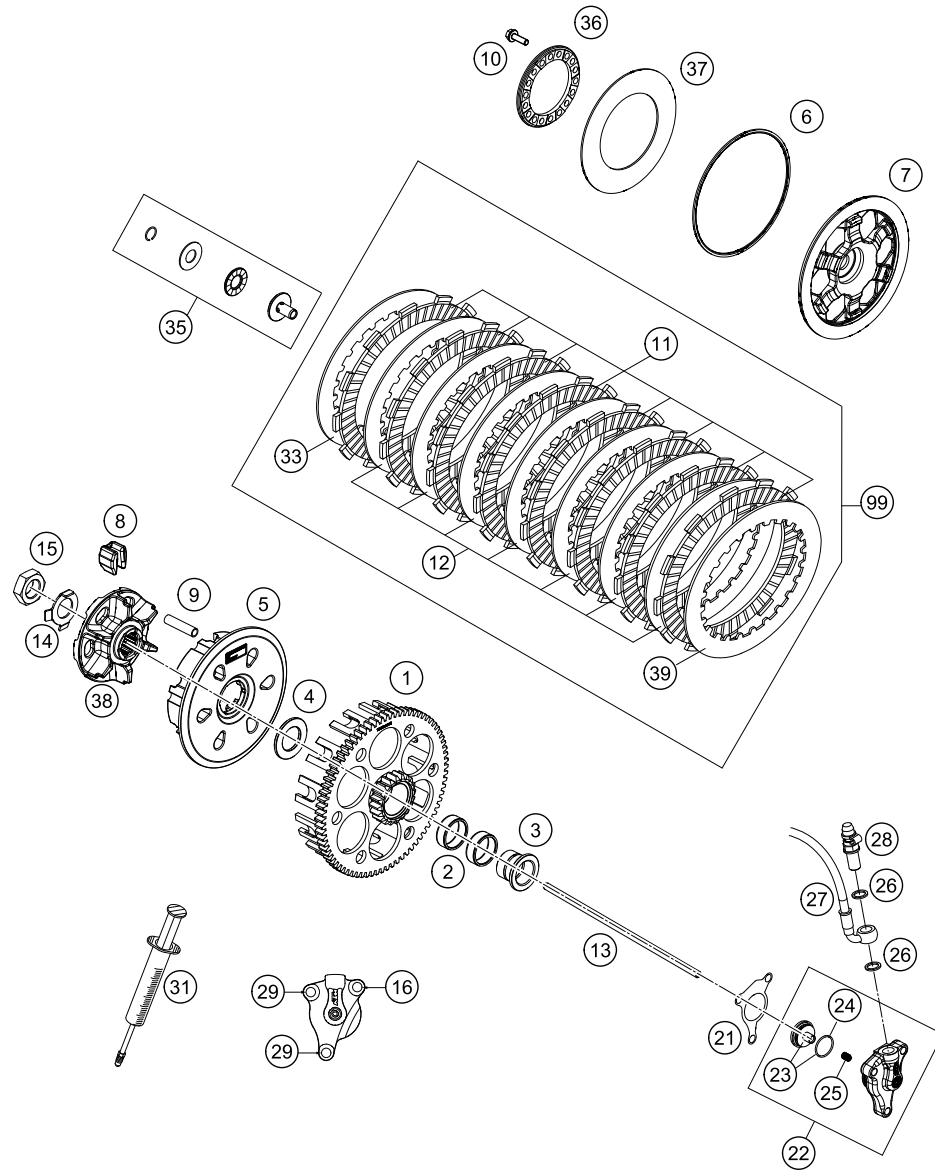

137893212

POS	PARTNUMBER	PARTNAME	PIECE
1	78132001076	CLUTCH CAGE	1
2	0405252910	NEEDLE BEAR K 25X29X10	2
3	78132015100	COLLARSLEEVE	1
4*	78932009000	WASHER 22 X 36,5 X 3	1
5	78132002200	INNER CLUTCH HUB 450SX-F 2014	1
6	78132013000	WASHER 112X118X1.5	1
7*	78132003100	CLUTCH PRESSURE CAP	1
8	78132025100	DAMPING RUBBER	6
9	78132004000	SLEEVE 7,5X33.4	6
10	0025050166	HH COLLAR SCREW M5X16 TX30	6
11	59032011100	LINING DISC 2MM 04	8
12	59032010200	INTERMEDIATE DISC 1,4MM 2002	7
13	78132054100	PUSH ROD	1
14	78132018000	TAB WASHER	1
15	0936181505	HEXAGON NUT DIN0936-M18X1,5 R.	1
16	0025060306	HH COLLAR SCREW M6X30 TX30	1
21*	59032065100	% GASKET F. OUTPUT CYLINDER	1
22	54832061044	OUTPUT CYLINDER CPL. 06	1
23	54832066000	PISTON CPL.	1
24	54832067000	O-RING	1
25	54832069000	PRESSURE SPRING	1
26	0603100141	COPPER GASKET DIN7603-10X14X1	2
27	78132063000	CLUTCH PIPE	1
28	62513020000	BLEEDER SCREW CPL. 05	1
29	0025060206	HH COLLAR SCREW M6X20 TX30	2
31	50329050000	VENT INJEKTION HYDR. CLUTCH	1
33	59032010100	INTERMEDIATE DISC 1MM 2002	1
35*	78132057144	PRESSURE PIECE CPL.	1
36	78132006100	SPRING RING	1
37	78932005000	BELLEV. SPR. 71X115X1,6IO=4.74	1
38	78132002111	HUB	1
39	78932010000	INTERMEDIATE DISC 1MM	1
99	78932010033	CLUTCH DISC KIT	1

C158133210

* NEW PART

X ON DEMAND

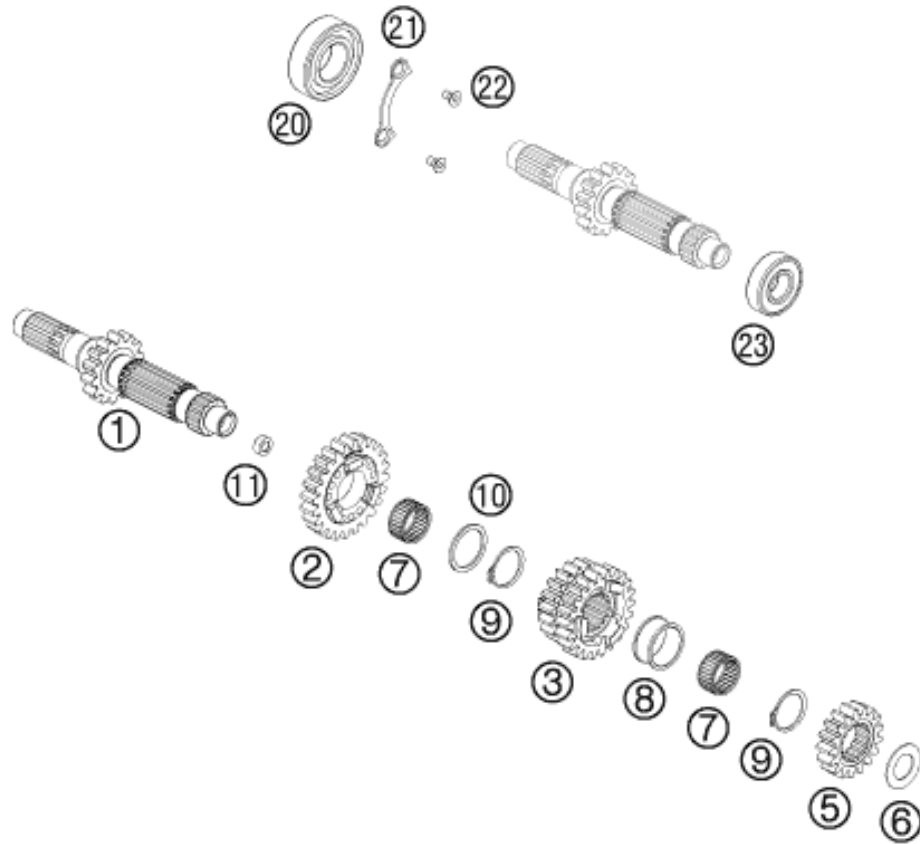

POS	PARTNUMBER	PARTNAME	PIECE
1	78933001050	% MAIN SHAFT 16 T.	1
2	78933005000	IDLER GEAR 5.G.	1
3	78933003000	SLIDING GEAR 3/4 G.	1
5	78933002000	SOLID GEAR 2.G.	1
6	56033030000	STOP DISC 17,2X30X1	1
7	0405222613	NEEDLE BEAR. K 22X26X13 TN	2
8	78933032000	SPACER SLEEVE	1
9	0471250120	CIRCLIP DIN0471-25X1,2	2
10	78033031000	STOP DISK 26 X 32 X 1,5	1
11	78033001110	BUSHING	1
20	0625062054	BALL BEARING 6205 C3 NTN	1
21	78033032000	TAB WASHER BEARING MAIN SHAFT	1
22	0019050106S	INT. TORX FLAT HEAD M5X10 10.9	2
23	0625062036	BALL BEARING 6203 RSH C3	1

137893330

C147893331

* NEW PART

X ON DEMAND

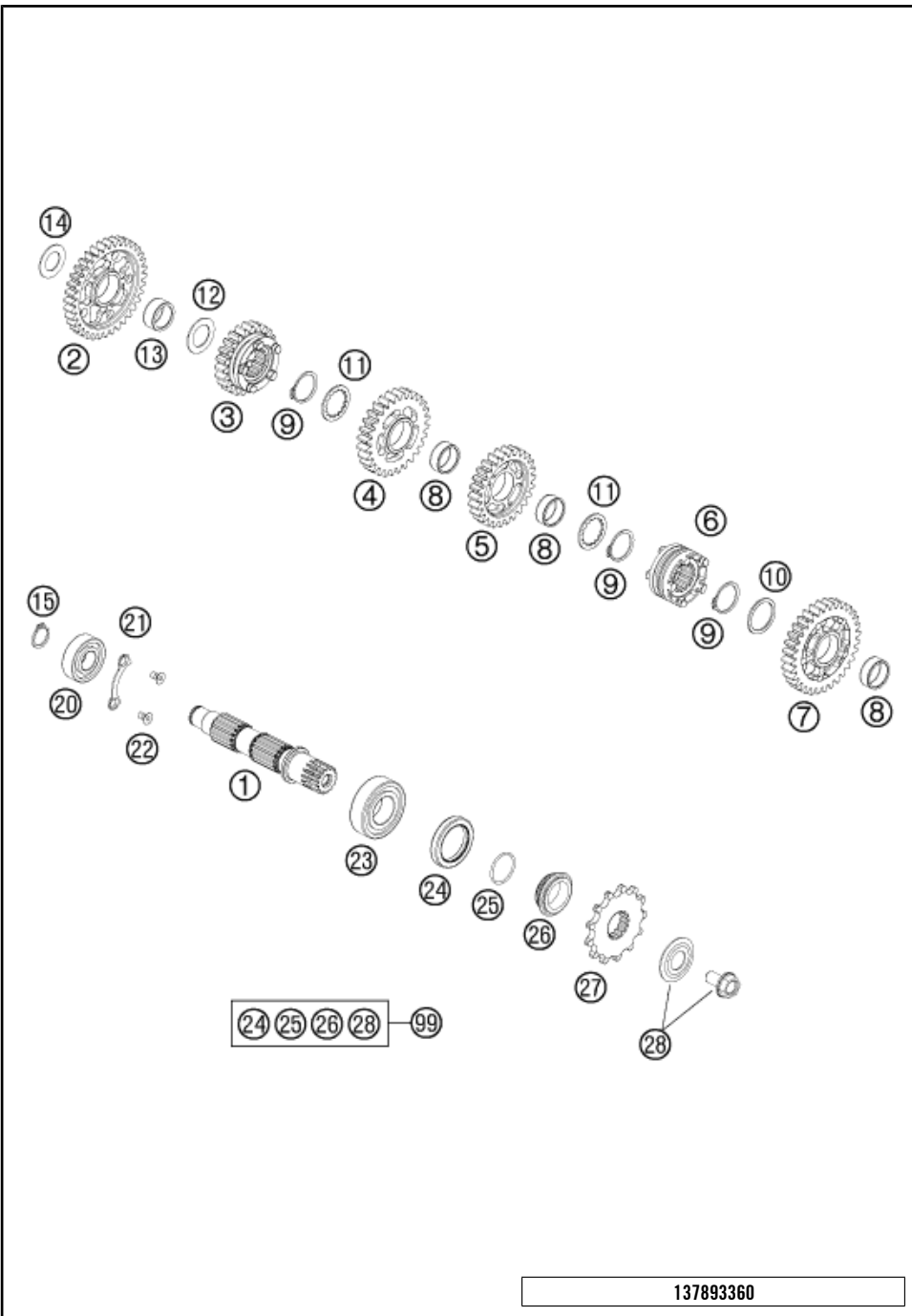

POS	PARTNUMBER	PARTNAME	PIECE
1	78033010000	COUNTERSHAFT 08	1
2	78933011000	IDLER GEAR 1.G.	1
3	78933015000	SLIDING GEAR 5.G.	1
4	78933013000	IDLER GEAR 3.G.	1
5	78933014000	IDLER GEAR 4.G.	1
6	78933018000	SHIFT COLLAR	1
7	78933012000	IDLER GEAR 2.G.	1
8	0405222611	NEEDLE BEAR.K 22X26X10 DIVIDED	3
9	0471250120	CIRCLIP DIN0471-25X1,2	3
10	78033031000	STOP DISK 26 X 32 X 1,5	1
11	78033033000	STOP DISK 23 X 32 X 1,5	2
12	59033080000	SHIM 20X32X1	1
13	0405202612	NEEDLE BEARING K 20X26X12	1
14	56033030000	STOP DISC 17,2X30X1	1
15	0471170015	CIRCLIP DIN 0471-17X1, 5	1
20	0625062035	BALL BEARING 6203 JR2 C3	1
21	78033132000	TAB WASHER BEARING COUNT.SHAFT	1
22	0019050106S	INT. TORX FLAT HEAD M5X10 10.9	2
23	49030023000	CYL.ROLL BEARING NJ205	1
24	0760324571	SHAFT SEAL RING 32X45X7 BSLNBR	1
25	0770020220	O-RING 25,12X1,78 NBR70	1
26	78133014000	SPACER SLEEVE COUNTER	1
27	50033029013	FRONT SPROCKET 13-T	1
27	50033029014	FRONT SPROCKET 14-T	x
27	50033029015	FRONT SPROCKET 15-T	x
28	59033034044	SCREW 10.9+SPRING WASHER	1
99	00050000941	COUNTER SHAFT REP.KIT 4 STROKE	x

137893360

C147893361

* NEW PART X ON DEMAND

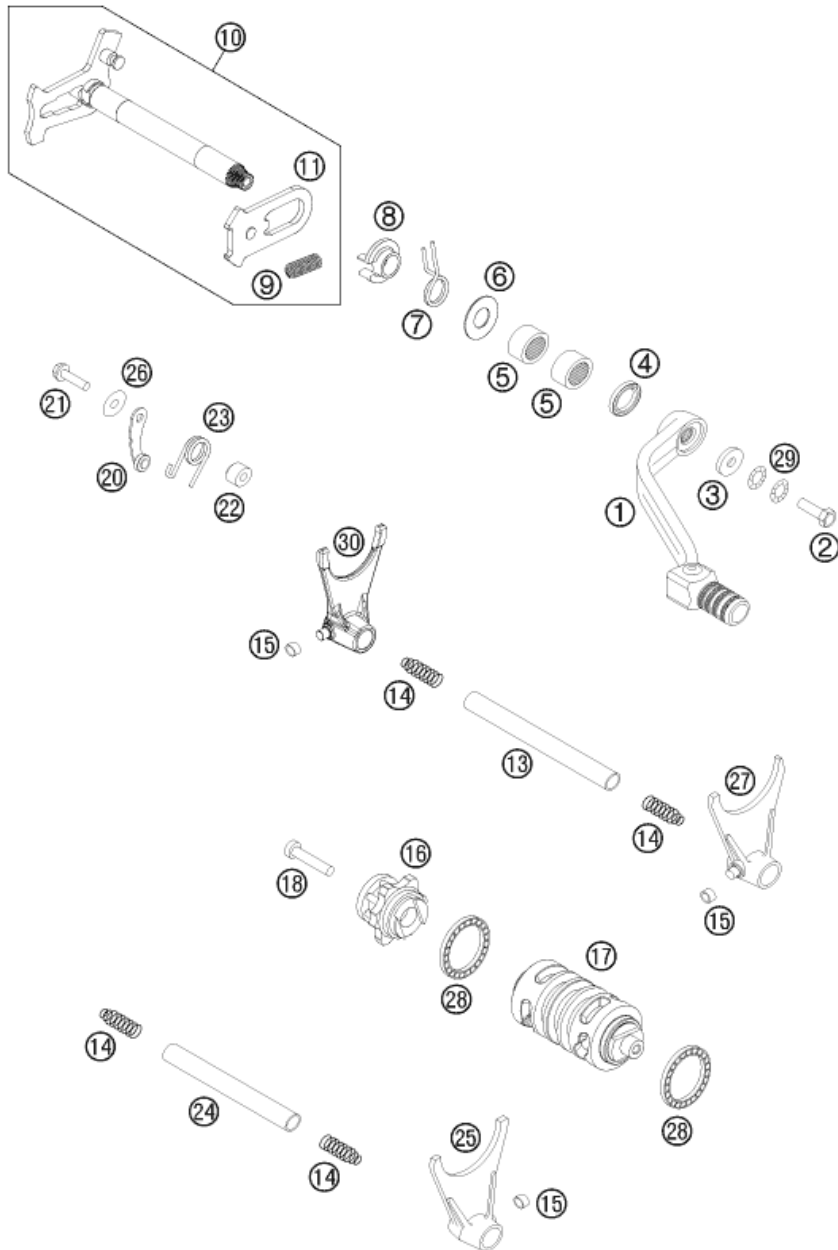

POS	PARTNUMBER	PARTNAME	PIECE
1	59034031000	SHIFT LEVER CPL.RACING 2000	1
2	0025060166S	HH COLLAR SCREW M6X16 ISA 30	1
3	50232050001	STEEL WASHER 6,4X17X3	1
4	0760142460	SHAFT SEAL RING 14X24X6 B	1
5	54632095000	NEEDLE BEAR.HK 1412 14X20X12	2
6	54634050000	STOP DISK 14X30X1	1
7	54634014100	RETURN SPRING 2,2MM '95	1
8	54634020000	SPRING GUIDE	1
9	56534013100	TENSIONING SPRING 0,8MM	1
10	78034005144	% SHIFT SHAFT CPL.	1
11	54634008044	% SLIDING PLATE CPL.	1
13	78034020000	SHIFT RAIL 11,8X101,5	1
14	58038023200	PRESSURE SPRING 0,9MM	4
15	50334018100	SHIFTING ROLLER 6X8X5,2	3
16	78134015044	SHIFT DRUM LOCATING ALU CPL.	1
17	78934112000	SHIFT ROLLER	1
18	0012060303	% AH SCREW DIN6912 M6X30 8.8	1
20	78134024044	LOCKING LEVER CPL.	1
21	0025050206	HH COLLAR SCREW M5X20 TX30	1
22	54634052300	SLEEVE FOR LOCKING LEVER	1
23	60034023000	ARRESTING LEVER SPRING 03	1
24	78034019000	SHIFT RAIL 11,8X85	1
25	59034001100	SHIFTING FORK 5./6. GEAR	1
26	0021050003	WASHER DIN9021-A 5,3	1
27*	59034002100	SHIFTING FORK 2./4. GEAR	1
28	0625618050	BALL BEARING 61805 C3	2
29	50233041000	PAIR OF WASHERS M 6 NORDLOCK	1
30	78034003000	SHIFTING FORK 1ST/3RD GEAR	1

137893410

C157893411

* NEW PART

X ON DEMAND

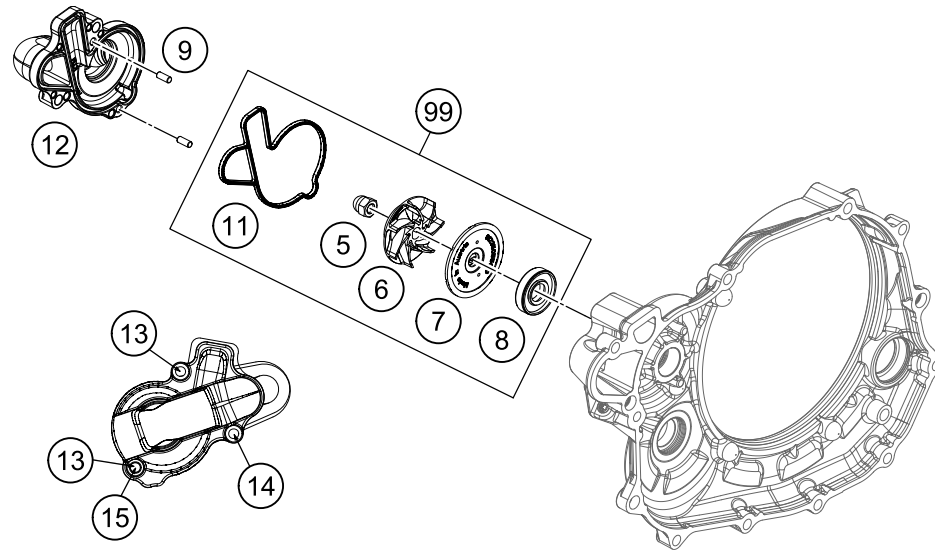

POS	PARTNUMBER	PARTNAME	PIECE
5	61230045000	CAP NUT M6 STAINLESS STEEL	1
6	81235055020	WATER PUMP ROTOR	1
7	81235055110	DISC WATER PUMP	1
8	0760123073	SHAFT SEAL RING 12X30X7 PTFE	1
9	0402040980	NEEDLE ROL.DIN5402 NRB 4X9,8	2
11	78135053000	WATER-PUMP GASKET	1
12	78135052000	WATER PUMP COVER CPL.	1
13	0025060256	HH COLLAR SCREW M6X25 TX30	2
14	0025060656	HH COLLAR SCREW M6X65 TX30	1
15	0603061001	CU-SEAL RING DIN7603-6X10X1	1
99	81235055015	WATER PUMP REP. KIT 12-14	x

137893511

C137893511

* NEW PART

X ON DEMAND

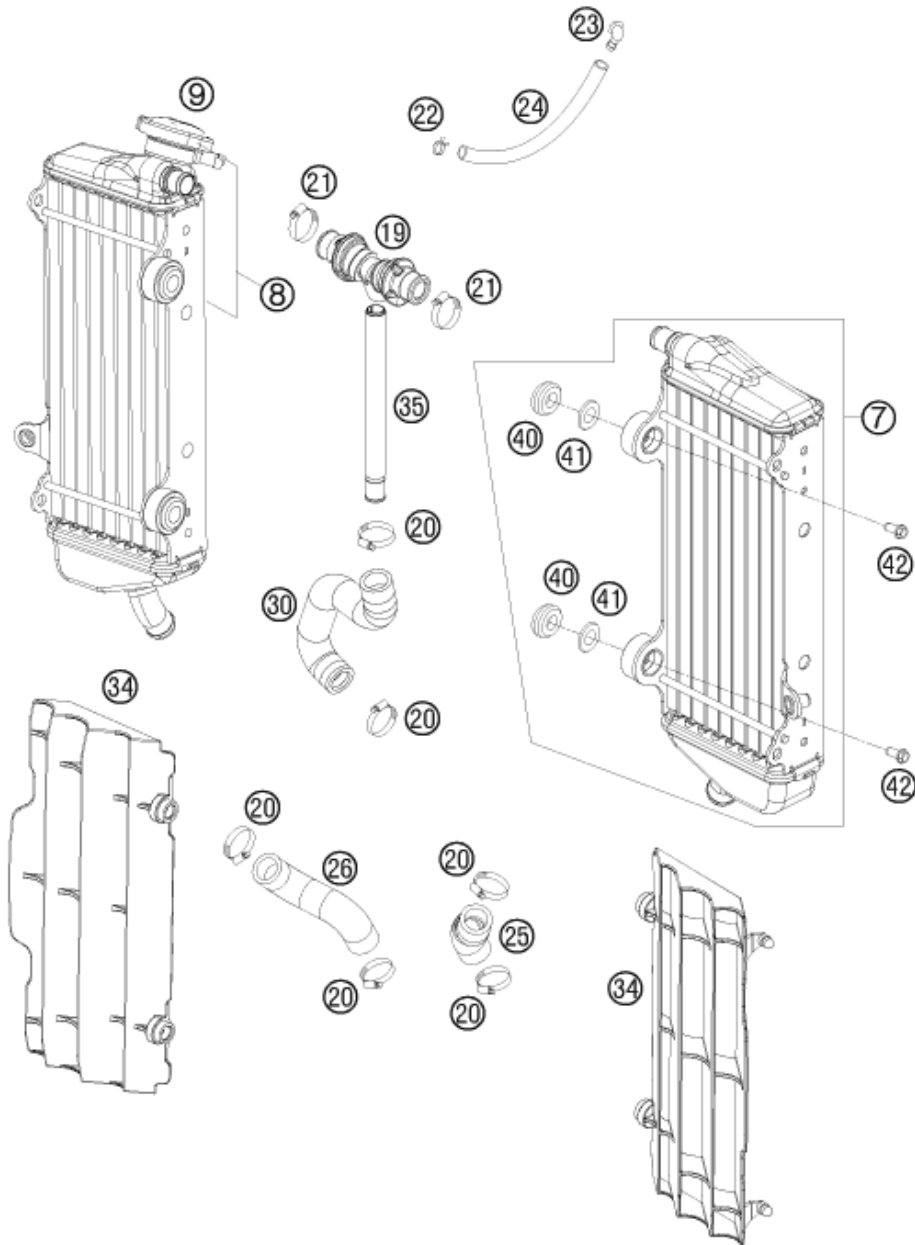

POS	PARTNUMBER	PARTNAME	PIECE
7	77035007300	% RADIATOR L/S "55623U" 12	1
8	77235008100	% RADIATOR R/S "55637U" 13	1
9	77335016000	RADIATOR CAP SMALL 1,8 BAR	1
19	77235071044	Y-CONNECTOR CPL.	1
20	10001020000	HOSE CLAMP GEMI 18-29	6
21	42013037400	HOSE CLAMP NORMA 14/24	2
22	59007017000	CLAMP YDNAC 10096F (9,6MM)	1
23	50303089000	ANGLE PIECE '97	1
24	50335030001	PVC-HOSE 6X9	x
25	78135025000	RADIATOR HOSE L/S 2012	1
26	78135027000	RADIATOR HOSE R/S 2012	1
30	78935024000	PREFORMED HOSE ENGINE/COOLER	1
34	7733503400030	RADIATOR PROTECTION BLACK 07	2
35	77235073000	HOSE CONNECTOR L=172,5	1
40	41001052000	RUBBER SLEEVE D=12MM	4
41	77335001000	WASHER FOR RADIATOR 08	4
42	0023060123	COLLAR SCREW M6X12 TX	4

137893530

C137893531

* NEW PART

X ON DEMAND

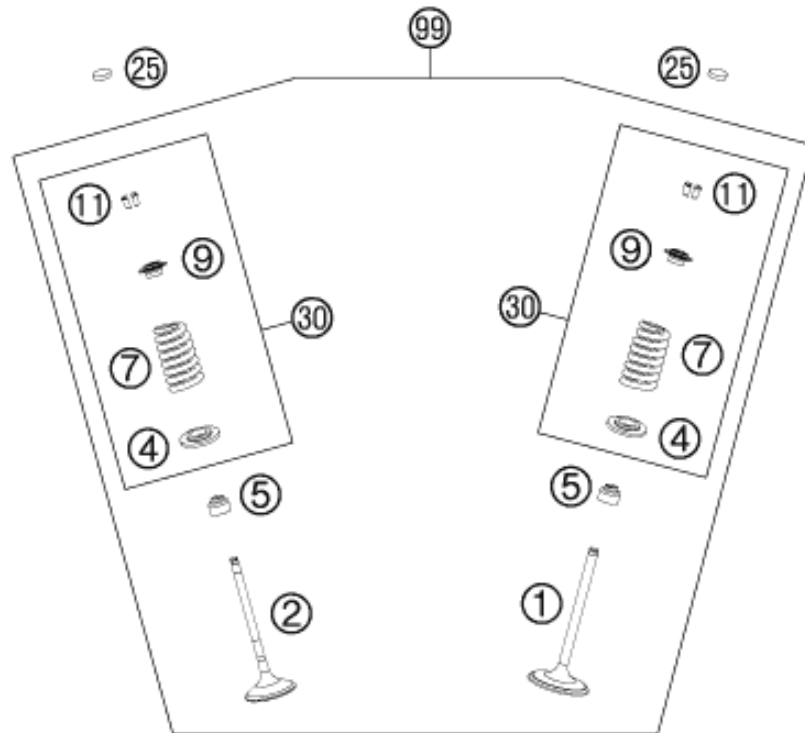

AUSLASS / EXHAUST

EINLASS / INTAKE

POS	PARTNUMBER	PARTNAME	PIECE
1	78936030100	INTAKE VALVE	2
2	78936031000	EXHAUST VALVE	2
4	78936036000	VALVE SPRING HOLDER	4
5	59036027000	VALVE-STEM SEALING RACING	4
7	78936028000	VALVE SPRING	4
9	78936032000	VALVE SPRING RETAINER	4
11	77336033100	VALVE COLLET 07	8
15	78936061044	ROCKER ARM EXHAUST CPL.	1
18	78936056000	ROCKER ARM SHAFT INTAKT	1
19	78936057000	ROCKER ARM SHAFT EXHAUST	1
20	78936060000	ROCKER ARM INTAKE	1
21	0770150151	O-RING 15,00X1,50 VITON	2
22	78936081000	SCREW M18X1,5	2
23	77036080000	SPECIAL SCREW M7X40 WS10	2
24	78036080000	FIT BOLT M7X1X55	2
25	77036035172	SHIM D=8,9/1,72	x
25	77036035176	SHIM D=8,9/1,76	x
25	77036035180	SHIM D=8,9/1,80	x
25	77036035184	SHIM D=8,9/1,84	x
25	77036035188	SHIM D=8,9/1,88	x
25	77036035192	SHIM D=8,9/1,92	x
25	77036035196	SHIM D=8,9/1,96	x
25	77036035200	SHIM D=8,9/2,00	x
25	77036035204	SHIM D=8,9/2,04	x
25	77036035208	SHIM D=8,9/2,08	x
25	77036035212	SHIM D=8,9/2,12	x
25	77036035216	SHIM D=8,9/2,16	x
25	77036035220	SHIM D=8,9/2,20	x
25	77036035224	SHIM D=8,9/2,24	x
25	77036035228	SHIM D=8,9/2,28	x
25	77036035232	SHIM D=8,9/2,32	x
25	77036035236	SHIM D=8,9/2,36	x
25	77036035240	SHIM D=8,9/2,40	x
25	77036035244	SHIM D=8,9/2,44	x
25	77036035248	SHIM D=8,9/2,48	x
25	77036035252	SHIM D=8,9/2,52	x
25	77036035256	SHIM D=8,9/2,56	x
25	77036035260	SHIM D=8,9/2,60	x

137893610

C147893610

* NEW PART

X ON DEMAND

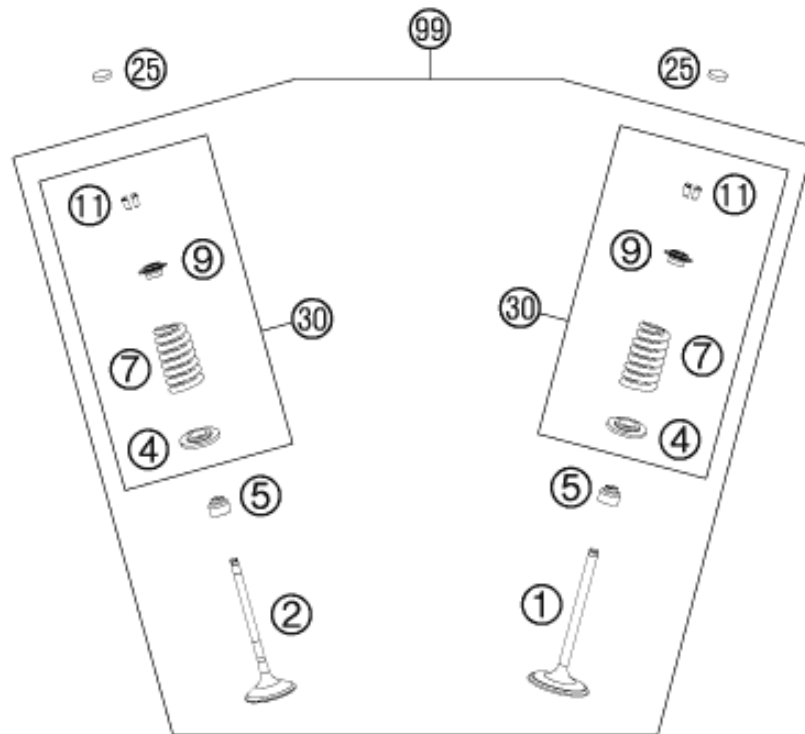

AUSLASS / EXHAUST

EINLASS / INTAKE

POS	PARTNUMBER	PARTNAME	PIECE
30	78936029044	VALVE SPR.-KIT 450 SX-F 13	X
99	78936030110	VALVE KIT 450 HQV 14	X

137893610

C147893610

* NEW PART

X ON DEMAND

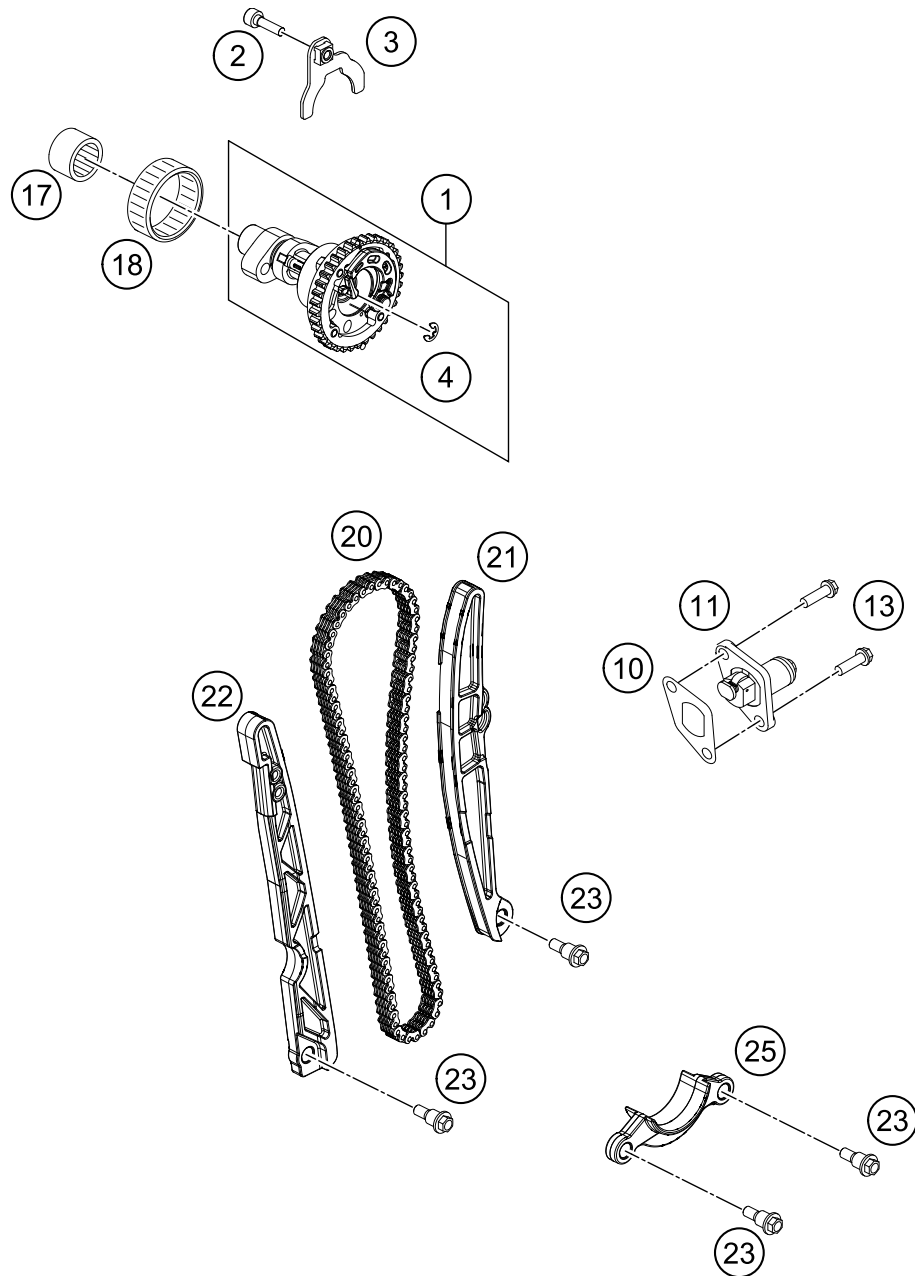

POS	PARTNUMBER	PARTNAME	PIECE
1	78936010133	CAMSHAFT W. AUTODECO	1
2	0025060206S	HH COLLAR SCREW M6X20 TX30	1
3	78036012033	RETAINING PLATE CAMSHAFT CPL.	1
4	0799050000	TAB WASHER DIN6799 RS5	1
10*	59036003150	%GASKET TIMING CHAIN TENSIONER	1
11	59036003000	TIMINGCHAIN TENSIONER CPL.RAC.	1
13	0025060166	HH COLLAR SCREW M6X16 TX30	2
17	0618182414	NEEDLE SLEEVE HK1814RS18/24/14	1
18	0618404712	NEEDLE SLEEVE HK4012B40X47X12	1
20	78036013000	TIMING CHAIN 110T 08	1
21	78136002100	TIMING CHAIN TENSIONER	1
22	78136001000	TIMING CHAIN GUIDE	1
23	77236001160	BUSHING SCREW M6	4
25	78136018000	FAILURE PROTECTION	1

147893620

C158133620

* NEW PART

X ON DEMAND

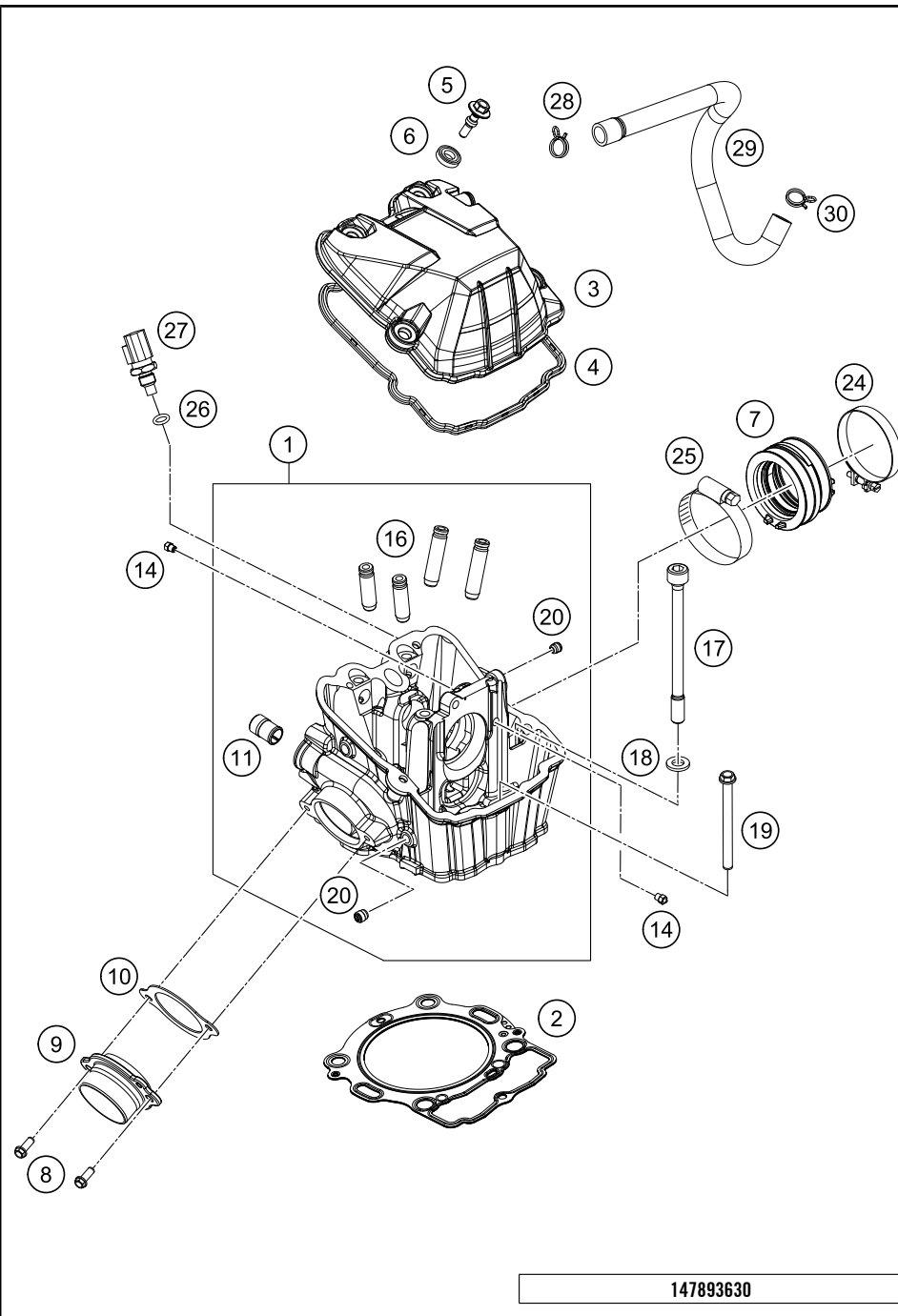

POS	PARTNUMBER	PARTNAME	PIECE
1	78936020044	CYLINDER HEAD CPL.	1
2	78930036010	CYLINDER HEAD GASKET S=1.0	1
3	78036052000DA	VALVE COVER	1
4	78036053100	VALVE COVER GASKET	1
5	78036054100	VALVE COVER SCREW	4
6	75036052010	DECOUPLING ELEMENT 07	4
7	77736044000	RUBBER BOOT EFI	1
8	0025060166S	HH COLLAR SCREW M6X16 ISA 30	2
9	78136139000	EXHAUST FLANGE	1
10	78036041000	EXHAUST FLANGE GASKET	1
11	58030010200	SCREW IN NOZZLE M20X1,5	1
14	60030063070	OIL JET 70 M5	2
16	78136025001	VALVE GUIDE INTAKE	4
17	78030044000	CYL. HEAD SCREW M10X1,25 L=125	4
18	77336089010	WASHER 19X10,5X2,5	4
19	0025060706	HH COLLAR SCREW M6X70 TX30	1
20	59030296000	SCREW PLUG	3
24	61036047000	HOSE CLAMP GEMI 63MM 05	1
25	77236048000	HOSE CLAMP GEMI 58MM	1
26	0770100020	O-RING 10,00X2,00 SILCONE	1
27	60011252000	TEMPERAT.-SENSOR WATER LC8 02	1
28	58431082300	CLAMP YDNAC 10173 (18MM)	1
29	78130087000	ENGINE BREATHER TUBE	1
30	58431082100	YDNAC-CLAMP 10173 (16MM) '98	1

147893630

C147893630

* NEW PART

X ON DEMAND

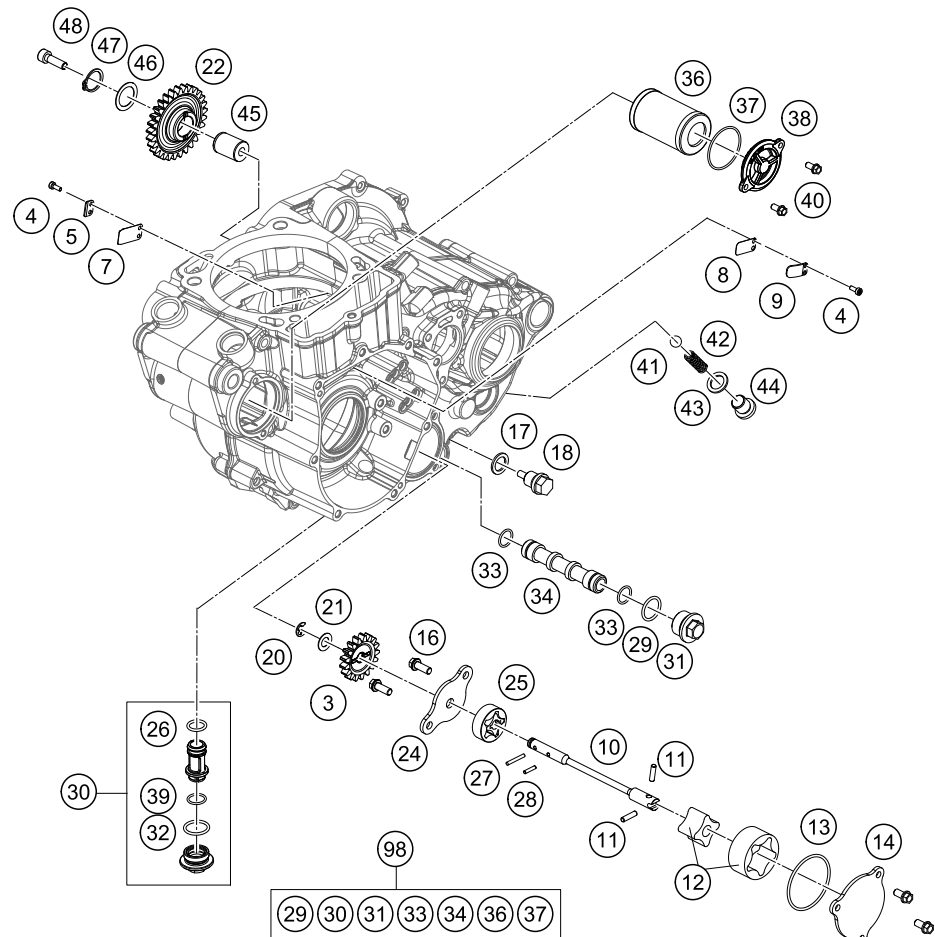

POS	PARTNUMBER	PARTNAME	PIECE
3	78038001017	OIL PUMP GEAR 17 T	1
4	0458030080	CYLIND.SCREW M3X8 ISO 14580 SS	4
5	75030003050	STOP SHEET MEMBRANE 07	1
7	75030003051	MEMBRANE 07	1
8	81205027003	MEMBRAN CRANKCASE	1
9	81205027004	TAB WASHER MEMBRAN CSC	1
10	78138102000	OIL PUMP SHAFT SP-DP	1
11	0402041580	NEEDLE ROLLER NRB 4X15,8 G2	2
12	61238111000	ROTOR-SET CPL. 22MM	1
13	0770440020	O-RING 44,00X2,00 VITON	1
14	78038004000	OIL PUMP COVER SUCTION PUMP	1
16	0025060166S	HH COLLAR SCREW M6X16 ISA 30	2
17	58038022000	CU-SEAL RING DIN7603-12X18X1,5	1
18	58030021000	OILDRAIN PLUG W.MAG. M 12X1,5	1
20	0799060000	TAB WASHER DIN6799-RS 6,0	1
21	58038007755	STOP DISK 8,1 X 15 X 0,5	1
22	78138001029	IDLER GEAR 1 29Z	1
24	78138003000	OIL PUMP COVER	1
25	59038011012	OILPUMP ROTOR 12MM G-95R/003	1
26	0770012021	O-RING 12X2 VITON GREEN	1
27	0402251980	NEEDLEROL.DIN5402 NRA 2,5X19,8	1
28	0402251180	NEEDLE ROLLER DIN5402 2,5X11,8	1
29	0770020170	O-RING 17,17X1,78 GLO	1
30	78138015001	OIL SCREEN CPL.	1
31	59038017000	PLUG M20X1,5 WS=13	1
32	0770170200	O-RING 17,00X2,00	1
33	07701250151	O-RING 12,5X1,5 VITON V75	2
34	59038016100	OIL SCREEN	1
36	77038005044	OIL FILTER WITH GASKET 06	1
37	07700390261	O-RING 39,34X2,62	1
38	75038041200	OILFILTER CAP	1
39	0770125015	O-RING 12,5X1,5 NBR	1
40	0025050166	HH COLLAR SCREW M5X16 TX30	5
41	0401090003	BALL DIN5401-9	1
42	58038023300	PRESSURE SPRING L=25MM D=1MM	1
43	58038022000	CU-SEAL RING DIN7603-12X18X1,5	1
44	78036024000	PLUG SCREW SAS M12X1,5	1
45	78040028000	BUSHING PIN	1

137893811

C137893811

* NEW PART

X ON DEMAND

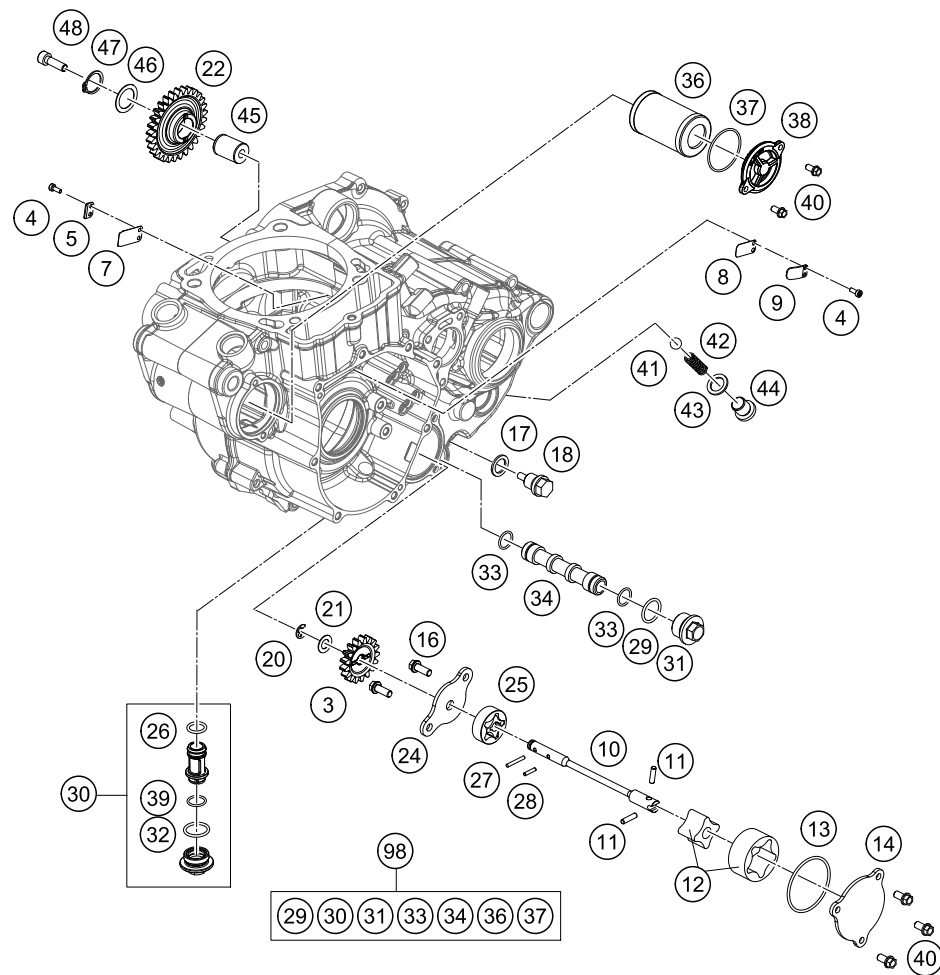

POS	PARTNUMBER	PARTNAME	PIECE
46	0988172405	SHIM WASHER DIN0988-17X24X0,5	1
47	0471170010	CIRCLIP DIN0471-17X1	1
48	0912060208	AH SCREW DIN0912-M 6X20 SS	1
98	78938015010	OILFILTER SERVICEKIT SX-F 15	x

137893811

C137893811

* NEW PART

X ON DEMAND

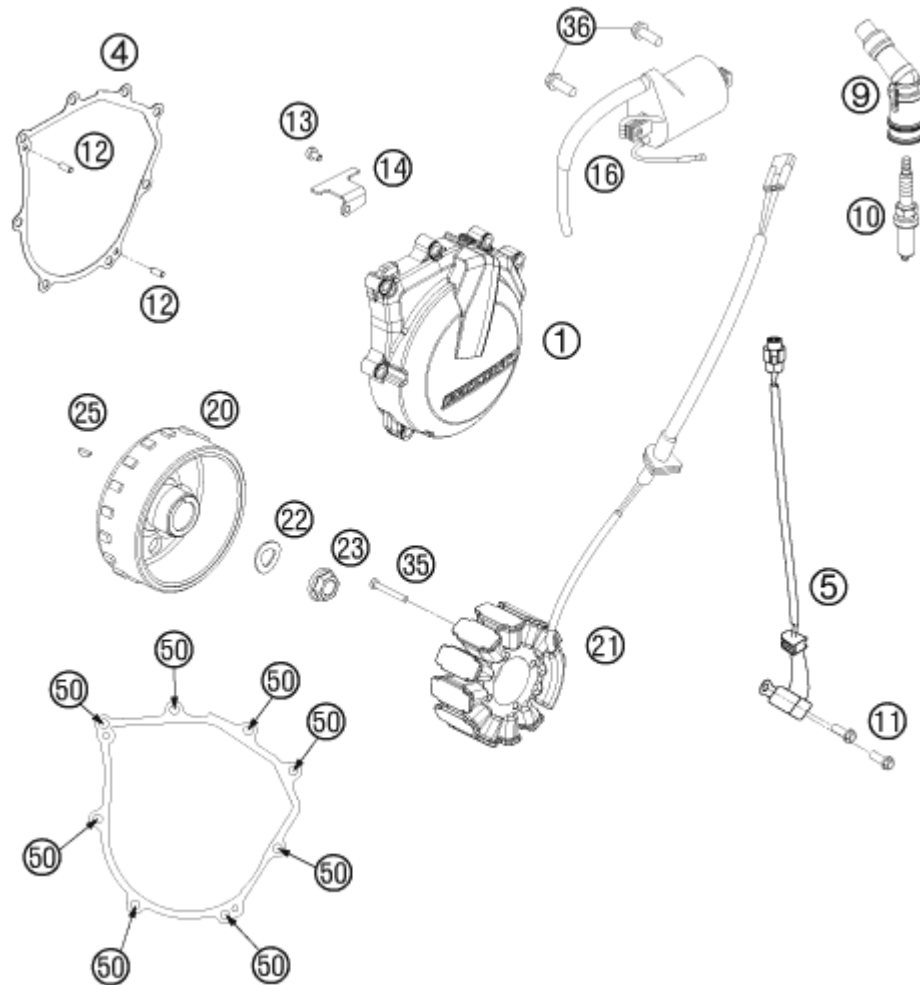

POS	PARTNUMBER	PARTNAME	PIECE
1	78930002100KA	IGNITION COVER	1
4	78130040000	GASKET - IGNITION COVER	1
5	59039034000	PULSER COIL KOKUSAN 4K3-A/B	1
9*	78039090100	SPARK PLUG CONNECTOR	1
10	75039093000	SPARK PLUG M12X1,25 LKAR8AI-9	1
11	0025050166	HH COLLAR SCREW M5X16 TX30	2
12	0402040980	NEEDLE ROL.DIN5402 NRB 4X9,8	2
13	0019040106S	FLAT HEAD SCREW ISA25 M4X10	1
14	81230002010	RETAINING PLATE	1
16	58439006000	IGNITIONCOIL IG3826 KOKUSAN'96	1
20	78939005000	ROTOR	1
21	78939004000	STATOR	1
22	0137120000	SPRING WASHER DIN0137-B12	1
23	49030021000	COLLAR NUT M12X1 R/S	1
25	0888030050	WOODRUFF KEY DIN6888-3X5X13	1
35	0012040303	AH SCREW DIN6912 M4x30	4
36	0026060186	COLLAR SCREW M6X18 ISA30	2
50	0025060256	HH COLLAR SCREW M6X25 TX30	8

137893910

C158133910

* NEW PART

X ON DEMAND

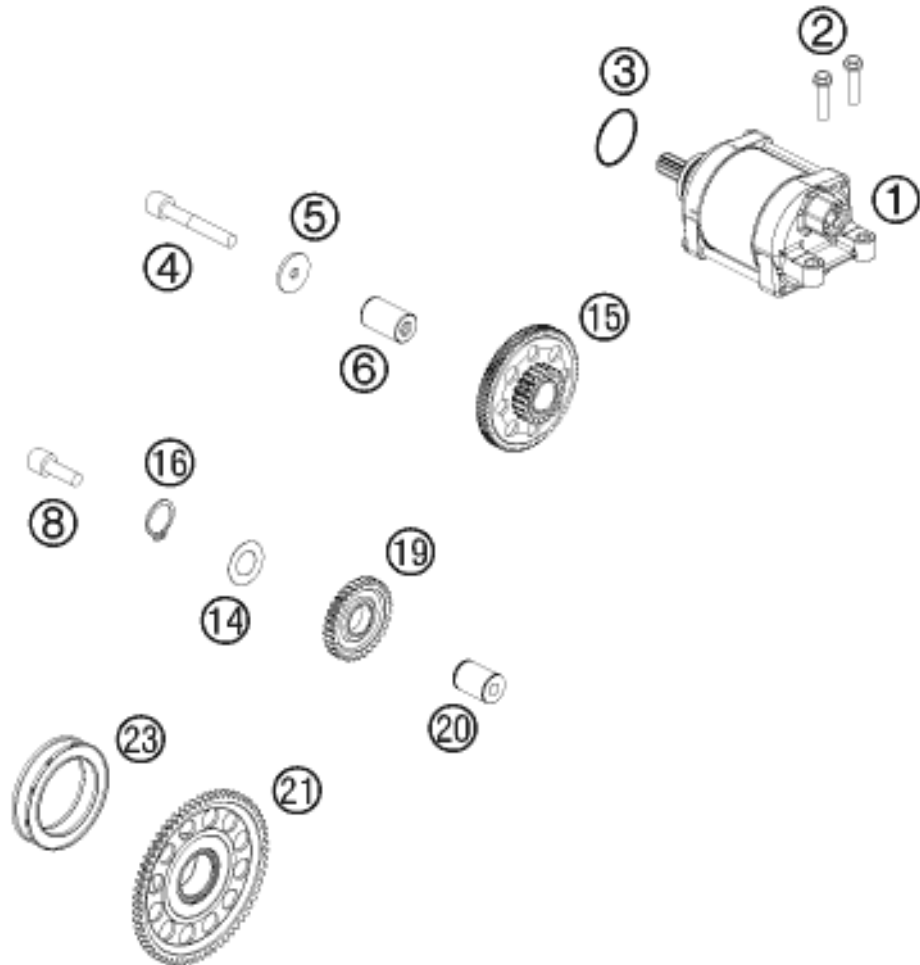

POS	PARTNUMBER	PARTNAME	PIECE
1	78140001000	E-STARTER CPL. 0,5KW	1
2	0025060256	HH COLLAR SCREW M6X25 TX30	2
3	0770250030	O-RING 25,00X3,00 NBR 70	1
4	0912060404	AH SCREW DIN0912-M 6X40 A2	1
5	78040016004	STOP DISC 6X23X2	1
6	78040029000	BEARING BOLT	1
8	0912060208	AH SCREW DIN0912-M 6X20 SS	1
14	0988172405	SHIM WASHER DIN0988-17X24X0,5	1
15	78040016100	TORQUE LIMITER CPL.	1
16	0471170010	CIRCLIP DIN0471-17X1	1
19	78940022000	IDLER GEAR 30-T CPL.	1
20	78040028000	BUSHING PIN	1
21	78940020033	FREEWHEEL GEAR 66 C CPL.	1
23	75040026000	FREE WHEEL	1

137894010

C137894010

* NEW PART

X ON DEMAND

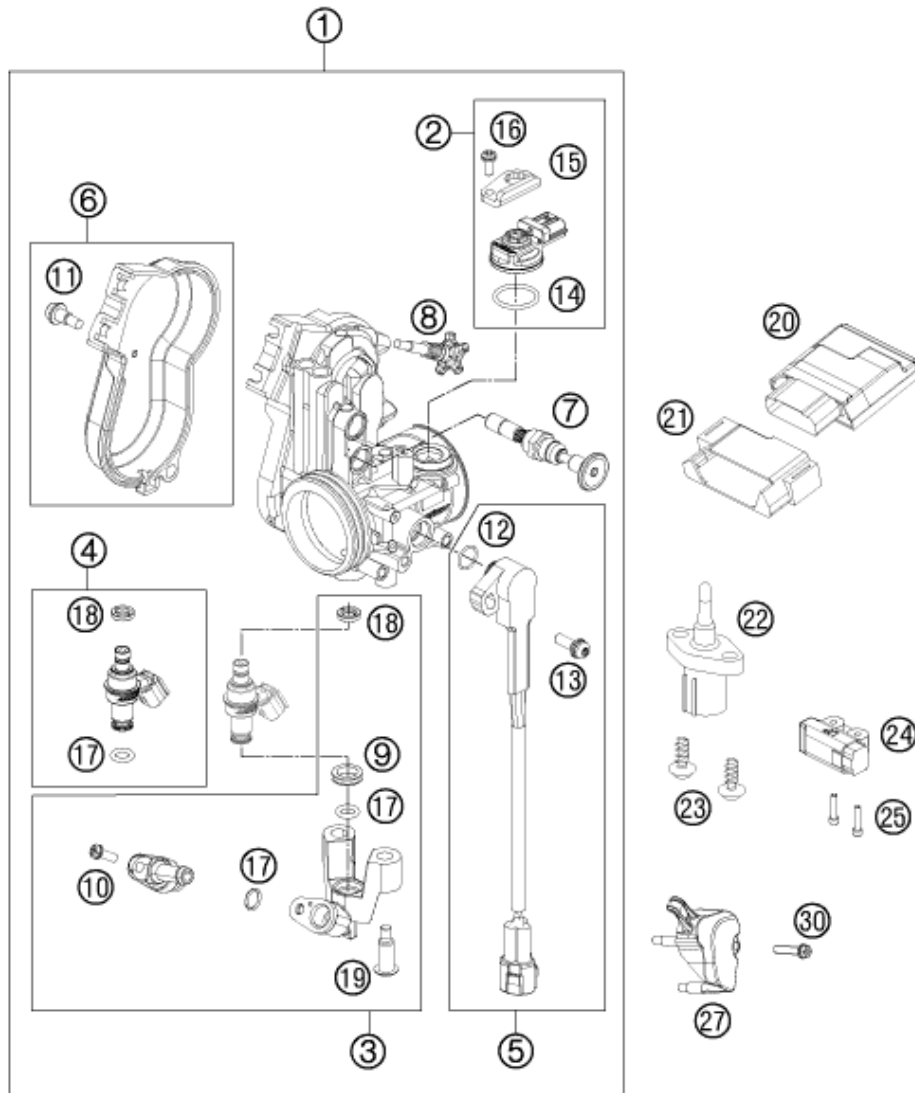

POS	PARTNUMBER	PARTNAME	PIECE
1	77741001000	THROTTLE BODY	1
2	75041085044	MAP SENSOR CPL. 07	1
3	77741013044	FUEL RAIL CPL.	1
4	77741023044	INJECTOR KIT CPL.	1
5	77741077044	TPS CPL.	1
6	81241056044	THROTTLE COVER CPL. 09	1
7	77741070000	STARTER VALVE COMP.	1
8	77741060044	IDLING ADJUSTING SCREW CPL.	1
9	77741023030	SEAL RING	1
10	75041013010	SCREW SHOULDER	1
11	81241056020	SPECIAL SCREW AH	2
12	61041077010	O-RING THROTTLE POS. SENSOR	1
13	81241077030	SPECIAL SCREW	1
14	75041085010	O-RING	1
15	77741085020	PLATE	1
16	81241085030	SPECIAL SCREW	1
17	75041023020	O-RING 7,2x2,2	2
18	75041023010	SEAL RING	1
19	75041013060	SCREW SHOULDER	2
20	81241031000	% TIMING CHARGER EFI	1
21	77241035050	ECU SAFETY COVER	1
22	61041080000	AMBIENT-AIR TEMPERATURE SENSOR	1
23	0025050166	HH COLLAR SCREW M5X16 TX30	2
24	61041088000	ROLLOVER SENSOR 05	1
25	0025060206	HH COLLAR SCREW M6X20 TX30	2
27	77741077050	PROTECTION CAP TPS	1
30	0025050256	HH COLLAR SCREW M5X25 ISA30	1

137894110

C147894111

* NEW PART

X ON DEMAND

A large, empty rectangular box with a thin black border, occupying the majority of the page. It is intended for handwritten or typed notes.

A large, empty rectangular box with a thin black border, occupying the majority of the page. It is intended for handwritten notes.



3CM0895770EN



Husqvarna Motorcycles GmbH
Stallhofnerstraße 3 | 5230 Mattighofen | Austria
www.husqvarna-motorcycles.com



THE PIONEERS OF MOTOCROSS