

SPARE PARTS MANUAL: CHASSIS



ART.NO.: 3CF2375L9EN

ENGLISH



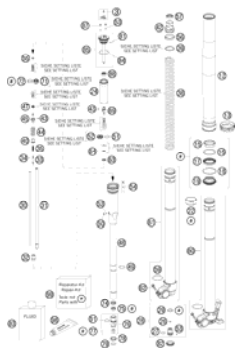
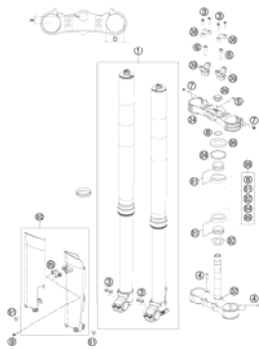
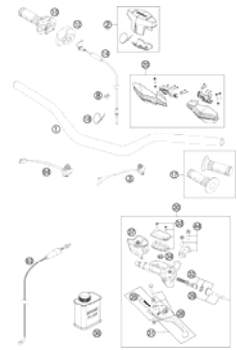
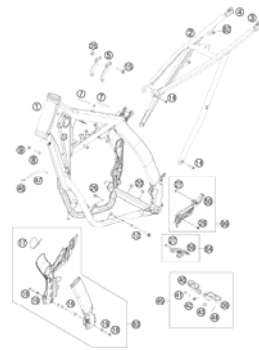
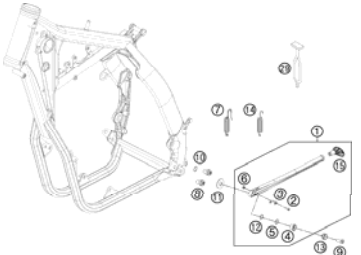
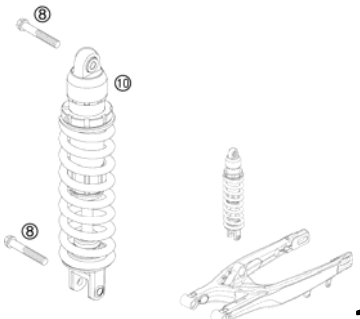
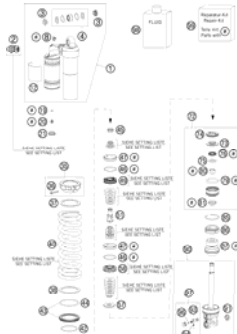
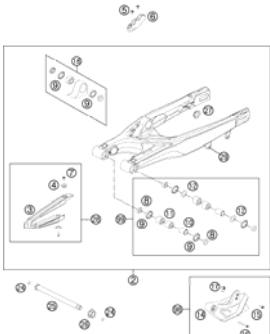
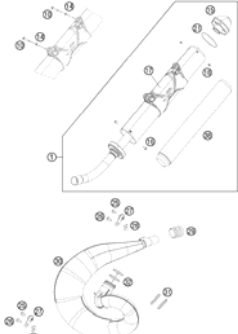
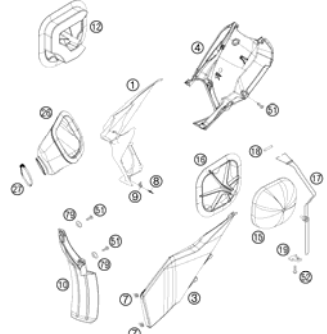
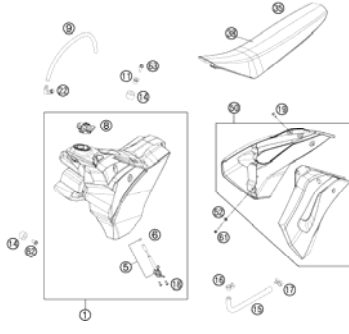
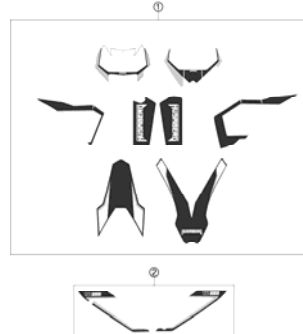

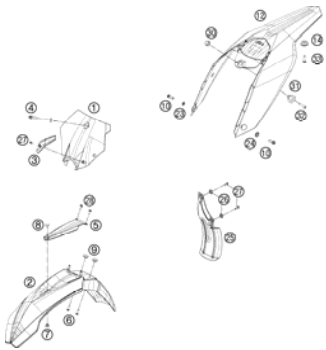
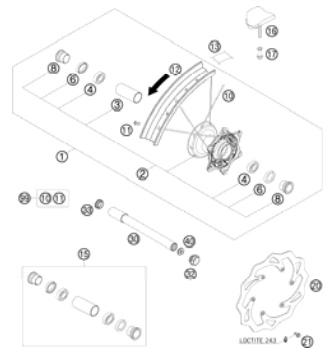
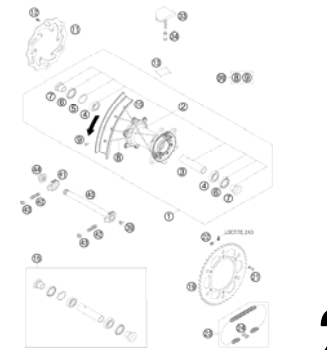
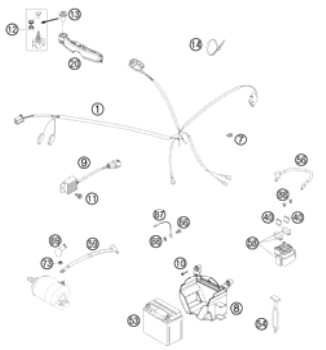
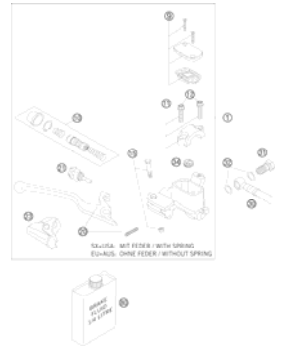
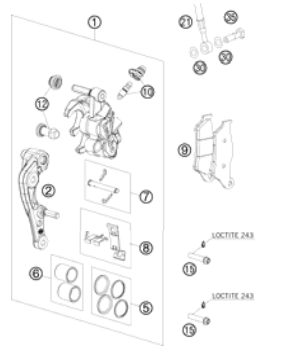
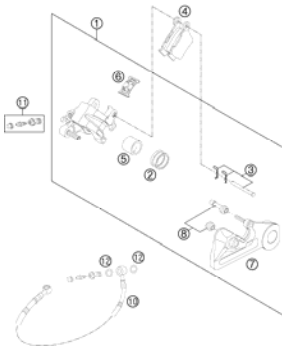
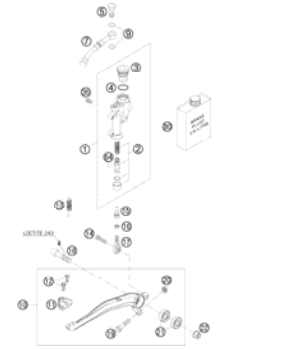
<p><b>FRONT FORK DISASSEMBLED</b></p>  <p><b>4</b></p>	<p><b>FRONT FORK, TRIPLE CLAMP</b></p>  <p><b>6</b></p>	<p><b>HANDLEBAR, CONTROLS</b></p>  <p><b>7</b></p>	<p><b>FRAME</b></p>  <p><b>8</b></p>
<p><b>SIDE / CENTER STAND</b></p>  <p><b>9</b></p>	<p><b>SHOCK ABSORBER</b></p>  <p><b>10</b></p>	<p><b>SHOCK ABSORBER DISASSEMBLED</b></p>  <p><b>11</b></p>	<p><b>SWING ARM</b></p>  <p><b>13</b></p>
<p><b>EXHAUST SYSTEM</b></p>  <p><b>14</b></p>	<p><b>AIR FILTER</b></p>  <p><b>15</b></p>	<p><b>TANK, SEAT, COVER</b></p>  <p><b>16</b></p>	<p><b>DECAL</b></p>  <p><b>17</b></p>

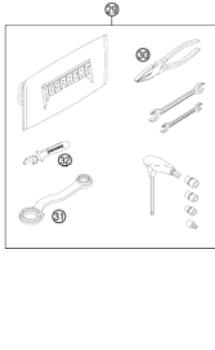
<p><b>MASK, FENDERS</b></p>  <p><b>18</b></p>	<p><b>FRONT WHEEL</b></p>  <p><b>19</b></p>	<p><b>REAR WHEEL</b></p>  <p><b>20</b></p>	<p><b>WIRING HARNESS</b></p>  <p><b>21</b></p>
<p><b>HAND BRAKE CYLINDER</b></p>  <p><b>22</b></p>	<p><b>BRAKE CALIPER FRONT</b></p>  <p><b>23</b></p>	<p><b>BRAKE CALIPER REAR</b></p>  <p><b>24</b></p>	<p><b>REAR BRAKE CONTROL</b></p>  <p><b>25</b></p>
<p><b>INSTRUMENTS / LOCK SYSTEM</b></p>  <p><b>26</b></p>	<p><b>ACCESSORIES KIT</b></p>  <p><b>27</b></p>		

		<p>All information contained is without obligation. KTM-Sportmotorcycle AG particularly reserves the right to modify any equipment, technical specifications, prices, colors, shapes, materials, services, service work, constructions, equipment and the like so as to adapt them to local conditions or to cancel any of the above items, all without previous announcement and without giving reasons. KTM may stop manufacturing certain models without previous notice. KTM shall not be held liable for any deviations of availability and/or ability to deliver, illustrations, descriptions, printing and/or other errors. The illustrated models partly contain extra equipment, which is not applied to standard models. © by KTM-SPORTMOTORCYCLE AG, Mattighofen AUSTRIA; All rights reserved; Reprint, also in extracts, with written allowance of KTM-SPORTMOTORCYCLE AG, Mattighofen only.</p>	

# FRONT FORK DISASSEMBLED

TE 250 USA 2012

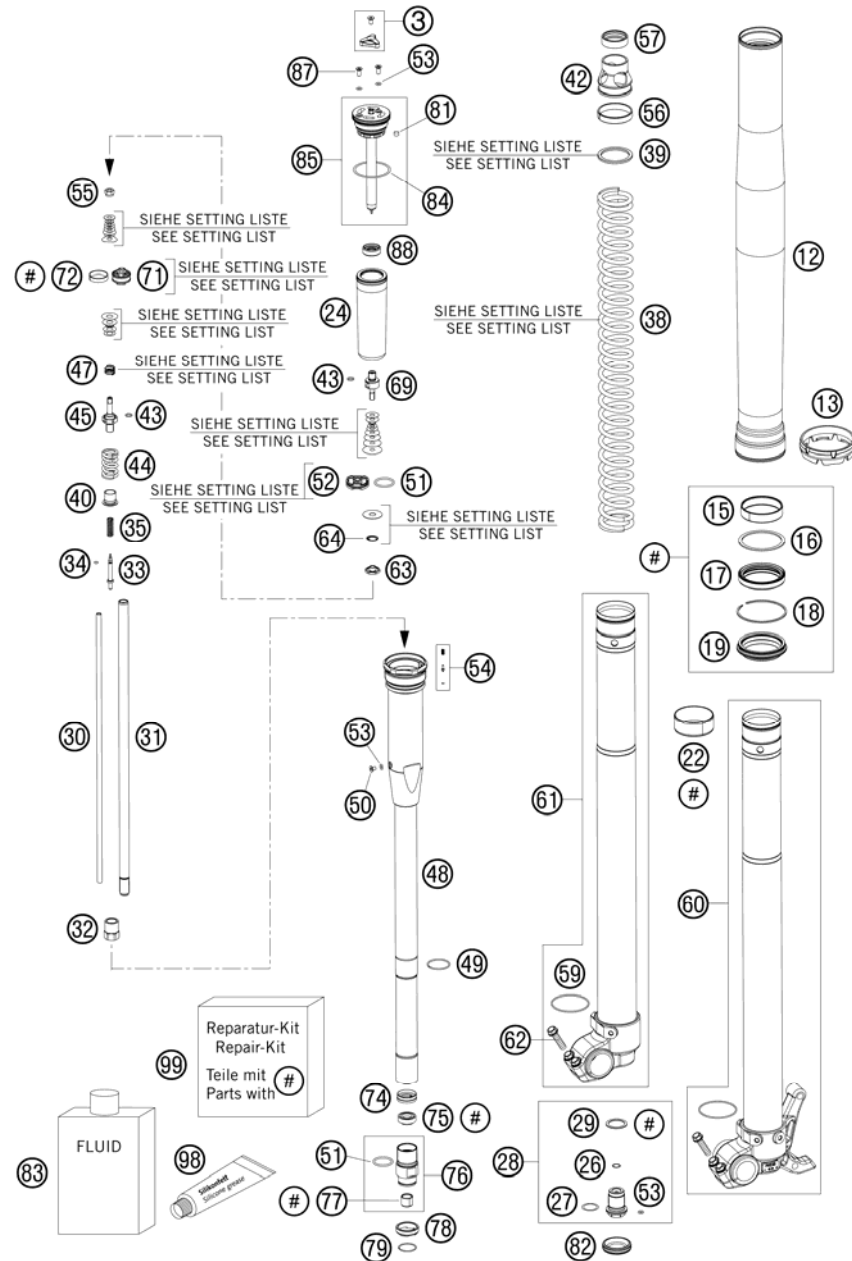

FIG	PART NUMBER	DESCRIPTION	QTY
3	48600811S	ADJUSTING KNOB + SCREW	2
12	48600736	OUTER TUBE L577 D54/60MM 2L	2
13	48600698	FORK PROTECTION RING 08	2
15	48600429	DU-BUSH D48XD52X12DDL02	2
16	48600013	SUPPORT RING 50 X 57,6 X 1,5	2
17	48600969	OIL SEAL RING D45 SKF	2
18	48600070	LOCK WASHER SB58	2
19	48600968	DUST SEAL DL D48 SKF	2
22	48600428	DU-BUSH D47XD49X20DDL02	2
24	48600281	MEMBRANE	2
26	48600301	O-RING NBR 9,5X1,5	2
27	46810811	O-RING NBR 17X2 PA	2
28	48600280S	SCREW BUSH M20X1 L=33 CPL.	2
29	48600275	COPPER WASHER 20,5X26X1	2
30	48600269	ADJUSTING TUBE L=371	2
31	48600464	PISTON ROD SXS 2005	2
32	48600459	COUNTERNUT M12X1 WS17	2
33	48600887	REBOUND NEEDLE SX	2
34	48600298	O-RING 2X1,5 NBR	2
35	48600444	REBOUND SPRING C=4N/MM	2
38	91410027S	SPRING 4,4 N/MM SET D=5,1MM	x
38	91410059S	SPRING 4,0 N/MM SET	x
38	91410060S	SPRING 4,2 N/MM SET D=5,0MM	1
39	48600456	SPACER 43X35X2,5	x
39	48600457	SPACER 43X35X5	x
39	48600458	SPACER 43X35X1,5	x
40	48600525	GUIDING BUSH REBOUND SPRING	2
42	48600520	SPRING SUPPORT	2
43	48600299	O-RING 6X1,2 NBR	4
44	48600578	SPRING REB. L=32 C=37 DI=13,9	2
45	48600576	PISTON ROD REBOUND	2
47	48600382	SHUTTLE VALVE SPRING C=0,4	2
48	48600519S3	MEMBRANE HOLDER INKL. PIN SET	2
49	48600512	LOCK WASHER D=25,5	2
50	48600542	AH SCREW M4X6	2

105230131 / C118120131

\* NEW PART

X AS REQUIRED

# FRONT FORK DISASSEMBLED

TE 250 USA 2012

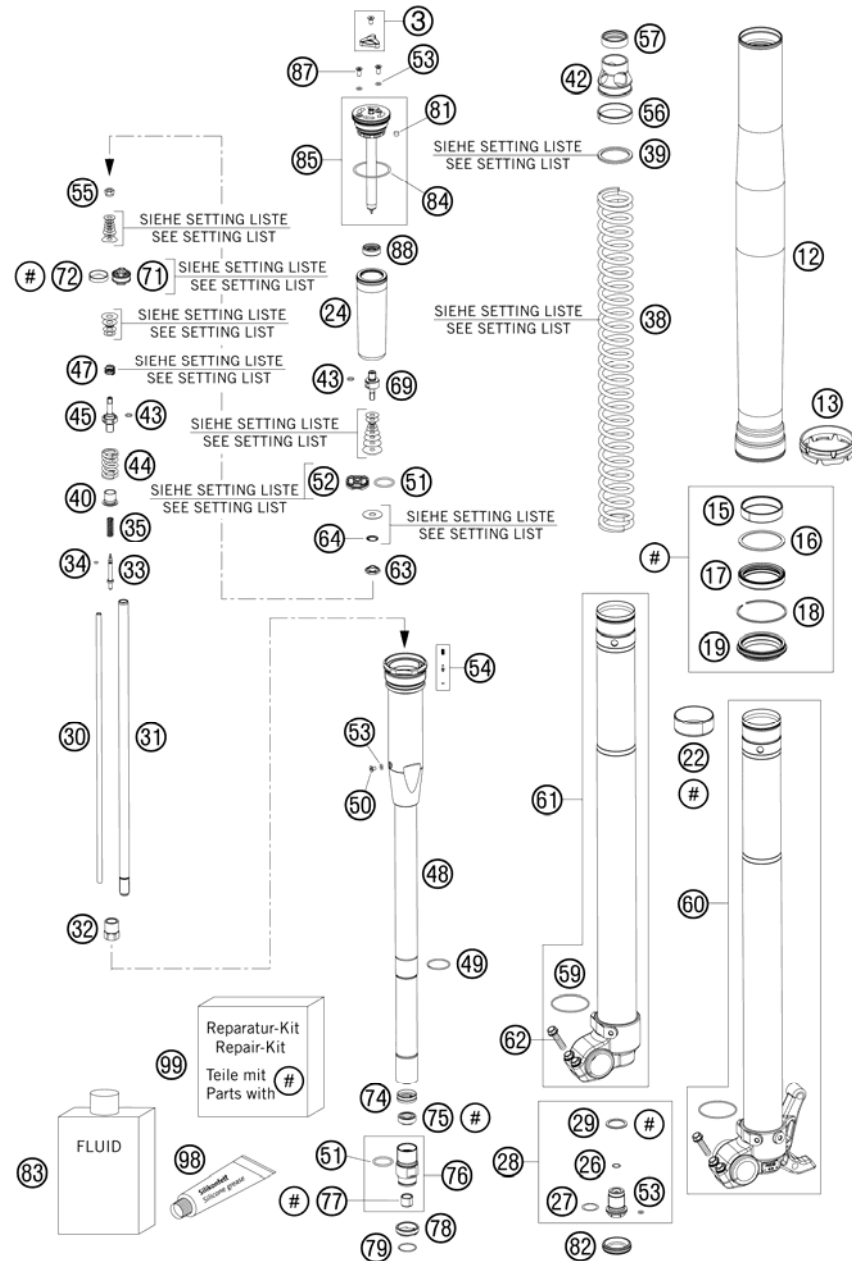

FIG	PART NUMBER	DESCRIPTION	QTY
51	46811499	O-RING NBR 21X2	4
52	48600047	PISTON COMPRESSION D=27,9	2
53	50180222	O-RING NBR 4X1,5	8
54	48600977S	PIN KIT	2
55	40540486	NUT M6X0,5 REBOUND	2
56	48600744	GUIDE RING 44 X39	2
57	48600577	RING SPRING-SUPPORT	2
59	48600113	WASHER 32X42X2,5	2
60	48600863SA	AXLE CLAMP LEFT + TUBE CPL.	1
61	48600864SA	AXLE CLAMP RIGHT + TUBE CPL.	1
62	0025080256	HH COLLAR SCREW M8X25 TX40	4
63	48600885	NUT VALVE M6X0,5 LH=1,2	2
64	48600202	SPRING CHECK VALVE D=0,7	2
69	48600509	PISTON ROD COMPRESSION	2
71	48600575	PISTON REBOUND SX 2007	2
72	48600455	PISTON RING 5X1X68	2
74	48600296	RING D=23,45X2,65	2
75	48600829	SHAFT SEAL RING 12MM	2
76	48600760S	SCREW SLEEVE M24,5X1 CPL	2
77	48600430	DU BUSH FOR PISTON ROD	2
78	48600709	CHECK VALVE STOP	2
79	48600446	LOCK WASHER D=20	2
81	15080017	SILICON CAP	2
82	48600692	RUBBER CAP D=26,4	2
83	48600765S1	FORK OIL SAE5 5L 2008	1
84	40140024	O-RING NBR 43X2	2
85	48600516S1	SCREW CAP CPL. L=125	2
87	48600526	SCREW M4X10	4
88	48600514	MEMBRANE SLEEVE	2
98	T511	SILICONE GREASE F. DUST STRI	1
99	R14019	REPAIR KIT SEALS MXMA CC 2011	1

105230131 / C118120131

\* NEW PART

X AS REQUIRED

# FRONT FORK, TRIPLE CLAMP

TE 250 USA 2012

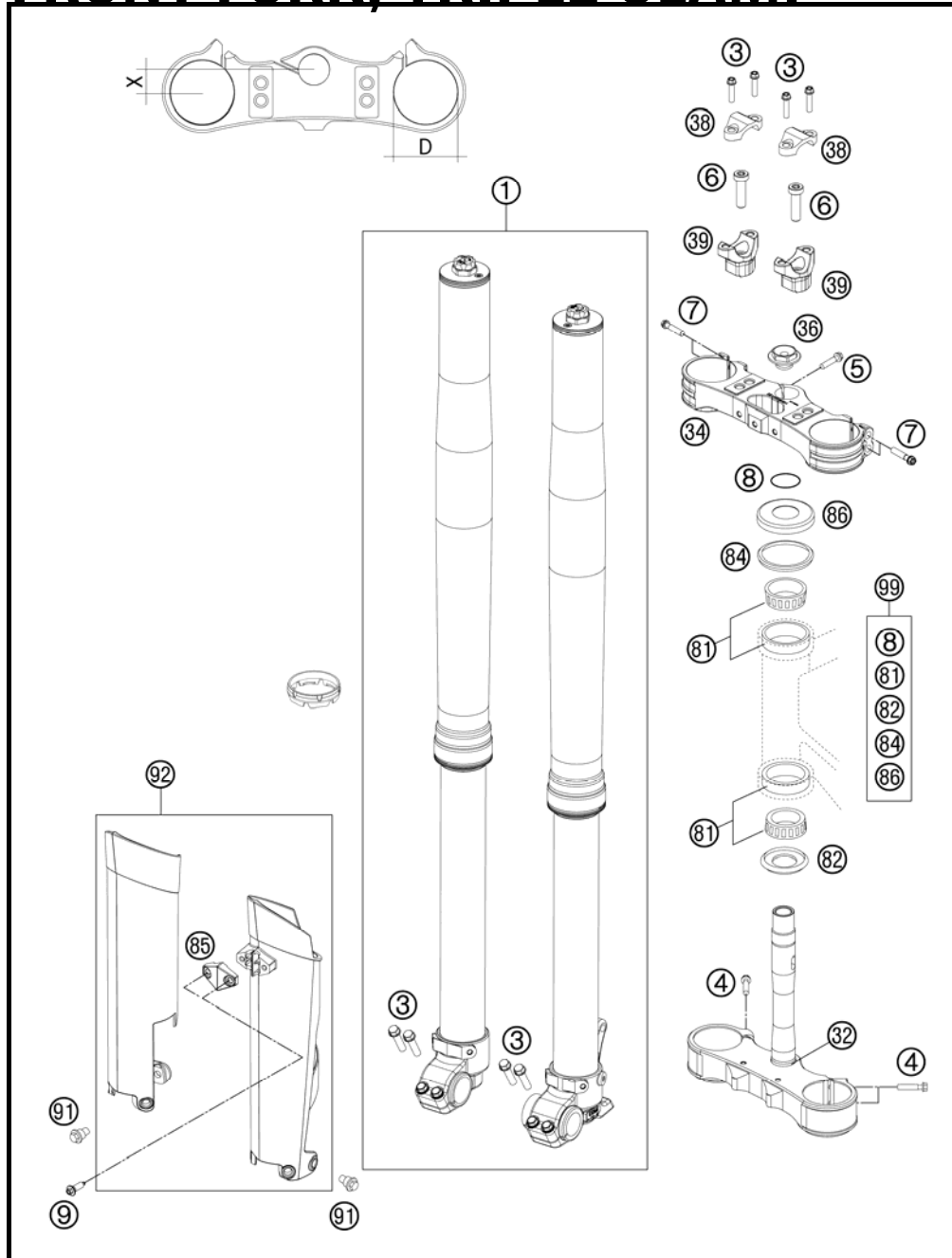

FIG	PART NUMBER	DESCRIPTION	QTY
1	14457K0401	FORK HUSABERG TE 2011	1
3	0025080256	HH COLLAR SCREW M8X25 TX40	8
4	0025080356	HH COLLAR SCREW M8X35 TX40	4
5	0025080256S	HH COLLAR SCREW M8X25 TX40	1
6	0032100356S	AH-COLLAR SCREW M10X35 ISA45	2
7	0025080406	HH COLLAR SCREW M8X40 TX40	4
8	0770025035	O-RING 25X3,55 NBR70 05	1
9	0017060204	EJOT PT SCREW K60X20 ALU WS=6	2
32	7800103212230	BOT. TRIPLE CLAMP CPL. 22MM	1
34	7720103402230	TOP TRIPLE CLAMP X=22MM BLACK	1
36	54801036000	STEER.HEAD SCREW M20X1,5 WS=27	1
38	77201038000	HANDLEBAR CLAMP 28MM	2
39	59401039032	HANDLEB.SUPP. D=28MM H=32MM 05	x
39	59401039037	HANDLEB.SUPP. D=28MM H=37MM 05	2
39	59401039042	HANDLEB.SUPP. D=28MM H=42MM 05	x
81	54201081100	TAPERED ROLLER BEARING CPL. 06	2
82	54601084100	O-RING SUPPORT W. SEALING LIP	1
84	54601184000	STEERING HEAD GASKET TOP	1
85	7800108500068	CLAMP FOR SPEED CABLE D=6MM	1
86	78101086000	STEERING HEAD COVER	1
91	59001092050	SPECIAL SCREW M6X12,5 WS=8	6
92	7800109410068	FORK PROTECTION L/S+R/S BLUE	1
99	00050000930	STEERING HEAD REP. KIT	x

125510110 / C125510111

\* NEW PART

X AS REQUIRED



# HANDLEBAR, CONTROLS

TE 250 USA 2012

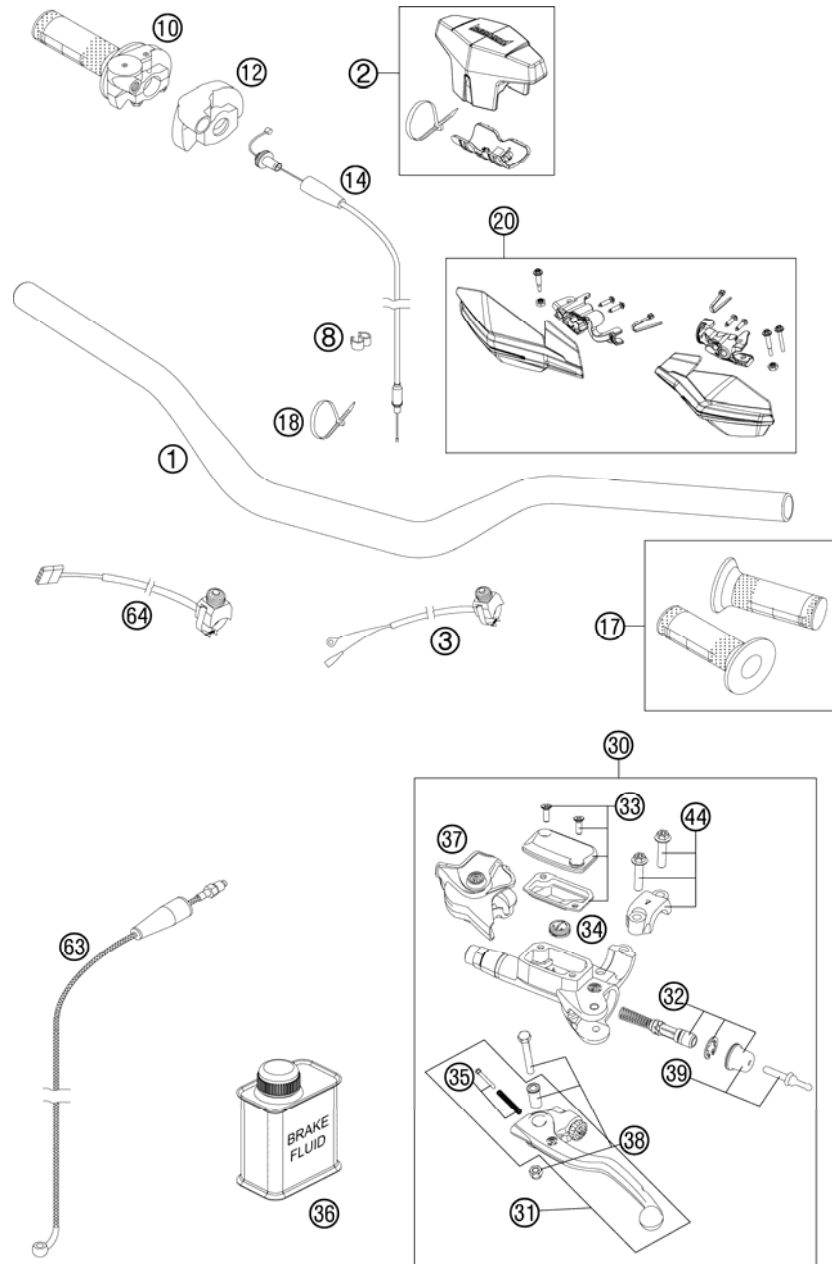

FIG	PART NUMBER	DESCRIPTION	QTY
1	5480200130017	HANDLEBAR NEKEN D=28MM EXC 07	1
2	81202002144	BAR PAD CPL.	1
3	50311089200	SHORT CIRCUIT BUTTON 02	1
8	60111094000	CLAMP 5/7 MM 06	2
10	81202510000	THROTTLE GRIP CPL.	1
12	50302020000	PROTECTION COVER '97	1
14	51502091000	THROTTLE C. 2STROKE DOM./KEIH.	1
17	81202021000	GRIP SET	1
18	44011076200	CABLE TIE 200/3,6MM BLACK	1
20	7810297900028	HANDGUARDS CPL.LE+RI WHITE 12	1
30	54802030044	MASTER CYLINDER CPL. 06	1
31	54802031000	CLUTCH LEVER CPL. BREMBO 06	1
32	54802032000	REP. KIT PISTON 06	1
33	54802003000	COVER HYD. CLUTCH CPL.	1
34	54802051000	VALVE	1
35	54802052000	BOLT KPL.	1
36	00062030000	BRAKE FLUID DOT5.1 0,25L	1
37	54802037000	PROTECTION CAP 06	1
38	54802038100	LEVER SCREW CPL. 06	1
39	54802046000	PUSH ROD CPL.	1
44	54802005100	CLAMP CPL. 06	1
63	54832063000	CLUTCH PIPE 06	1
64	59411074000	STARTER CONTROL 04	1

125510212 / C125510212

\* NEW PART

X AS REQUIRED

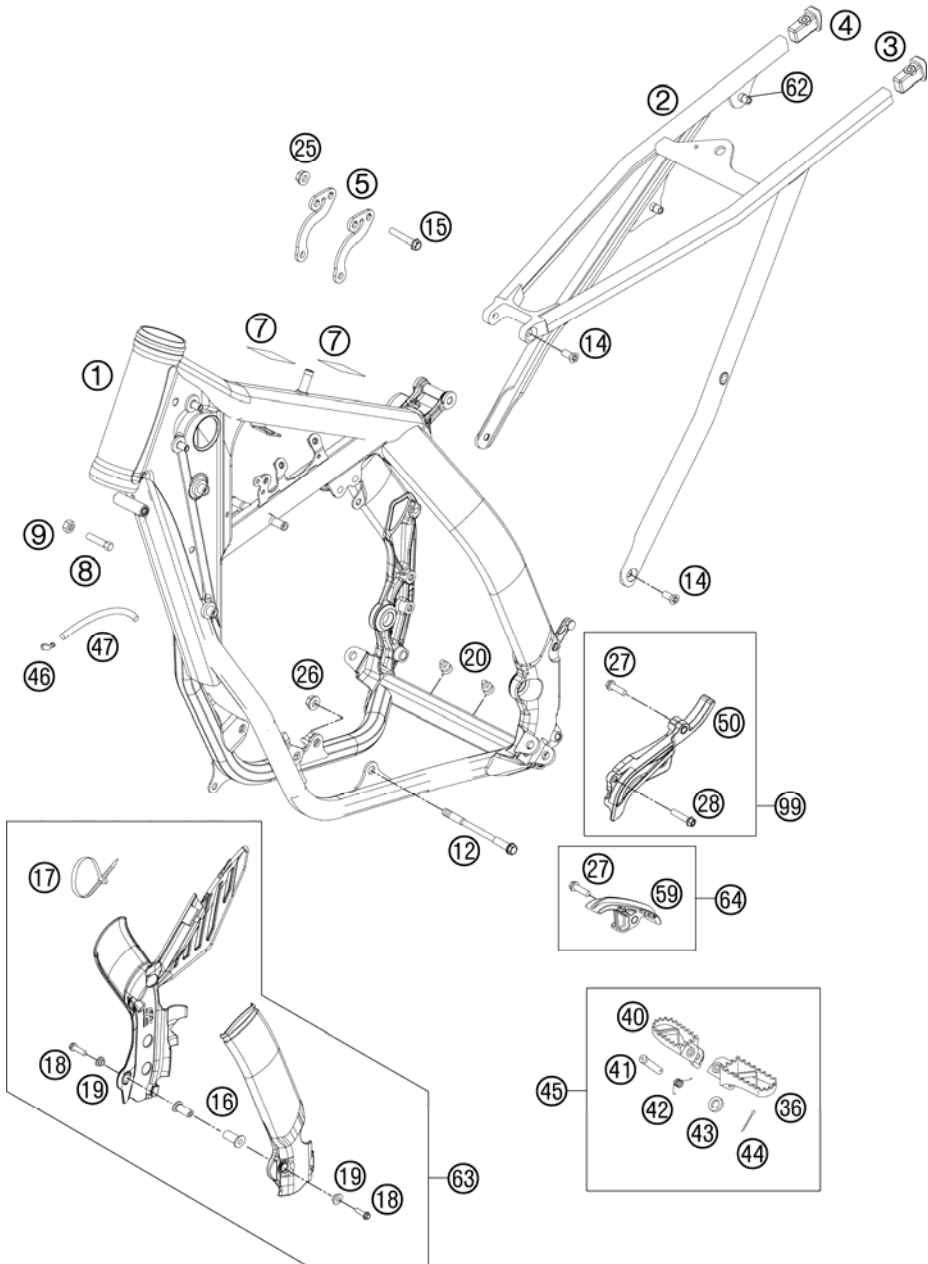

FIG	PART NUMBER	DESCRIPTION	QTY
1	54803401100DA	FRAME 2507300 "CB08" YELLOW	1
2	77303002000	SUB FRAME SX "Q7" 07	1
3	78003002010	SUB FRAME APPLICATION LEFT 08	1
4	78003002020	SUB FRAME APPLICATION RIGHT 08	1
5	54803413000	REINFORCING B. 250 SX 07	2
7	50307012000	ADH. FOIL TRANSP. 80X80 MM 04	2
8	59001037000	SPECIAL SCREW M8X26 WS=10	2
9	0934080003	HEXAGON NUT DIN0934-M 8	2
12	54603013000	ENGINE BRAC.SCR. M10X105 WS=13	2
14	0019080206S	FLAT HEAD SCREW M. ISA45 M8X20	4
15	56530079000	HH COLLAR SCREW M 8X44 WS13	3
16	54803092050	BLIND PLUG-IN NUT M5 WN 22A 03	2
17	44011076305	CABLE TIE 300/4,8MM BLACK	3
18	0738050250	COU.SUNK SCR. AH ISO7380 M5X25	2
19	54803092060	BUSH F. FRAME PROTECTION 03	2
20	54403135000	PLASTIC CAP SFL10	2
25	54310086200	SELF LOCKING NUT M8 10.9	3
26	54310086100	SELF LOCKING NUT M10 CU WS=14	2
27	0025080306	HH COLLAR SCREW M8X30 TX40	2
28	0025060306	HH COLLAR SCREW M6X30 TX30	1
36	78003040050	FOOTREST L/S 08	1
40	78003041050	FOOTREST R/S 08	1
41	54803044000	BOLT FOR FOOT PED 03	2
42	54603041000	FOOTREST SPRING L/S & R/S	2
43	0125100003	WASHER DIN0125-A10,5	2
44	0094032253	PIN DIN0094-3,2X25 STEEL	2
45	78003040033	FOOTREST L/S + R/S CPL. 09	1
46	50303089000	ANGLE PIECE '97	1
47	55007016001	PVC-HOSE 7X10 PER METER	x
50	54803096000	SPROCKET COVER 250 SX 07	1
59	77303053000	CHAIN SLIDING PIECE BELOW 07	1
62	77303139000	BLIND RIVET NUT EM6-60LF/HX	4
63	77303094100	PLASTIC FRAME PROTECTION SET	1
64	77303053010	CHAIN SLIDING KIT BELOW CPL07	1
99	54803096010	SPROCKET COVER KIT	1

125510310 / C125510311

\* NEW PART

X AS REQUIRED

# SIDE / CENTER STAND

TE 250 USA 2012

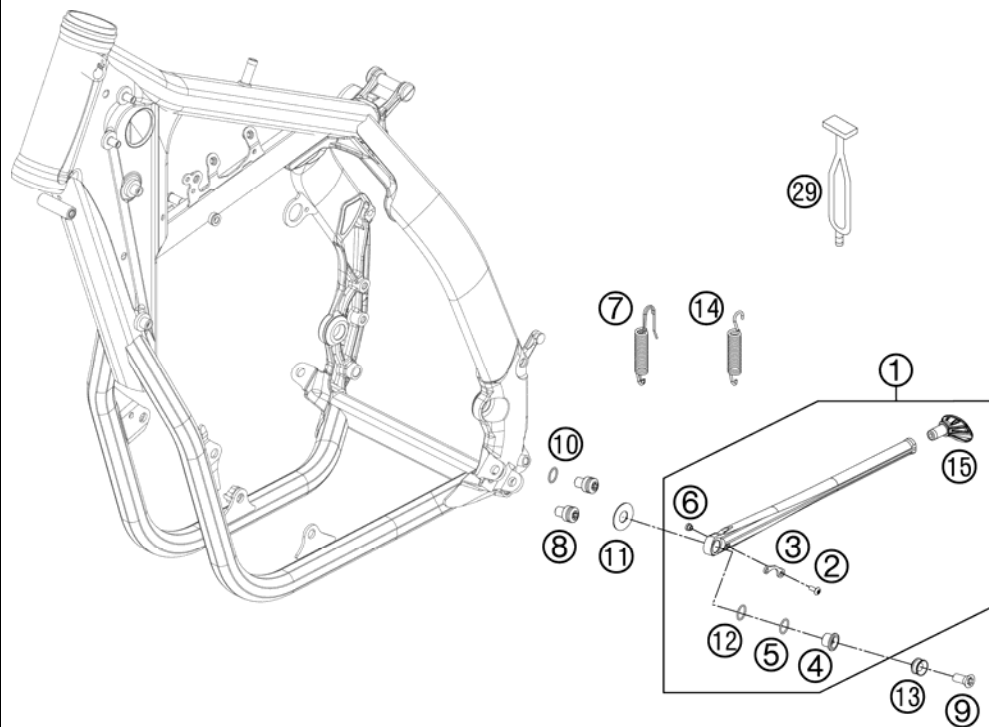

FIG	PART NUMBER	DESCRIPTION	QTY
1	78003023044	SIDE STAND CPL. 08	1
2	58605083014	SCREW M5X14 TORX 25 07	1
3	78003023090	SPRING BRACKET F. SIDE ST. 08	1
4	78003023080	SIDE STAND BUSHING EXC USA 08	1
5	0770180020	O-RING 18,00X2,00 NBR 70	1
6	78003023070	SPACER BUSH. SPRING BRACKET	1
7	81203024000	SIDE STAND SPRING EYE MOVEABLE	1
8	78003023182	SIDE STAND STOP SCREW M10X12	2
9	0019080266S	COUNTER-SUNK SCREW ISA45 M8X26	1
10	0770120020	O-RING 12,00X2,00 NBR 70	1
11	78003023083	WASHER F. SIDE STAND 12,2X29,5	1
12	0770125015	O-RING 12,5X1,5 NBR	1
13	78003023081	SIDE STAND BUSHING EXC-EU 08	1
14	78003024100	SIDE STAND SPRING 08	1
		ONLY FOR USA	
15	78003023055	STAND BASE	1
29	50303018000	RUBBER L=145MM	1

125510360 / C125510360

\* NEW PART

X AS REQUIRED

# SHOCK ABSORBER

TE 250 USA 2012

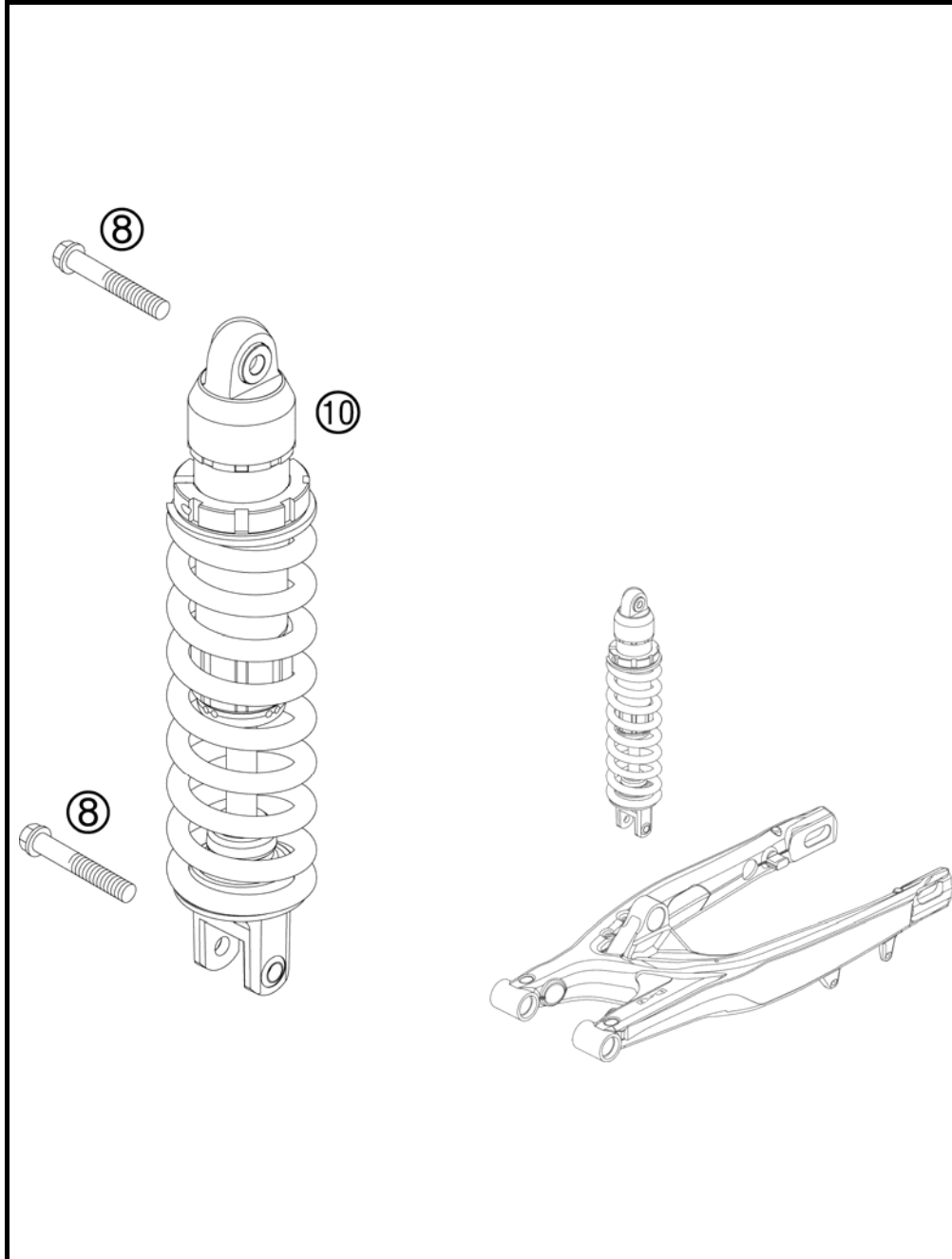

FIG	PART NUMBER	DESCRIPTION	QTY
8	0025120506S	HH COLLAR SCREW M12X50 TX45	2
10	12457K0401	MONOSHOCK HUSABERG TE 2011	1

085030410 / C118120411

\* NEW PART

X AS REQUIRED

# SHOCK ABSORBER DISASSEMBLED

TE 250 USA 2012

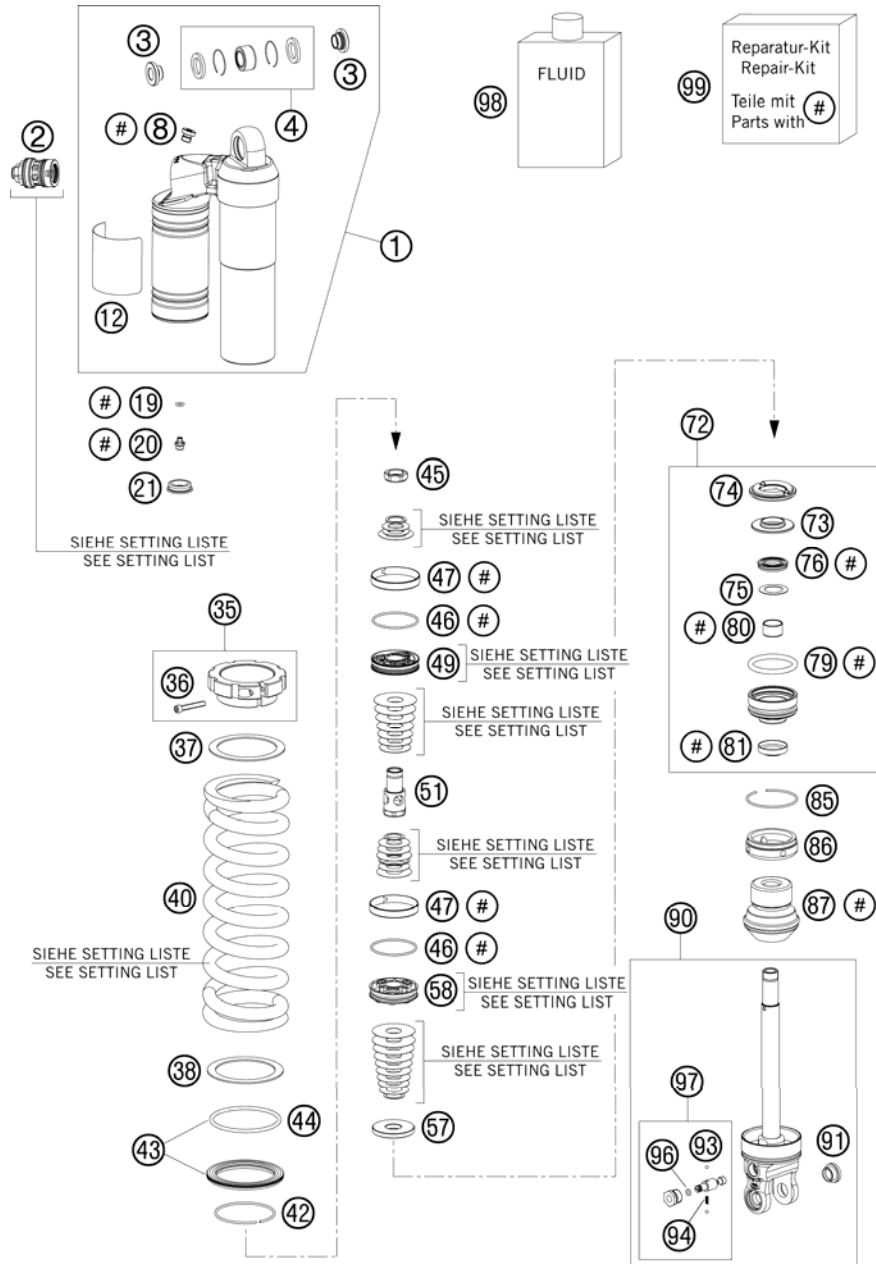

FIG	PART NUMBER	DESCRIPTION	QTY
1	50180733SA	TOP PART CPL. M57,5X1 H30,5 10	1
2	50180213S10	DCC-COMPR.DAMP.CONTROL CPL. 07	1
3	46180007	ADAPTOR BUSH KGW 12X24	2
4	R12012	REP. KIT BEAR./SEAL UP. 07	1
8	50180095	BLEED PLUG R 1/8	1
12	52000085	WP CAUTION (PDS KTM)	1
19	46810893	O-RING NBR 5,28X1,78	1
20	36120151	SCREW PLUG M5X6	1
21	46811208	RUBBER CAP "DO NOT OPEN"	1
35	50180520S	SPRING RETAINER M57,5X1 +SCREW	1
36	50180327	AH SCREW M5X30 DIN912	1
37	50180818	INTERM.RING SCREW SPRING RET.	1
38	50180114	SPACER RING FOR SPRING	1
40	91210077S	SPRING 250 66 N/MM YELLOW	x
40	91210078S	SPRING 250 69 N/MM YELLOW	1
40	91210079S	SPRING 250 72N/MM(64/62)YELLOW	x
42	50180273	CIRCLIP 58,2X2	1
43	50180463S	SPRING RET. D=80 W. O-RING 05	1
44	50180352	O-RING VITON 66,27X3,53	1
45	50180627	PISTON ROD NUT M20X1	1
46	50180099	O-RING VITON 44,17X1,78	2
47	50180135	PISTON RING 50-8	2
49	50180675	PISTON D=20	1
51	50180764	TAP D20 M20X1 L45,3	09 1
57	50180970	REBOUND DISC D43	1
58	50180197	PISTON 6+6X7/4,5	1
72	50180603S	ADAPTOR CPL. D=50 H=28	08 1
73	50180113	STEEL DISC 18X,5X43,7X6	1
74	50180107	REBOUND RUBBER	1
75	50180604	SHIM D29,75 X D19 X T0,4	08 1
76	50180605S	SEAL D18X30X5	08 1
79	50180103	O-RING 41X5	1
80	46180119	DU-BUSH 18X20X12	1
81	50180606	DUST SEAL 1828	08 1
85	50180126	CIRCLIP 53X1,75	1

105230430 / C118120430

\* NEW PART

X AS REQUIRED

# SHOCK ABSORBER DISASSEMBLED

TE 250 USA 2012

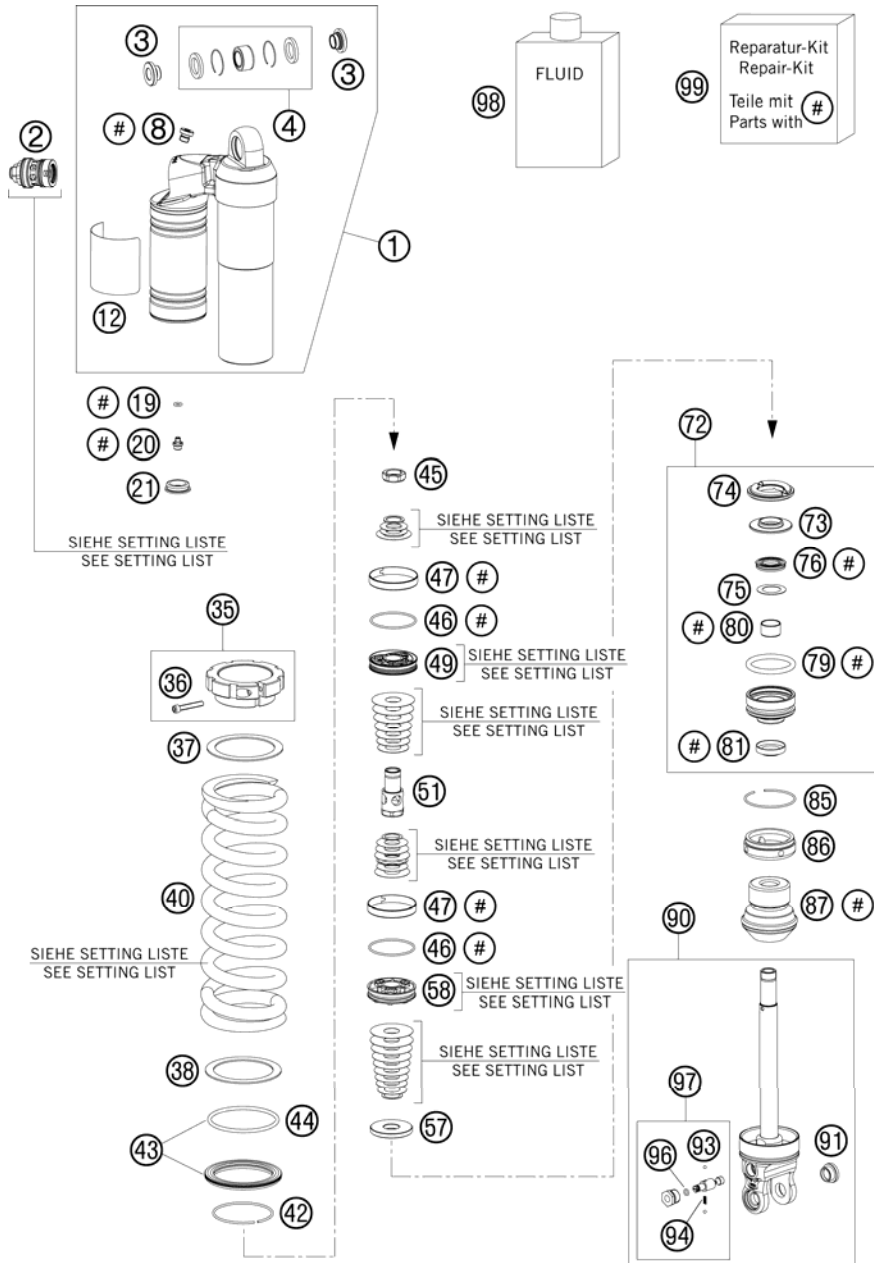

FIG	PART NUMBER	DESCRIPTION	QTY
86	50180626	RESERVOIR CAP D=50 H=10 09	1
87	50180600	BUMP RUBBER D58 D17 H59 2008	1
90	50180512SA2	SHOCK ABS. LOWER PART CPL. 10	1
91	50180105	THREADED BUSH M12 PDS	1
93	40540603	STEEL BALL D=3MM	2
94	48600028	SPRING D=2,9 L=7,9	1
96	50180222	O-RING NBR 4X1,5	1
97	50180434S	ADJUSTING SCREW REBOUND TRAVEL	1
98	50180751S1	SHOCK ABSORBER FLUID 5 LT	1
99	R12015	REPAIR KIT 5018 PDS 08	1

105230430 / C118120430

\* NEW PART

X AS REQUIRED

# SWING ARM

TE 250 USA 2012

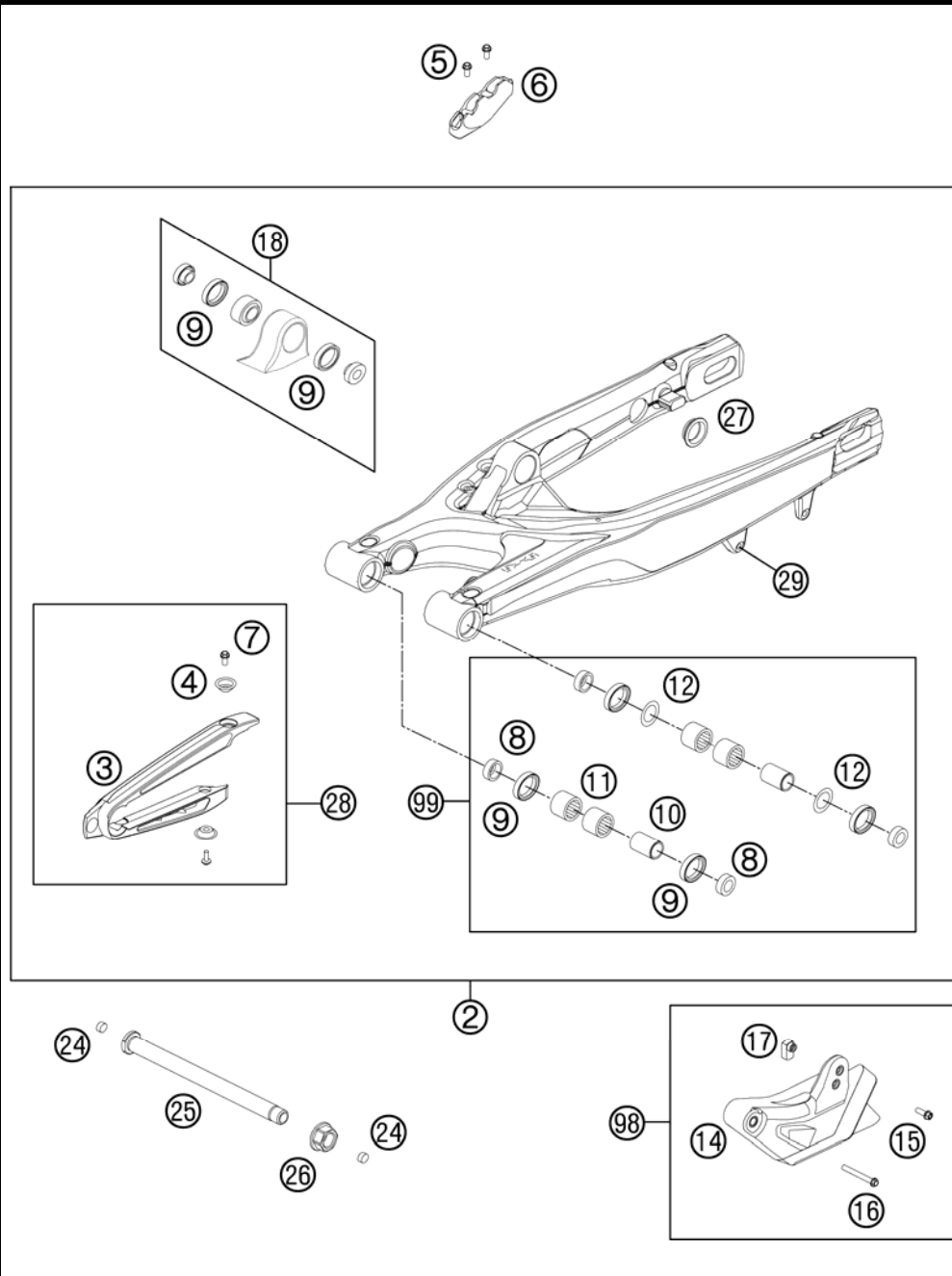

FIG	PART NUMBER	DESCRIPTION	QTY
2	77304030344	SWING ARM CPL. 2011	1
3	77304066000	CHAIN SLIDING PROTECTION	1
4	77304066050	BUSHING F. CHAIN SLIDING PR.07	2
5	0009050106	EJOT SPIRAL SCREW SF M5X10-K	2
6	77313047000	BRAKE HOSE GUIDE LOWER 07	1
7	59009062013	SPECIAL SCREW M6X13 WS=8 10.9	2
8	54804034000	BUCKET F. SHAFT SEAL RING 03	4
9	0760253270	SHAFT SEAL RING 25X32X7	6
10	54804032000	BUSHING SLEEVE F. SWING ARM 03	2
11	58033097000	NEEDLE BEARING HK 2216	4
12	54603036000	STOP DISK 22,2X31,7X1	2
14	78004070100	CHAIN GUIDE CPL.	1
15	59009062019	SPECIAL SCREW M6X19 WS=8 10.9	1
16	0025060456	HH COLLAR SCREW M6X45 TX30	1
17	77304070030	INSERTION NUT F. CHAIN GUIDE	1
18	50304090144	PIVOT BEARING+BUSH. PDS '11	1
24	55009086000	PLUG SFL13	2
25	77304037000	SWINGARM BOLT M16X1,5 07	1
26	54804038000	SELF LOCK.NUT M16X1,5 WS=19 03	1
27	58404041100	CLOSING COVER ROUND 03	4
28	77304066010	CHAIN GUARD CPL. 07-11	1
29	54603055051	PRESS IN NUT M6 STEEL ZINC	1
98	77304070310	CHAIN GUIDE KIT REAR 08-11	1
99	54804230210	SWINGARM REPAIR KIT 05-12	x

115230490 / C125510490

\* NEW PART

X AS REQUIRED

# EXHAUST SYSTEM

TE 250 USA 2012

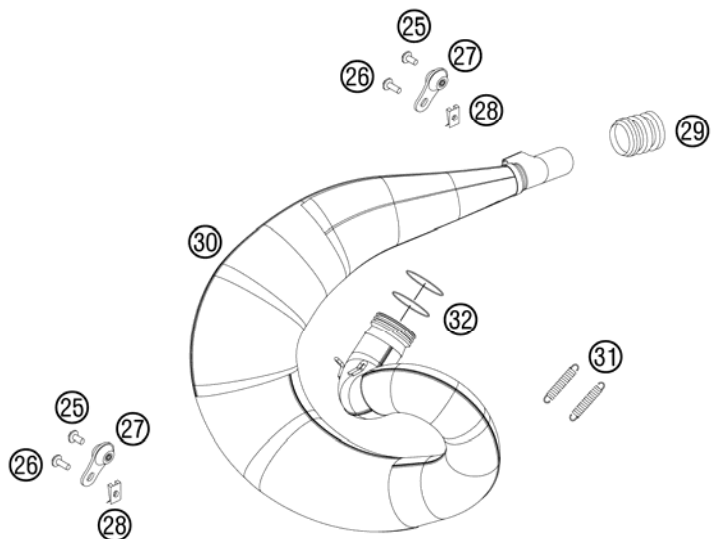
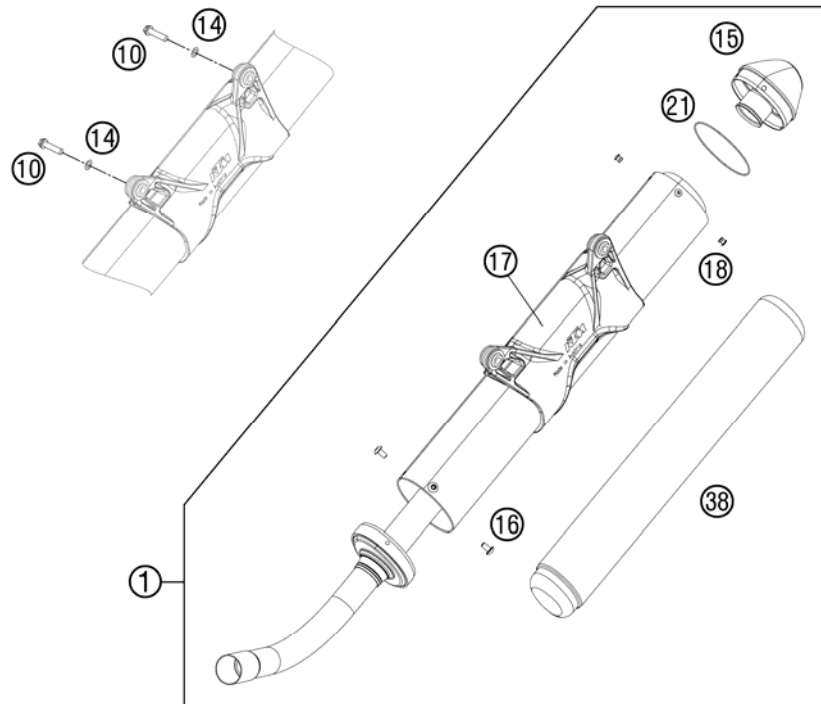

FIG	PART NUMBER	DESCRIPTION	QTY
1	54805083200	MAIN SILENCER 250-300 EXC	1
10	0025060306	HH COLLAR SCREW M6X30 TX30	2
14	0137060003	SPRING WASHER DIN0137-B 6	2
15	54805083260	ENDCAP CPL.	1
16	58605083010	SCREW TORX M5X10 05	4
17	54805183085	SILENCER HOUS. CPL. W. HANGING	1
18	0011480800	DUMMY RIVET 4,8X 8 NIRO	4
21	0770740015	O-RING 74,00X1,50 FKM 75SH	1
25	0024060106	HH COLLAR SCREW M6X10 TX30	2
26	0024060156	HH COLLAR SCREW M6X15 TX30	2
27	50305012000	SWINGELEMEN FOR EXHAUST PIPE	2
28	54603048100	RANGE CHANGE METAL NUT M6	2
29	50205057000	SILICON SLEEVE D=29/31MM	1
30	54805107000	EXHAUST MANIFOLD	1
31	50305016000	TEN.SPRING L=62MM EY.MOVEABLE	2
32	0770440030	O-RING 44,00X3,00 VITON	2
38	54805078315	ROCKWOOL 315G	1

125510510 / C125510510

\* NEW PART

X AS REQUIRED



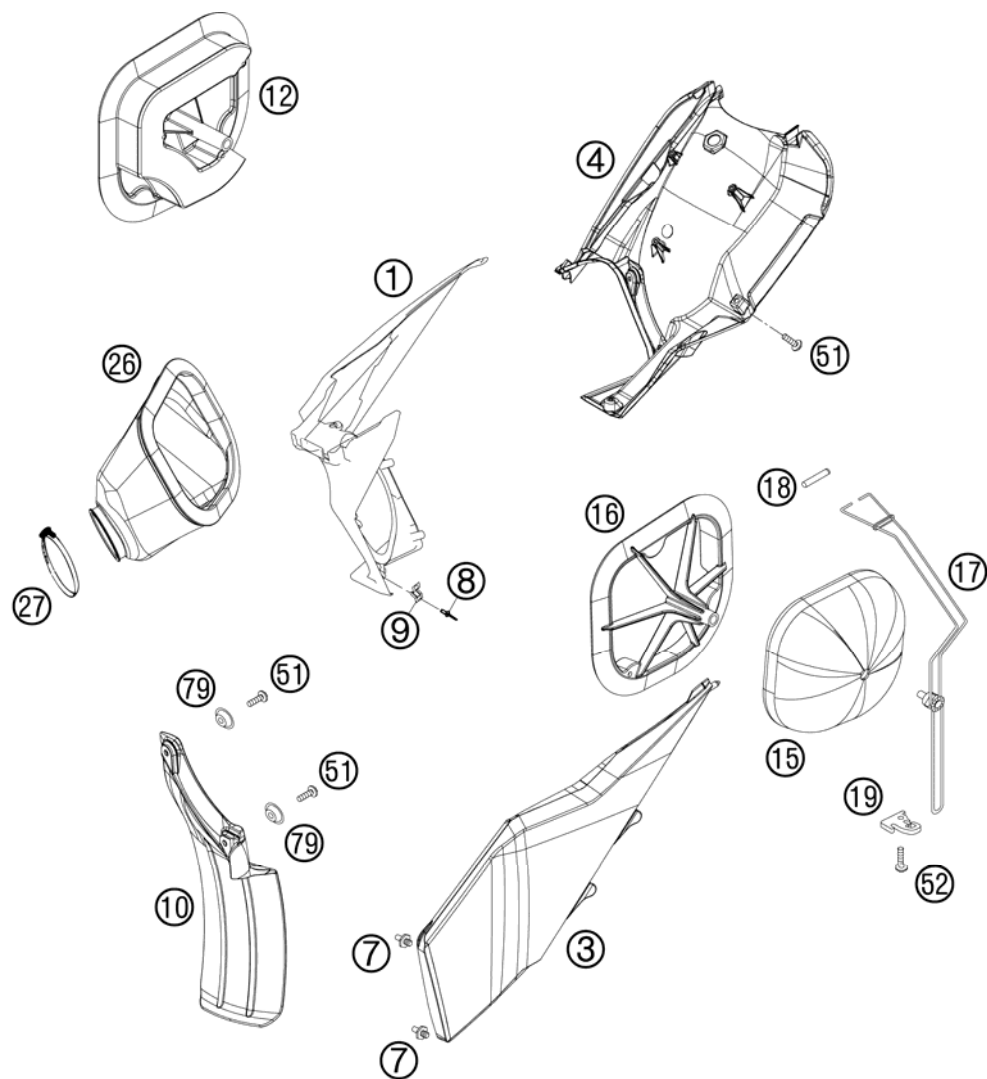

FIG	PART NUMBER	DESCRIPTION	QTY
1	7730600111030	AIR BOX PART BLACK	1
3	7730600300030	AIR BOX COVER SX BLACK 07	1
4	77306001020	REAR PART FILTER BOX 07	1
7	54806008051	QUICK RELEASE-NIPPLE 03	2
8	54806108052	BLIND RIVET 3,3X9,7 GROOVED 04	4
9	54806008050	QUICK RELEASE-SPRING HANGER	2
10	77306010000	FENDER FOR FILTER BOX	1
12	78006012000	THROTTLE CAP CPL. EXC 08	1
15	78006015000	AIR FILTER	1
16	54806416000	FILTER CARRIER 2S SX 07	1
17	77306017000	FILTER SUPPORT CPL. 07	1
18	77306018000	FILTER SUPPORT BUSH 07	1
19	77306019000	FASTEN. DEVICE FILTER S. SX 07	1
26	54806426000	CABURETOR CONNECTING 2S 07	1
27	51006027000	HOSE CLAMP 50-70MM	1
51	0017060204	EJOT PT SCREW K60X20 ALU WS=6	x
52	0017060203	EJOT PT SCREW K60X20 WS=6	1
79	77304066050	BUSHING F. CHAIN SLIDING PR.07	2

085030610 / C105480610

\* NEW PART

X AS REQUIRED

# TANK, SEAT, COVER

TE 250 USA 2012

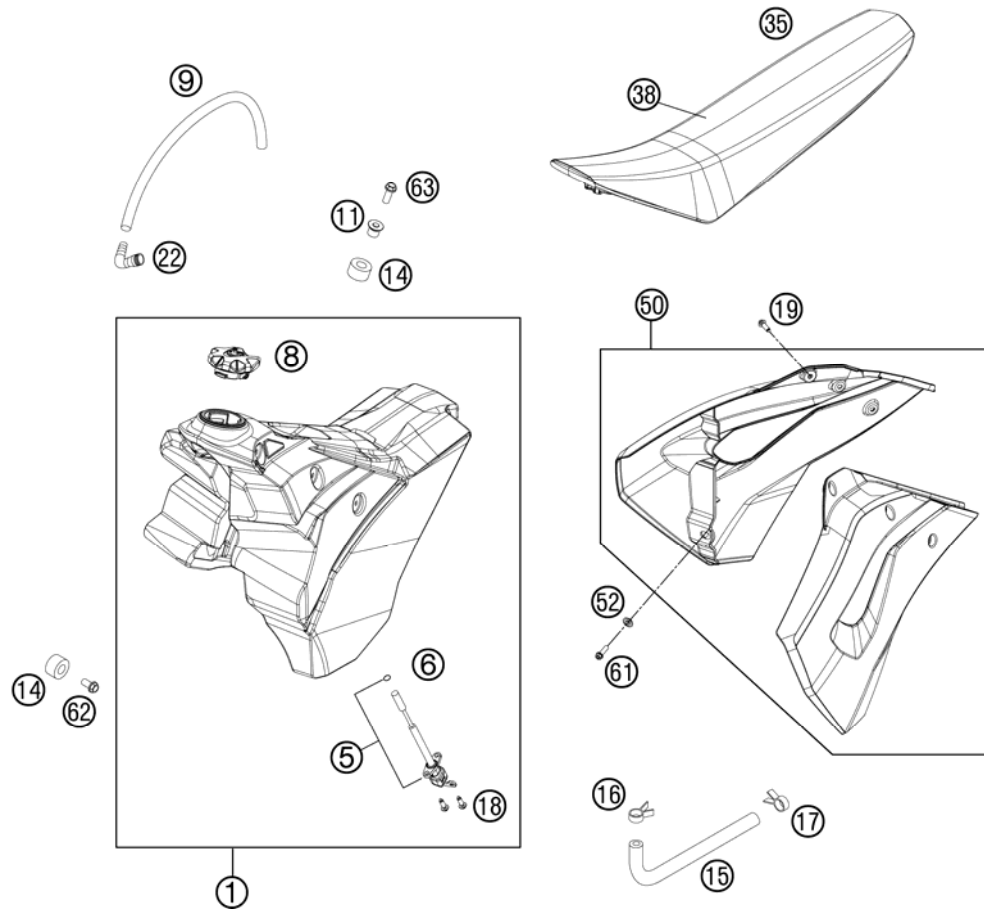

FIG	PART NUMBER	DESCRIPTION	QTY
1	8120751304499	FUEL TANK CPL. 11 LIT. TE 12	1
5	54807004000	GAS COCK ON/OFF/RES 03	1
6	0770110021	O-RING 11X2 VITON	1
8	7800700804455	TANK PLUG CPL. HUSABERG 09	1
9	78007000270	PVC-HOSE 5,6X10X270MM	1
11	77307026000	TANK BUSHING 07	1
14	50307014000	TANK ROLLER 12X26X12 '98	3
15	50307016000	FUEL PREFORMED HOSE SX 2001	1
16	58007117000	YDNAC-CLAMP 10107 10MM	1
17	58031005000	CLAMP YDNAC 10128 12MM	1
18	0017060203	EJOT PT SCREW K60X20 WS=6	2
19	0017060204	EJOT PT SCREW K60X20 ALU WS=6	6
22	51030022000	ANGLE PIECE 90 DEGREE M10X1	1
35	81207540000	SEAT TE	1
38	81207540050	SEATCOVER TE	1
50	8120805400068C	SPOILER SET BLUE 2012 WITH DECAL	1
52	50308052000	BUSH FOR SPOILER 6X11X16X5 MM	2
61	0025060206	HH COLLAR SCREW M6X20 TX30	2
62	0025060126	HH COLLAR SCREW M6X12 TX30	2
63	0024060273	COLLAR SCREW M6X27 TX	1

118120711 / C125510711

\* NEW PART

X AS REQUIRED

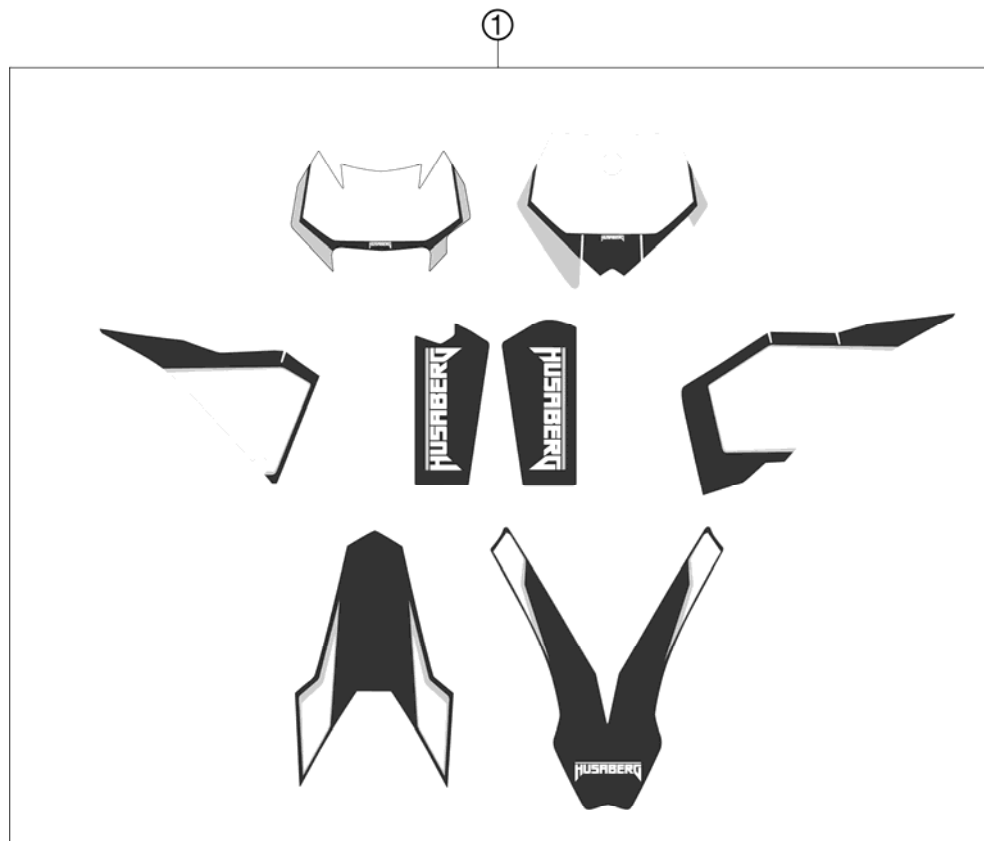
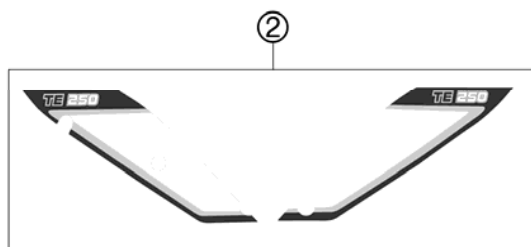

FIG	PART NUMBER	DESCRIPTION	QTY
1	81208099400	DECAL KIT HUSABERG TE 2012	1
2	81208599100	DISPLACEM. STICKER TE 250 2012	1



125480836 / C125480836

\* NEW PART

X AS REQUIRED

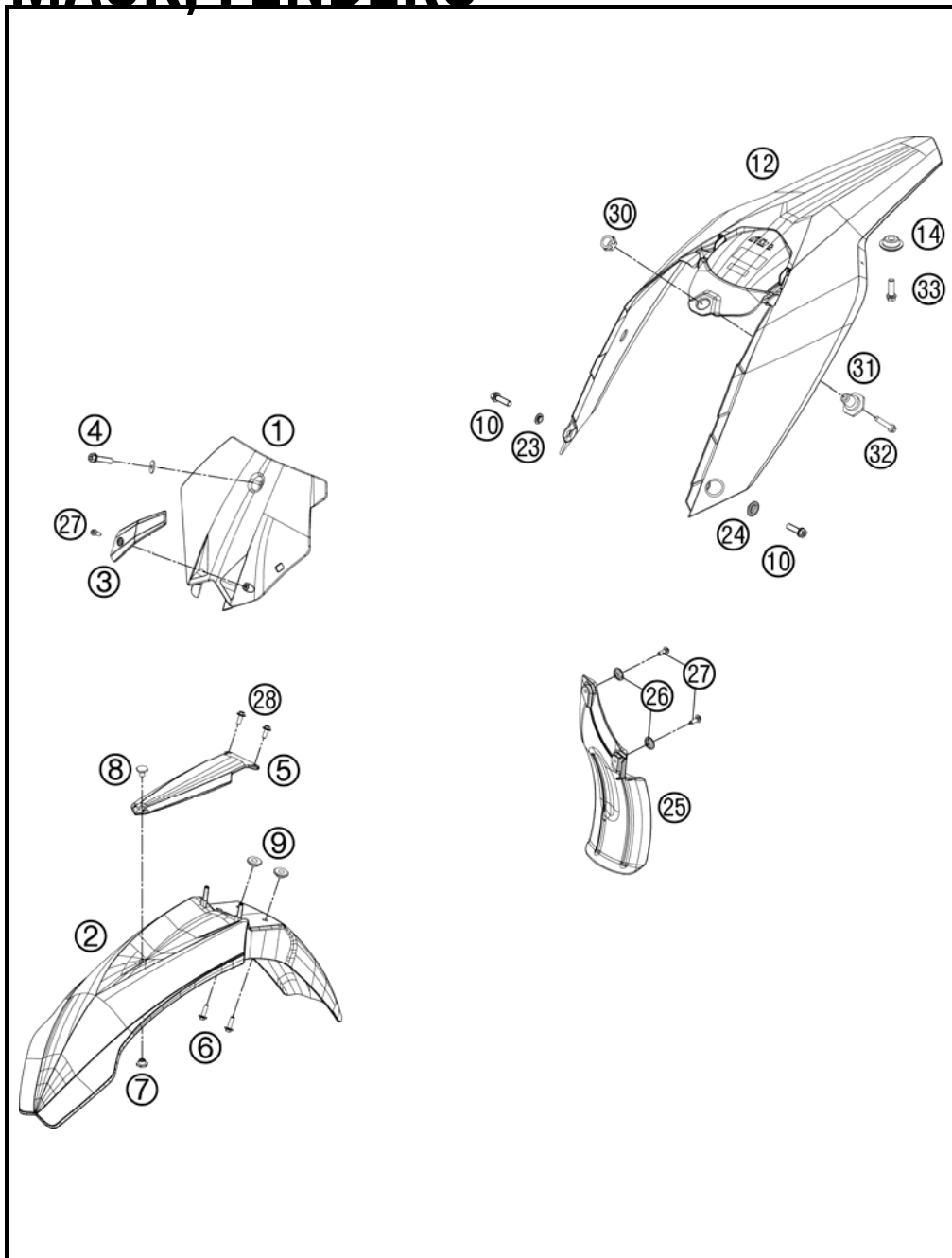

FIG	PART NUMBER	DESCRIPTION	QTY
1	5480800710030	NUMBER PLATE BLACK	1
2	8120801000068	FRONT FENDER 2009	1
3	54808019100	BRAKE HOSE GUIDE	1
4	0025060406	HH COLLAR SCREW M6X40 TX30	1
5	50308009100	FENDER BRACE BLACK '99	1
6	0024060206	HH COLLAR SCREW M6X20 TX30	4
7	50308009051	NUT FENDER BRACE M8 WS=17	1
8	50308009050	SCREW FEND.BRACE M8X9 WS=17	1
9	54808020000	SPACER BUSHING 03	4
10	0025060206	HH COLLAR SCREW M6X20 TX30	2
12	7800801300030	REAR PART EXC BLACK	1
14	77308013010	COLLAR BUSH. F.REAR FENDER 07	2
23	50308052000	BUSH FOR SPOILER 6X11X16X5 MM	1
24	77306001030	COLLAR BUSHING 4,5/12,6/23	1
25	77306010000	FENDER FOR FILTER BOX	1
26	77304066050	BUSHING F. CHAIN SLIDING PR.07	2
27	0017060204	EJOT PT SCREW K60X20 ALU WS=6	3
28	0024060136	HH COLLAR SCREW M6X13 TX30	2
30	50314057050	COLLAR NUT M12X1/WS17 H=5MM	1
31	54807048000	BUSHING FOR SEAT FASTENING 03	1
32	0025060256	HH COLLAR SCREW M6X25 TX30	1
33	0025050166	HH COLLAR SCREW M5X16 TX30	2

125510810 / C125510812

\* NEW PART

X AS REQUIRED



# REAR WHEEL

TE 250 USA 2012

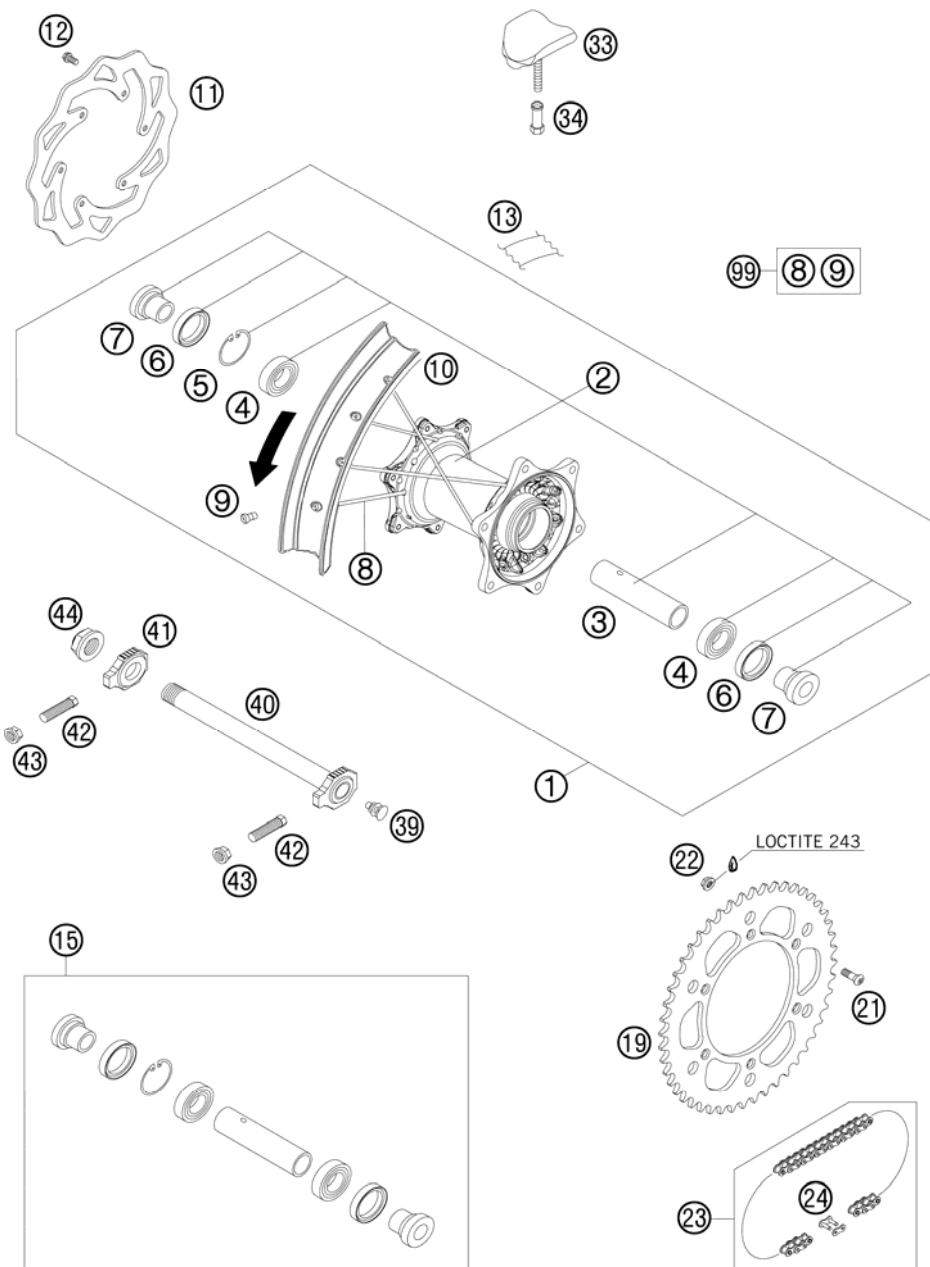

FIG	PART NUMBER	DESCRIPTION	QTY
1	8121000114468	REAR WHEEL CPL. 2,15X18" 12	1
2	78010010144	REAR WHEEL HUB CPL.	1
3	59010011000	BUSHING SPACER TUBE 121,5MM 01	1
4	0625060058	GR.BALL BEAR.6005 DDU2CG23S6NM	2
5	0472047175	CIRCLIP DIN0472-47X1,75	1
6	0760324771	SHAFT SEAL RING 32X47X7 BSL	2
7	78010016000	BUSHING FOR HUB 08	2
8	77110071193	SPOKE M4,5X193- 18" 11	36
9	77109072000	SPOKE NIPPLE M4,5 AL 11	36
10	8121007010068	RIM 2,15X18" DID AL7 BLUE	1
11	77310060000	BRAKE DISC REAR 220	1
12	59009062013	SPECIAL SCREW M6X13 WS=8 10.9	6
13	50310073200	RIM BAND 18" AND 19"	1
15	78010015000	REAR WHEEL REP. KIT	x
19	58310051038	REAR SPROCKET 38-T	x
19	58310051042	REAR SPROCKET 42-T	x
19	58310151040	REAR SPROCKET 40-T	x
19	58310151045	REAR SPROCKET 45-T	x
19	58310151048	REAR SPROCKET 48-T	x
19	58310151049	REAR SPROCKET 49-T	x
19	58310151050	REAR SPROCKET 50-T	1
19	58310151051	REAR SPROCKET 51-T	x
19	58310151052	REAR SPROCKET 52-T	x
21	0019080266S	COUNTER-SUNK SCREW ISA45 M8X26	6
22	06923080003	HEXAGON NUT DIN EN1661 M8 SW13	6
23	78010167118	CHAIN DID 118 ROLLS	1
24	78010166000	CONNECTING LINK F. 78010167118	1
33	54010100100	RIM LOCK VM3 (2.15")	1
34	77110090050	NUT FOR WHEEL HOLDER	1
39	50210086000	COVERING CAP SFL16	1
40	77310085044	WHEEL SPINDLE RE. CPL.265MM 07	1
41	50310084000	CHAIN TENSIONER R/S 2000	1
42	50304040100	SCREW M10X1,25X50 WS=10	2
43	58414030000	HH COLLAR NUT M10X1,25 WS=13	2
44	50310099000	HEXAGON NUT M20X1,5 '98	1

098121010 / C125511011

\* NEW PART

X AS REQUIRED

# WIRING HARNESS

TE 250 USA 2012

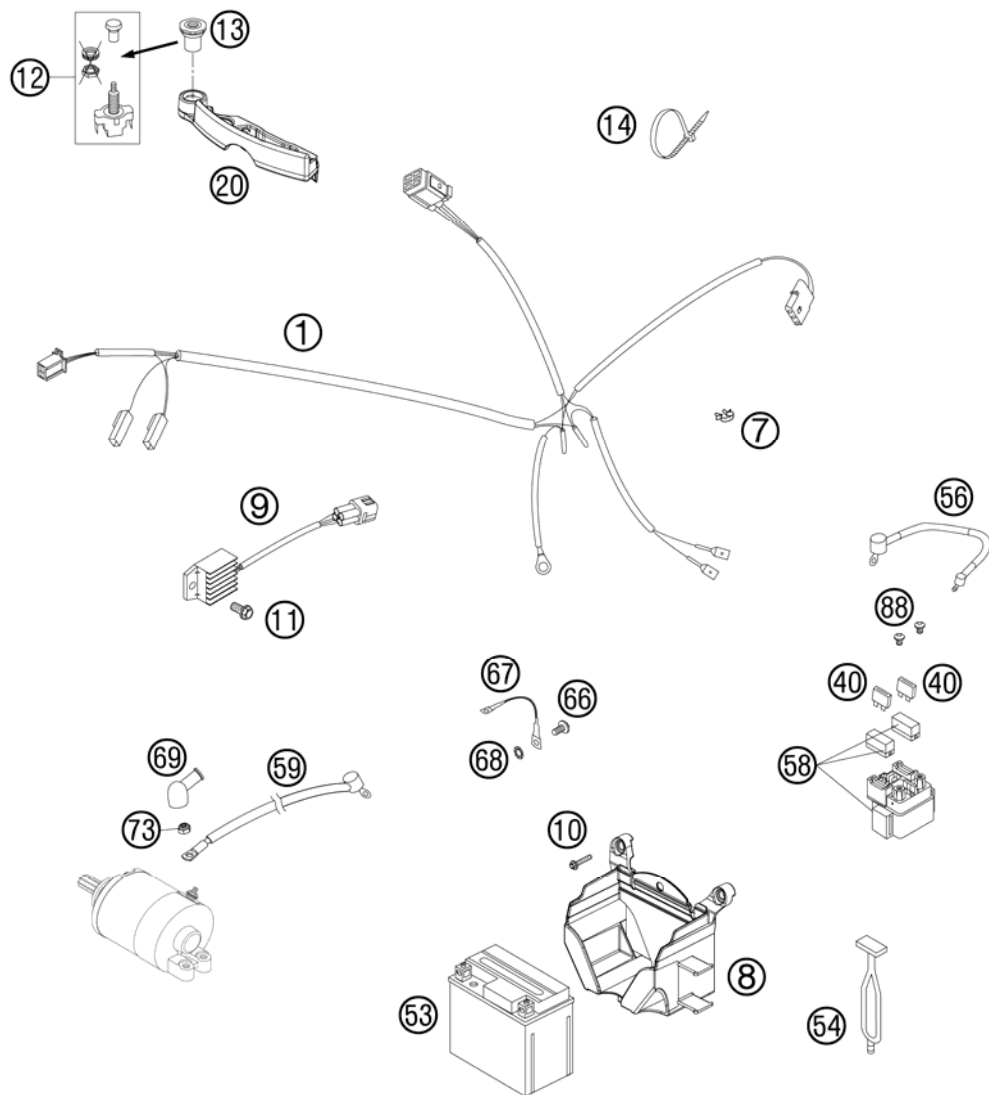

FIG	PART NUMBER	DESCRIPTION	QTY
1	59411075100	WIRING HARNESS RACING USA '05	1
7	57013072100	WIRING HOLDER 16MM	x
8	77311055000	BATTERY CASING	1
9	80011034000	VOLTAGE REGULATOR '04	1
10	0017060203	EJOT PT SCREW K60X20 WS=6	3
11	0025060126	HH COLLAR SCREW M6X12 TX30	1
12	55011599000	PULL SWITCH LOOSE	1
13	54814060050	SPEC. NUT F. PULL SWITCH WS=17	1
14	44011076200	CABLE TIE 200/3,6MM BLACK	x
14	44011076305	CABLE TIE 300/4,8MM BLACK	x
20	54814060100	SPEEDOMETER BRACKET XC-W '08	1
40	58011109110	FUSE 10 A 2000	2
53	77311053000	BATTERY 12V 3AH YTX4L-BS	1
54	50303018000	RUBBER L=145MM	2
56	58711086000	WIRING HARNESS BATTERY DUKE'99	1
58	58211058000	STARTER RELAY 12V '99	1
59	55111059000	STARTERCABLE 1100MM '07	1
66	0009050103	% SPECIAL SCREW M 5,0X10	1
67	58411097100	GROUND CABLE D=6MM L=140MM '97	1
68	58411098100	CONTACT WASHER M6 VSV-K6	1
69	58440099000	PROTECTION CAP F. STARTER ENG.	1
73	0985060003	SELF LOCK. NUT DIN0985-M 6	1
88	0902060083	AH OVAL SCREW ISO 7380 M 6X8	2

085481111 / C095481111

\* NEW PART

X AS REQUIRED

# HAND BRAKE CYLINDER

TE 250 USA 2012

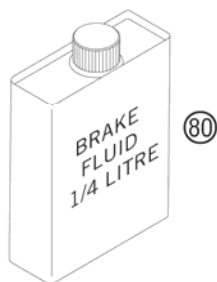
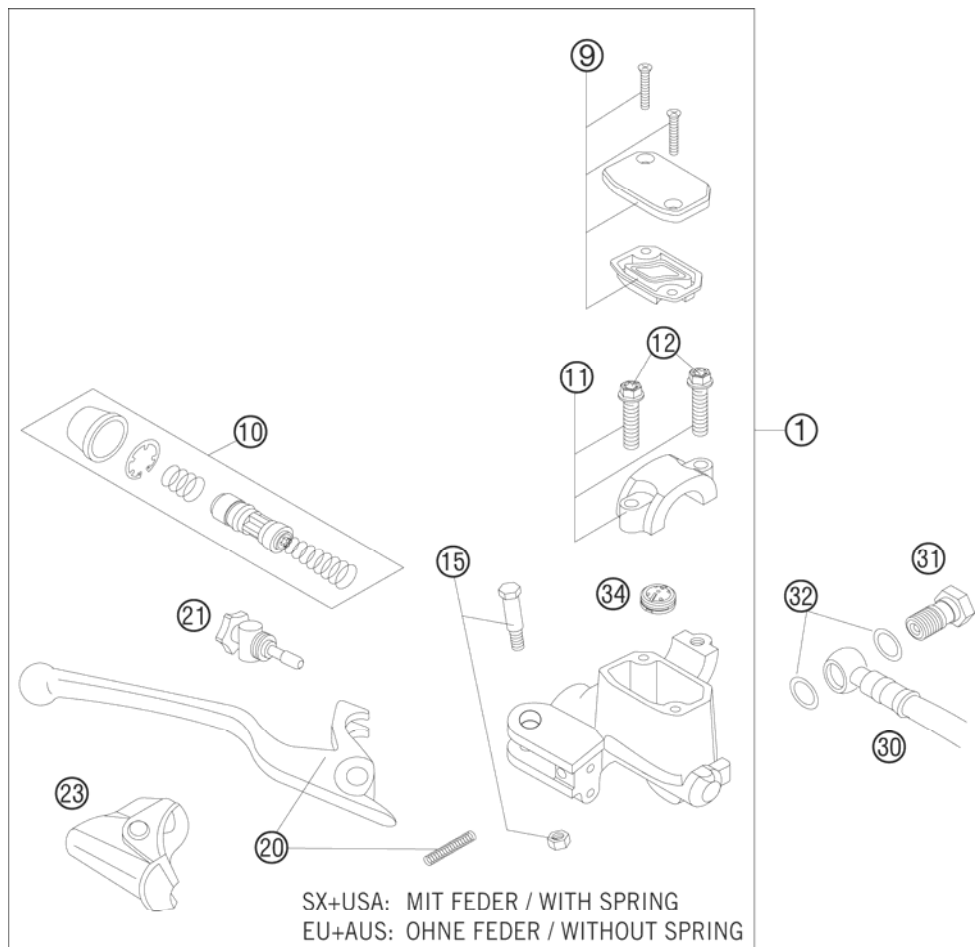

FIG	PART NUMBER	DESCRIPTION	QTY
1	77013001044	HAND BRAKE CYLINDER CPL. SX 09	1
9	50313003000	HANDBRAKE CYL.COVER CPL.NATURE	1
10	54813008300	REP.SET PISTON D=9MM 2009	1
11	50313005000	CLAMP CPL. NATURE	1
12	0025060256	HH COLLAR SCREW M6X25 TX30	2
15	50313006100	LEVER SCREW CPL. 2001	1
20	54813002200	HAND BRAKE LEVER + SPRING 2009	1
21	54813007300	ADJUSTING SCREW CPL. SX 2009	1
23	50313004000	PROTECTION CAP HAND BRAKE CYL.	1
30	59013011000	BRAKEHO. FRONT 1300MM 2000	1
31	54813020200	% BANJO SCREW 08	1
32	0603100141	COPPER GASKET DIN7603-10X14X1	2
34	54802051000	VALVE	1
80	00062030000	BRAKE FLUID DOT5.1 0,25L	1

097701310 / C098121311

\* NEW PART

X AS REQUIRED



# BRAKE CALIPER FRONT

TE 250 USA 2012

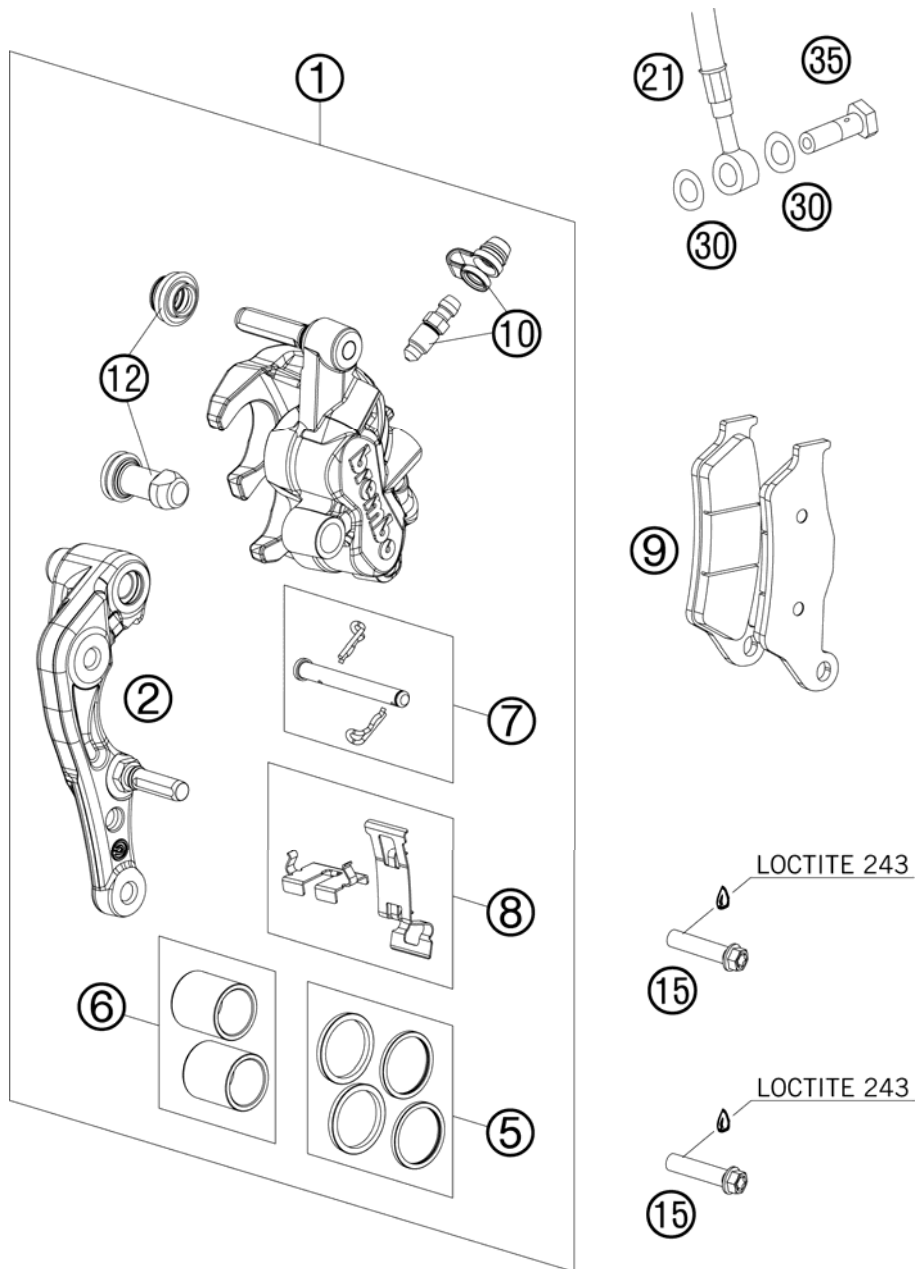

FIG	PART NUMBER	DESCRIPTION	QTY
1	7701301500101	CALIPER NAT. WITHOUT PADS	1
2	77013014000	BRAKE CALIPER SUPPORT FRONT 09	1
5	77013021000	REP. KIT SEALS 24MM	1
6	77013019000	REP. KIT PISTON 24MM	1
7	77013017000	BOLT CPL. 09	1
8	77013018000	RETAINING PLATE SET BREMBO	1
9	77013020000	BRAKE PADS TOYO B153	1
10	61013020100	BLEEDER SCREW WITH CAP	1
12	54613218000	CUP SET SHORT	1
15	0025080356S	HH COLLAR SCREW M8X35 TX40	2
21	59013011000	BRAKEHO. FRONT 1300MM 2000	1
30	0603100141	COPPER GASKET DIN7603-10X14X1	2
35	54813020200	% BANJO SCREW 08	1

097701361 / C098121361

\* NEW PART

X AS REQUIRED

# BRAKE CALIPER REAR

TE 250 USA 2012

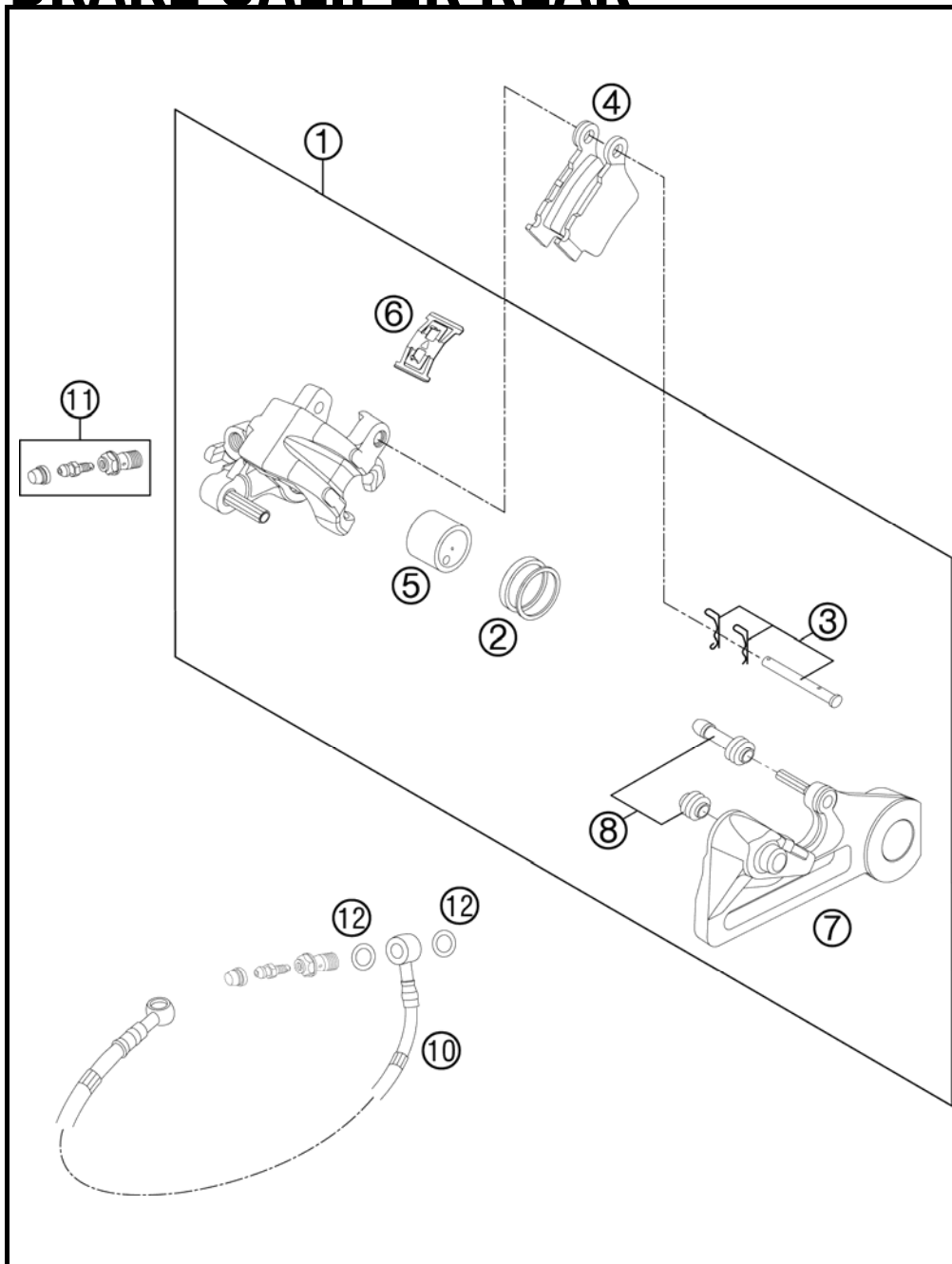

FIG	PART NUMBER	DESCRIPTION	QTY
1	54813080101	BRAKE CAL. RE. - WITHOUT PADS	1
2	50313081200	REPAIR KIT SEALING RINGS 26MM	1
3	54813082000	BOLT SET FOR BRAKE CALIPER 03	1
4	54813090300	BRAKE PAD SET REAR TOYO	1
5	54813083000	BRAKE PISTON 26MM 2003	1
6	54813018000	RETAINING SPRING SET 2003	1
7	54813075000	BRAKE CALIPER SUPPORT REAR	1
8	54613218000	CUP SET SHORT	1
10	54813070000	BRAKE HOSE REAR 655MM 03	1
11	62513020000	BLEEDER SCREW CPL. 05	1
12	0603100141	COPPER GASKET DIN7603-10X14X1	2

108171390 / C108171390

\* NEW PART

X AS REQUIRED

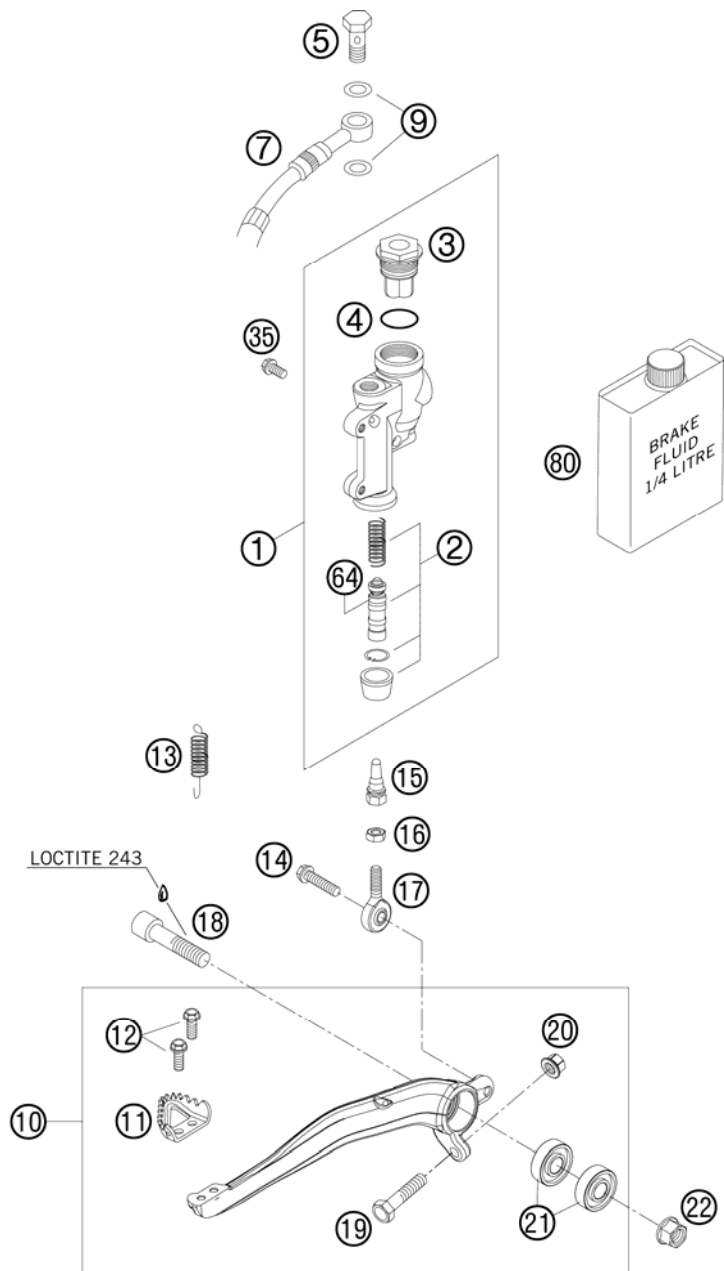

FIG	PART NUMBER	DESCRIPTION	QTY
1	54813060100	REAR BRAKE CYLINDER CPL. 2004	1
2	54813061200	REPAIR KIT PISTON 13MM 06	1
3	54813062100	REAR BRAKE CYL. COVER CPL. 04	1
4	54813063000	FOOT-BRAKE CYL. GASKET SX 03	1
5	54813020200	% BANJO SCREW 08	1
7	54813070000	BRAKE HOSE REAR 655MM 03	1
9	0603100141	COPPER GASKET DIN7603-10X14X1	2
10	77213050044	FOOT BRAKE LEVER CPL.	1
11	54813051000	STEP PLATE FOR BRAKE LEVER	1
12	0025050126	HH COLLAR SCREW M5X12 TX30	2
13	54603062000	RETURN SPRING FOR BRAKE LEVER	1
14	0025060206S	HH COLLAR SCREW M6X20 TX30	1
15	54813056000	PUSH ROD L=28MM 03	1
16	0985060003	SELF LOCK. NUT DIN0985-M 6	1
17	54813055000	SWIVEL HEAD KA6 03	1
18	0032100406S	AH-COLLAR SCREW M10X40 ISA45	1
19	59001037000	SPECIAL SCREW M8X26 WS=10	1
20	46030045000	COLLAR NUT M8 WS=10	1
21	0625060002	BALL BEARING SKF 6000-2RS1	2
22	54630044000	COLLAR NUT M10 WS=13	1
35	0025060126	HH COLLAR SCREW M6X12 TX30	2
64	54813064200	BELLOWS FOR REPAIR KIT 06	1
80	00062030000	BRAKE FLUID DOT5.1 0,25L	1

085031330 / C127741330

\* NEW PART

X AS REQUIRED

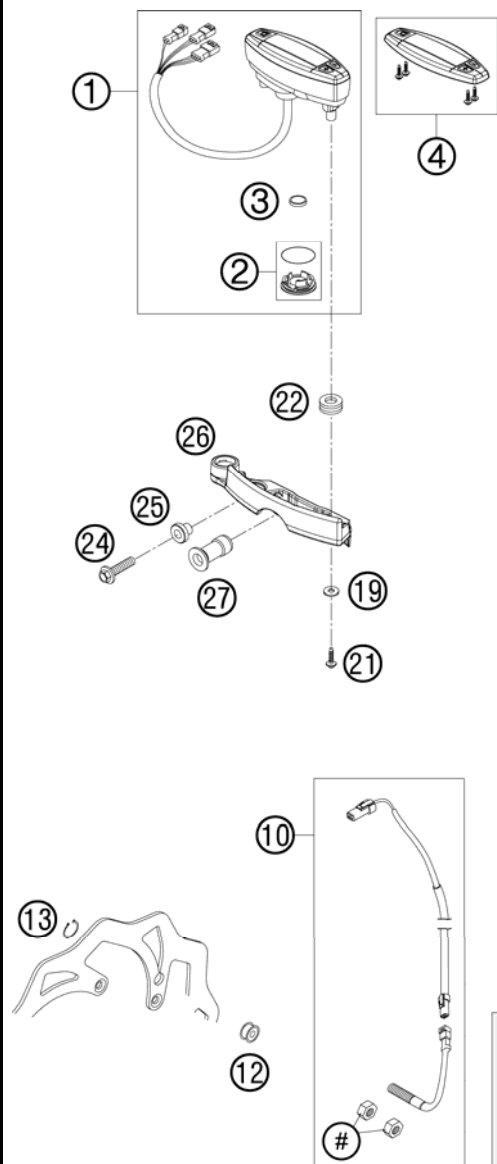

FIG	PART NUMBER	DESCRIPTION	QTY
1	54814069100	SPEEDOMETER MPH F. 21" 2005 REPROGRAMMABLE: MPH - KM/H	1
2	54814069010	BATTERY COVER F. SPEEDOM. 2005	1
3	58314068000	BATTERY F. SPEEDOM. M.A.E. 02	1
4	54814069020	SPEEDOMETER TOP PART 05	1
10	54814068100	CABLE FOR DIGITAL SPEEDOM. 06	1
11	55011022100	CLAMP D=6/8MM, BLACK	3
12	54814069050	MAGNET FOR DIGITAL SPEEDOM. 03	1
13	0471009104	CIRCLIP DIN0471- 9X1 INOX	1
19	0021050003	WASHER DIN9021-A 5,3	2
21	0081050121	SCREW FOR PLASTIC K50X12 T20	2
22	58214069051	RUBBER GROMMET 16X10,8X3 02	2
24	0024060206	HH COLLAR SCREW M6X20 TX30	2
25	59030060050	BUSHING F. SPROCKET COVER RAC.	2
26	54814060100	SPEEDOMETER BRACKET XC-W 08	1
27	54814060051	SPACER TUBE SPEEDOM. XC-W 08	1
42	54813026000	CABLE SUPPORT 10/6MM 06	2

095231430 / C095231430

\* NEW PART

X AS REQUIRED

①  
OHNE ABBILDUNG  
WITHOUT ILLUSTRATION

①  
TECHNISCHE DOKUMENTATION  
TECHNICAL DOCUMENTATION  
DOCUMENTACION TECNICA  
DOCUMENTATION TECHNIQUE  
NOTE TECNICHE

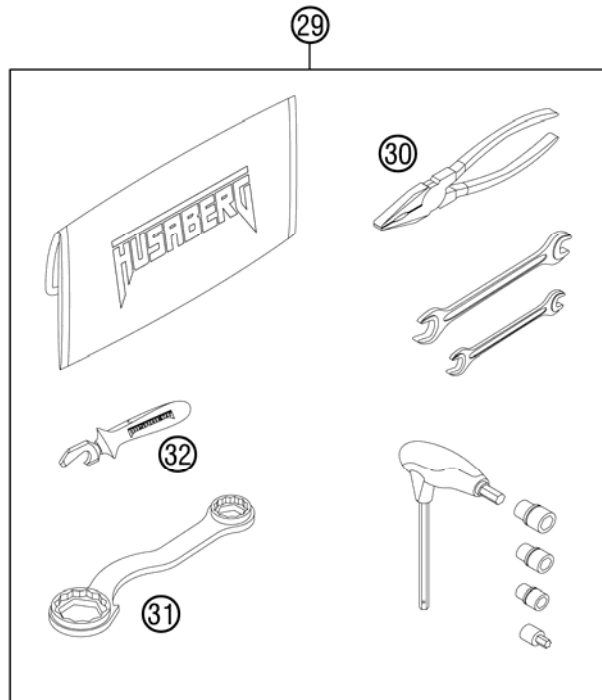
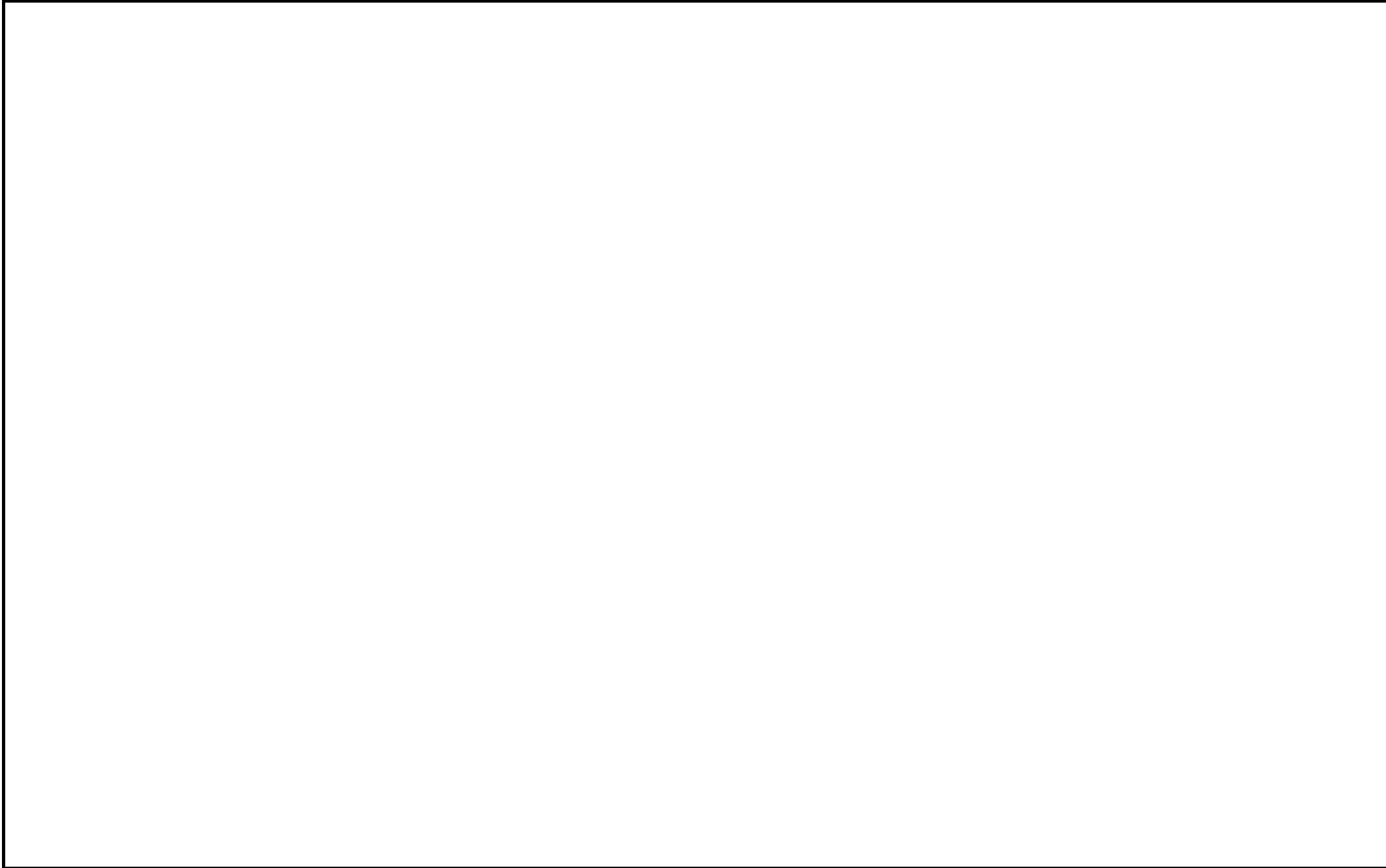

FIG	PART NUMBER	DESCRIPTION	QTY
0	00063004202	PRINT LABEL 60X51 MM	2
0	50308009050	SCREW FEND.BRACE M8X9 WS=17	1
0	50308009051	NUT FENDER BRACE M8 WS=17	1
0	51539974000	MAP SWITCH	1
0	55103190000	SKID PLATE PLASTIC	1
0	77303094100	PLASTIC FRAME PROTECTION SET	1
0	77308010099	MOUNTING KIT FRONT FENDER	1
0	77311053000	BATTERY 12V 3AH YTX4L-BS	1
0	78003040033	FOOTREST L/S + R/S CPL. 09	1
0	7810297900028	HANDGUARDS CPL.LE+RI WHITE 12	1
0	81202002144	BAR PAD CPL.	1
0	8120801000068C	FRONT FENDER BLUE 2012	1
0	81212002000	BAG HUSABERG	1
0	H38090110	HUSABERG BALLPOINT PEN	1
1	3802030EN	OWN. MAN. TE 125-300 2012	1
29	81229599000	TOOL KIT	1
30	53012028200	GRIP ORANGE B&F	1
31	50329080100	WRENCH SW=17/21/27/32 B&F	1
32	81229071000	OPENER HUSABERG	1

118122001 / C125512003

\* NEW PART

X AS REQUIRED







KTM-Sportmotorcycle AG  
A-5230 Mattighofen  
[www.ktm.at](http://www.ktm.at)

KTM Group Partner



3CF2375L9EN



Art.Nr.: 3CF2375L9EN 10/2011